

# E4-WM5-Y686A00 MOUNTING INSTRUCTION



## IMPORTANT! READ THIS FIRST!

Installation of shock absorbers or other suspension components requires special tools and expert knowledge. Accordingly, installation of all BILSTEIN products must be performed by a professional automotive suspension technician.

When replacing other brands, BILSTEIN shock absorbers or other suspension components should always be installed as a set. All BILSTEIN products must only be used for the specific, intended application as indicated in the application guide. **Any use of any BILSTEIN product other than for its intended use may result in serious bodily injury or death.**

Always use a chassis hoist for the installation of BILSTEIN products and make certain that the raised vehicle is securely attached to the hoist and/or supported to prevent the vehicle from slipping, falling, or moving during the installation process.

**If you install any BILSTEIN product without the necessary special tools, expertise, and chassis hoist, you may subject yourself to the risk of serious bodily injury or death.**

BILSTEIN shock absorbers are gas-filled and are highly pressurized.

- Never place any BILSTEIN shock absorbers in a vise or use a clamp on any BILSTEIN shock absorber.
- Never apply heat near any BILSTEIN shock absorber.
- Never attempt to open or repair any BILSTEIN product, in order to prevent **serious bodily injury or death**.

Any attempt to misuse, misapply, modify, or tamper with any BILSTEIN suspension product voids any warranty and **may result in serious bodily injury or death**.

While installing any BILSTEIN product:

- Do not use impact tools for loosening or tightening fasteners, because this may destroy the screw threads.
- Self-locking fasteners must only be used **once!**
- Reuse original equipment components only if they are in good condition, otherwise replace them with new components.
- Never remove the slight film of oil on the shock absorber piston rod and seal.
- All mounting fasteners for shock absorbers and other suspension components must be securely tightened before tension is placed on the suspension system, unless otherwise specified in the manufacturer's service manual or in this instruction.

After installing any BILSTEIN product:

- The suspension caster and camber must be checked and/or adjusted to comply with the vehicle manufacturer's specifications.
- The (load dependent) brake compensator and the anti-lock brake system must be checked and/or reset to comply with the vehicle manufacturer's specifications.
- The headlight aim must be checked and adjusted. Or, if applicable, adaptive headlights must be checked and recalibrated to comply with the vehicle manufacturer's specifications.
- If applicable, any/all Advanced Driver Assistance Systems (ADAS) must be checked and recalibrated to comply with the vehicle manufacturer's specifications.

### **CAUTION for COILOVER TYPE SUSPENSIONS!!!**

**If disassembling a coilover type suspension, refer to the vehicle manufacturer's service manual for proper procedures. The coil spring is preloaded and must be compressed with a spring compressor to release load before the upper mount is disassembled. Failure to follow the vehicle manufacturer's procedures may cause serious injury or death, and may damage the vehicle.**

### **IMPORTANT!!!**

**This BILSTEIN product may or may not be compatible with non-BILSTEIN aftermarket products and/or vehicle modifications. It is the responsibility of the professional automotive suspension technician performing the installation to identify any non-OEM components and/or modifications on the vehicle that may interact with the suspension system. These must be evaluated for any potential physical static or dynamic interference with and/or effect on the function of this BILSTEIN product.**

# E4-WM5-Y686A00 MOUNTING INSTRUCTION



## IMPORTANT:

### FOR B8 5100, PLACE CIRCLIP IN APPROPRIATE GROOVE TO ADJUST RIDE HEIGHT.

Use appropriate tools to move the circlip. Ensure that the circlip is fully seated in the groove after moving it (you should be able to rotate it manually in the groove). Install the spring seat in the direction shown only. The circlip must fit completely in the groove inside spring seat (A). **Improper installation will cause permanent damage to the shock!**

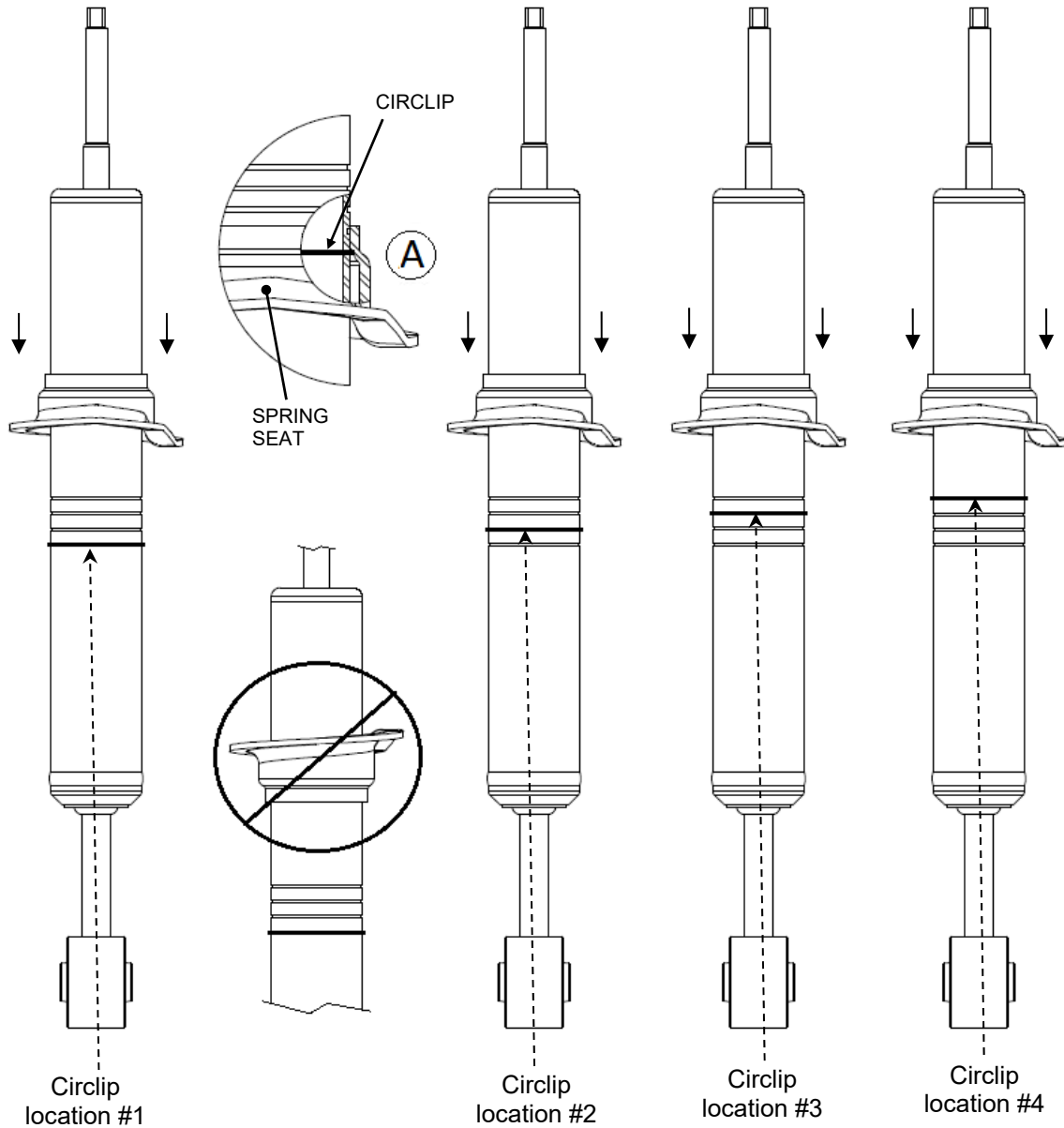

Circlip location	Typical Lift Height**
#4	2.5"
#3	1.75"
#2	0.85"
#1	stock

# E4-WM5-Y686A00 MOUNTING INSTRUCTION



\*\* Ride heights indicated are typical. Actual ride height is influenced by which factory suspension the vehicle is equipped with and its condition; optional equipment and accessories on your vehicle, and other vehicle modifications such as replacement coil springs, wheel and tire combinations, etc. Modifying/lifting the suspension to your vehicle may raise its center of gravity and may make it more susceptible to loss of control and/or rollover, which may result in death or serious injury. We strongly recommend that you offset the loss of rollover resistance as much as possible by increasing tire track width, and that you equip the vehicle with a functional roll bar and cage system. Wear seat belts and shoulder harnesses at all times, and avoid situations where a side rollover may occur.

## Instructions for disassembly of OE shock absorber module:

- A. Remove the existing shock and spring unit from the vehicle following all procedures in the vehicle manufacturer's service manual.
- B. Note the clocking of the lower mount bushing relative to the studs on the upper mount (important for reassembly).
- C. Also note the clocking of the suspension spring relative to the upper mount. It is recommended to mark the upper mount (on the metallic area) as shown in Figure 1 to indicate the position of the end of the top coil (important for reassembly).



- D. Using an appropriate spring compressor, compress the spring until it can be rotated freely by hand. Then, disassemble the shock and spring unit.

# E4-WM5-Y686A00 MOUNTING INSTRUCTION



## Instructions for assembly of Bilstein shock absorber module:

- E. Temporarily remove the dust boot from the new Bilstein shock.
- F. Install the supplied spring seat on to the new Bilstein shock such that the groove inside the spring seat fits over the circlip on the shock body as shown on page 2. Install the spring seat in the direction shown only. The circlip must fit completely in the groove inside the spring seat (see detail view A on page 2). Improper installation will cause permanent damage to the shock.
- G. Reinstall the new dust boot back on to the new Bilstein shock.
- H. Install the supplied lower washer (concave side up) onto the stem of the rod as shown. Ensure that the lower washer is oriented correctly (see Figure 2).
- I. Using an appropriate spring compressor, compress the OE spring and assemble it with the new Bilstein shock. Align the bottom coil of the spring with the ramp on the spring seat. Refer to Figure 2 for the order of the remaining components.
- J. Install the OE upper mount over the threaded stem on the new Bilstein shock and on top of the spring. **Note that GX470 owners must purchase Toyota Upper Mount Assy. 48609-60100** (this part number is valid as of 3/26/20). Rotate the upper mount so that the end of the top coil is aligned with the mark on the upper mount made in step C. Rotate the shock so that the lower mount is aligned with the upper mount studs as noted in step B.
- K. Install the supplied upper bushing and supplied upper washer (concave side down) as shown. Ensure that the upper washer is oriented correctly (see Figure 2).
- L. Install the provided new locknut and tighten to 27 N·m (20 lb·ft). Use a 7mm wrench to keep the piston rod from rotating while torquing the lock nut.  
**\*\*\*\*DO NOT USE AN IMPACT WRENCH TO TIGHTEN THE LOCK NUT! \*\*\*\***
- M. Release the spring compressor while ensuring that the ends of the spring remain aligned with the spring seat and upper mount.
- N. Install the assembly on to the vehicle and tighten all fasteners to vehicle manufacturer's specifications.
- O. Check wheel alignment. If necessary, adjust to the vehicle manufacturer's specifications. This completes the installation.

# E4-WM5-Y686A00 MOUNTING INSTRUCTION

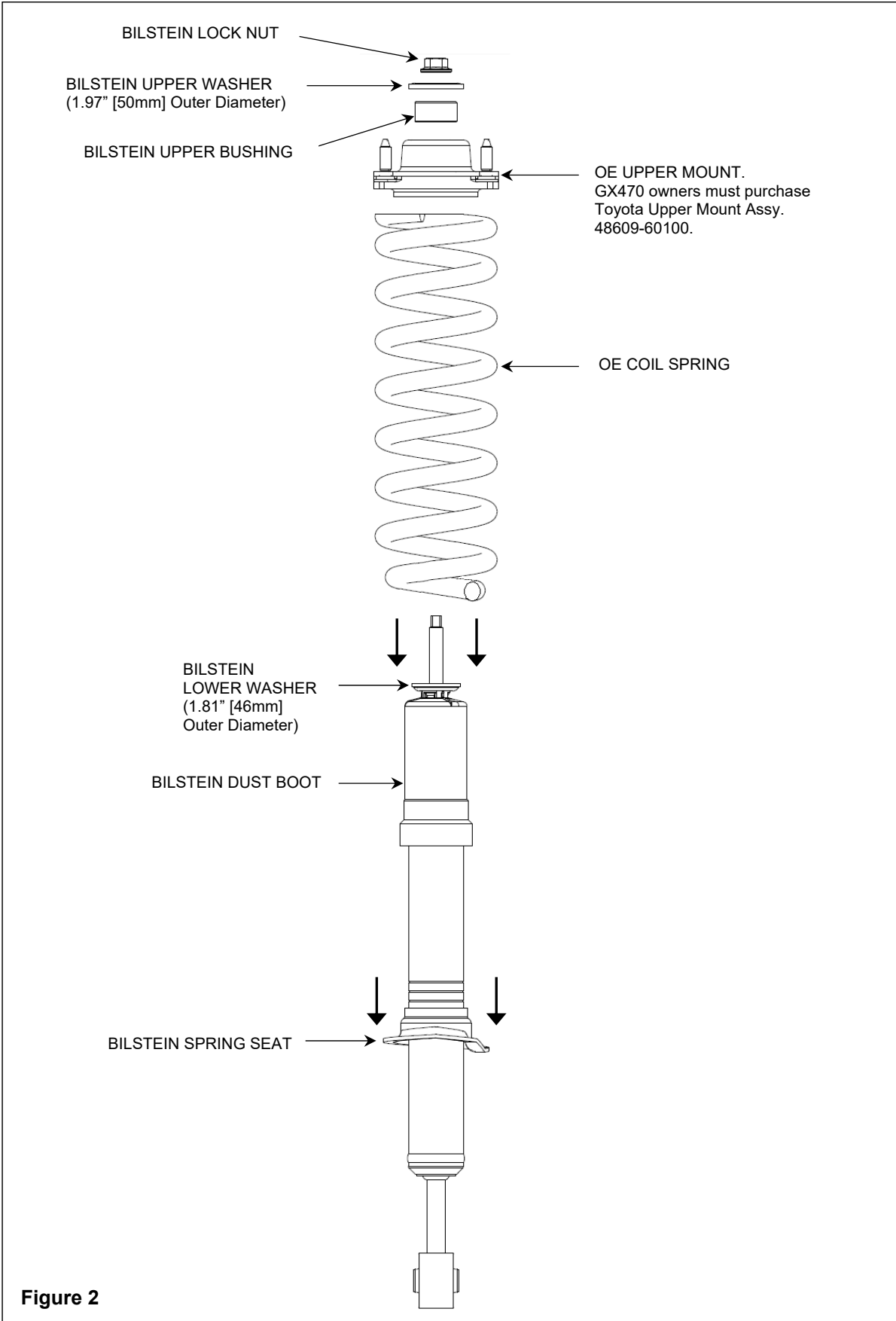

Figure 2