

DINAN

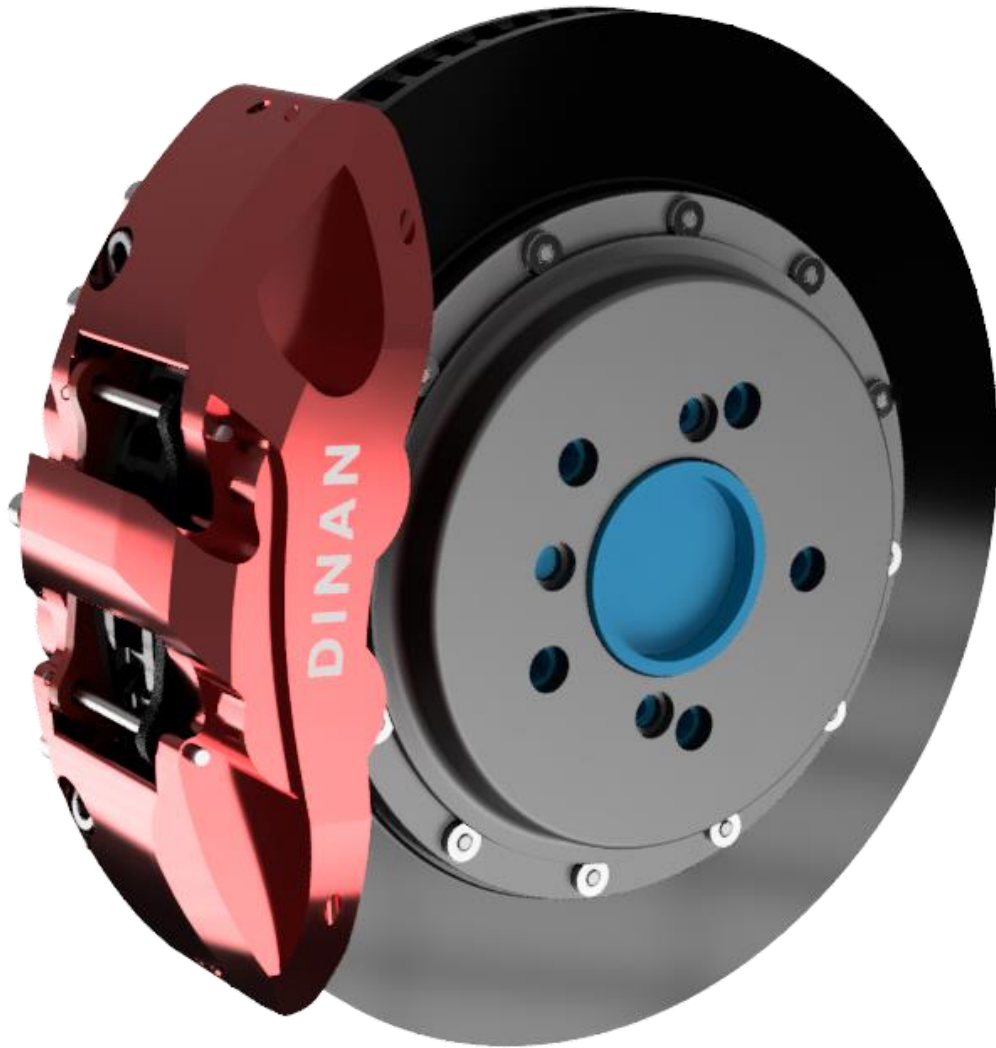

**Installation Instructions (Rear)
BMW 3-Series F2X / F3X (excl M models)**

D290-1006-G & D290-1006-R

Vehicle assembly diagram

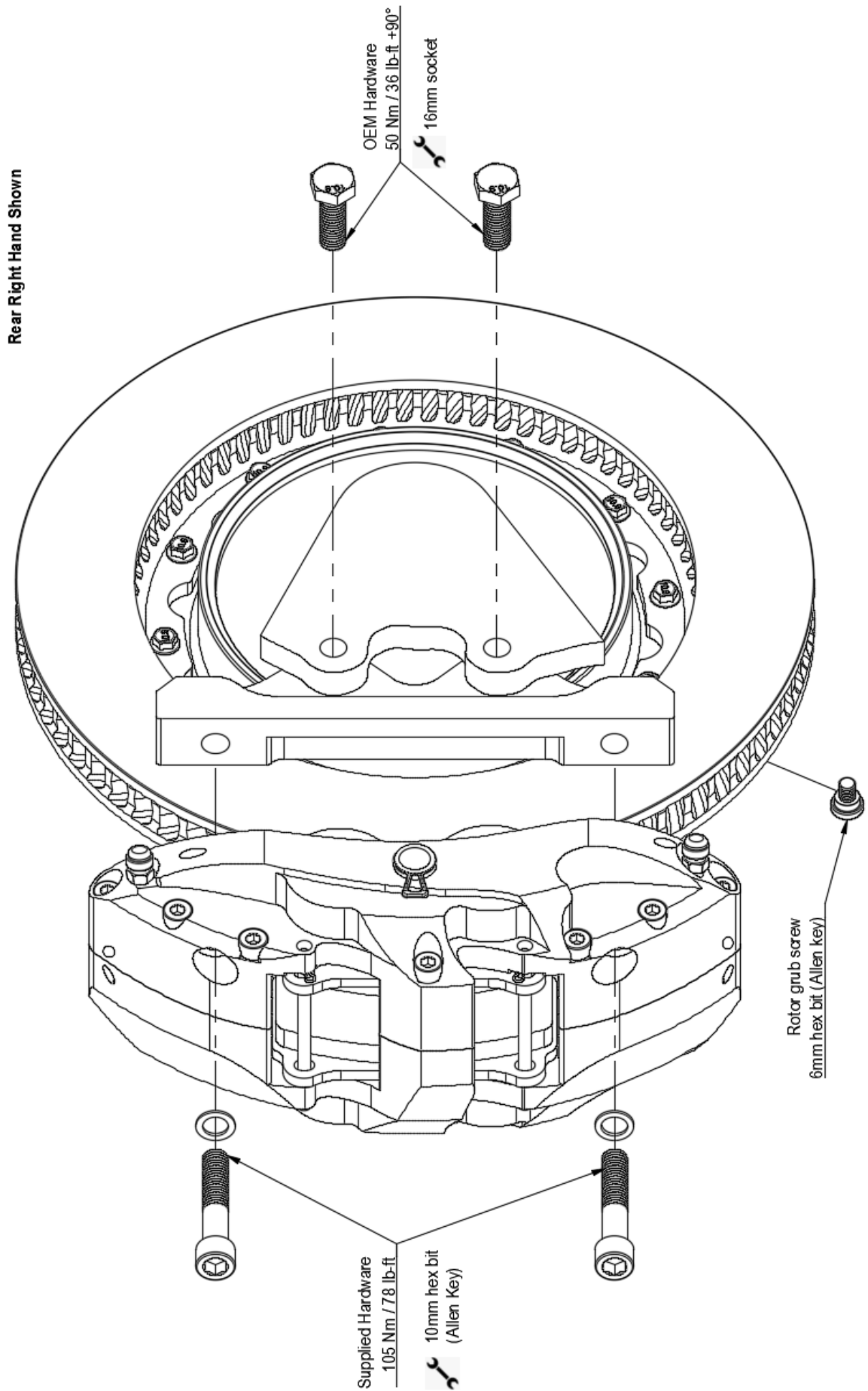

All rights reserved. No part of this document may be reproduced in any form or by any electronic or mechanical means, including information storage and retrieval systems, without permission in writing from the author. Copyright © C. Murphy / DINAN.

The author of this document cannot accept any responsibility for any proceedings or prosecutions brought or instituted against any person or body as a result of any use or misuse of any of the procedures described herein, or any loss, injury or damage caused thereby. The procedures described in this document are to be used in accordance with national traffic laws. Your safety depends on your own judgment while driving. If you misinterpret a procedure discussed in this document or drive irresponsibly, you could be seriously injured or killed as a result.

Before starting:

If you have not already done so, ensure your wheels will clear the calipers in your big brake kit. Please refer to the “wheel fitment template” at the end of these instructions.

Your kit should include the following:

- 2 x S4R 4-piston billet calipers
- 1 x set high-performance pads pre-loaded into the calipers
- 2 x aircraft grade aluminium mounting brackets
- 2 x 2-piece floating rotor assemblies, marked ‘left’ and ‘right’
- 2 x steel braided hoses including:
 - 2 x M10 banjo bolts
 - 4 x copper washers
- 4 x high tensile radial mounting bolts & washers
- 2 x rubber end caps

Removal of standard rear brake components

- After securing the vehicle carefully on jack stands – remove the rear wheels.
- Release the park brake.
- Leave the cap tightly on the master cylinder reservoir. Loosening the cap will cause more brake fluid to drip/leak when removing the standard brake components.
- Place a drip tray directly below the area where the original rubber brake hose and steel ‘hard’ brake line from the chassis meet.



WARNING:

Brake fluid will damage any painted surface. We recommend keeping some warm, soapy water on hand during the entire installation process. Use this water to immediately clean spilled brake fluid from any painted surface.

- You will find two additional rubber caps supplied in your Big Brake Kit. These are to be placed over the end of the steel ‘hard’ brake lines, once the rubber brake hoses have been removed, in order to stop the brake fluid from dripping/running out during the installation process.
- Loosen the hard-line tube-nut that screws into the rubber brake hose on the inboard side closest to the chassis.
- Place one of the rubber caps over the end of the steel ‘hard’ brake line immediately to limit brake fluid loss.
- Remove the stock caliper mounting bolts that fasten the caliper to the knuckle.

- Keep the stock caliper mounting bolts, which will be re-used to attach the DINAN caliper mounting bracket to the knuckle.
- Remove the stock caliper with the rubber brake hose still attached. Be aware that some fluid may leak from the open end of the rubber brake hose.
- Remove the grub screw retaining the stock brake rotor to the hub, then remove the rotor from the hub. If the rotor is stuck to the hub, use a hammer around the rotor hat outboard face to 'shock' it loose. Keep one wheel nut in place to 'catch' the rotor when it comes loose.
- Leave the pad wear sensor plug connected and pull the sensor from the original pads. Cut off the sensor head, strip the wires back carefully and twist them together. Tape up the wires and zip-tie them in a safe spot.

Fitting DINAN Big Brake Kit components

DINAN big brake kit components are labeled "Left" and "Right". In all instances, it refers to the left or right of the vehicle when seated in the vehicle.

Mounting brackets

- It may require minor trimming of the OE dust/splash shield to fit the brackets. Use a metal shears to trim, and file the edges smooth.
- Clean the caliper mounting lugs on the knuckle using brake cleaner or solvent.
- Ensure that the stock caliper mounting bolts are clean and in good condition. Use brake cleaner or a solvent to clean the bolts if necessary. Apply a small amount of thread-locker to the threads of the stock caliper mounting bolts. **RACE TEAMS:** We recommend that you torque check your axial mount bolts after every event. In this instance, do not use any thread locker on mounting bolts.
- Use the stock caliper mounting bolts to attach the DINAN caliper mounting bracket to the knuckle. See Vehicle assembly diagram for mounting bracket orientation and tightening torque.

Rotors



IMPORTANT:

There may be considerable rust/corrosion buildup that has formed on the mounting surface of the hub. It is essential that you thoroughly clean the mounting surface of the hub with a wire brush, Scotch bright or emery paper followed by a brake cleaner or solvent. The mounting surface of the hub must be perfectly clean. Failure to do this can lead to excessive run-out on your new brake rotors and result in the onset of brake judder.

Do not ignore this important step!

- Once clean – check the hub surface for any burrs or imperfections. Minor burrs may be removed using a fine-tooth file. Work carefully.
- If possible, measure the runout of the newly cleaned hubs using a dial gauge. The runout on each hub should be in the 0.01mm – 0.02mm (0.0004 – 0.0008in) range. Do not fit your rotors to a hub with excessive runout, as this will result in brake vibration and damage to the new rotors.
- Wheel bearings must be in good condition and correctly torqued.

- The new rotor features a handbrake 'drum' built into the aluminum hat. If necessary, adjust park brake shoes down to allow fitment of the new rotor hat over the park brake shoes. This must be done in accordance with the OE BMW instructions (summarized further in this document).
- Test fit the new rotor by hand to ensure that the rotor sits flat against the hub face with a minimum of 3mm (0.1in) clearance between the rotor and dust/splash shield. If necessary, the shield must be trimmed or carefully bent away from the rotor to achieve the 3mm (0.1in) clearance.



IMPORTANT:

Your new DINAN 2-piece rotors each have 72 directional cooling vanes. Be sure to fit the correct rotor to each side of the car. Reversing the rotor direction will substantially reduce the cooling efficiency of the rotors. The packet in which each rotor is sealed is clearly marked "Left" or "Right" side. The internal cooling vanes should "lean" to the rear of the car on the top side of the rotor (see below).

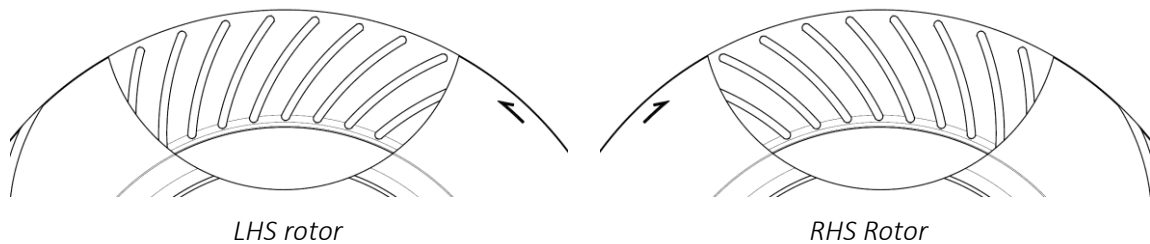

- Fit the rotor to the hub and use the wheel nuts (and spacers/washers if necessary) to hold it in place without the wheel. Tighten using moderate torque. Now measure the runout on the rotor friction surface, approximately 2cm (1in) from the edge of the rotor, using a dial gauge. The runout should be in the 0.05mm – 0.07mm (0.002 – 0.0027in) range and must not exceed 0.08mm (0.003in).
- Readjusting the park brake to the new rotors is summarized further in this document.

Calipers and brake lines

- DINAN uses stainless steel Heli-coil™ inserts for the radial mountings in the caliper brackets. Do not use any thread locker / Loctite on caliper radial mounting bolts. Use a small amount of thread lubricant (such as *ARP Fastener Assembly Lubricant*) on the bolt threads. **RACE TEAMS:** We recommend that you torque check your radial mount bolts after every event.
- Slide the caliper and pads over the rotor and using the M12 mounting bolts and washers supplied, bolt the caliper down onto the mounting bracket. The washers must be fitted underneath the bolt heads, not underneath the caliper. Torque the radial mounting bolts to 105Nm (77 lb-ft).



IMPORTANT:

Ensure that the caliper is perfectly centered over the rotor and that no part of the caliper is fouling the rotor at all.

With the caliper mounted to the bracket, measure rotor to caliper clearance on either side (A and B on the next page). The difference between the two dimensions must not exceed 1.0mm (0.04in) either at the top or bottom of the caliper.

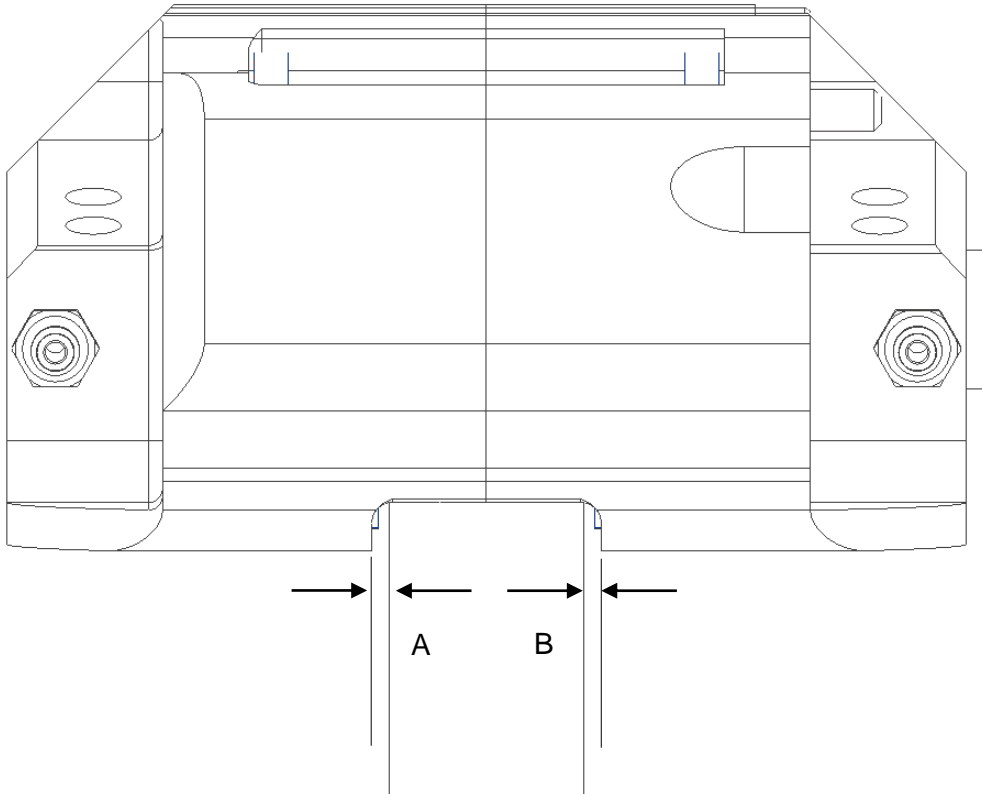

Install the DINAN stainless steel braided brake hose with the banjo fitting at the caliper end and the female fitting at the steel hard-line. After removing the red plastic tab from the caliper fluid inlet, install the banjo bolt into the caliper with a copper washer on each side of the banjo fitting as per the image below.

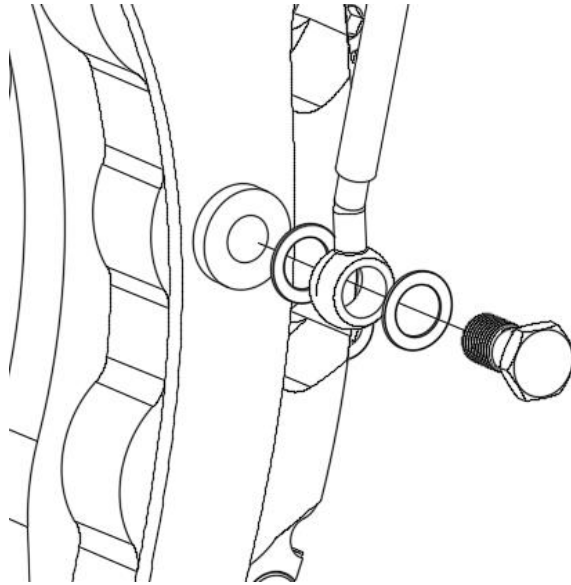

WARNING:

Failure to use a ductile washer on either side of the banjo fitting can result in a leak and loss of brake system pressure under braking.

- Align the neck of the banjo fitting in the direction of the brake hose locating bracket on the shock strut.
- Torque the banjo bolt to 20Nm (15 lb-ft).
- If applicable, slide the rubber grommet on the brake hose into the locating bracket on the strut. The hose should be free to move within the grommet.
- If applicable, secure the female fitting of the new hose to the locating bracket on the chassis using the stock spring or clip. If this is not possible then use a cable tie to secure the female fitting to the locating bracket.
- Remove the rubber cap from the end of the steel (hard) brake line and immediately screw the tube nut on the hard-line into the female fitting on the flexible brake hose. Ensure that the fittings are tight but do not over-tighten them.



IMPORTANT:

Once hoses are fitted, carefully check that neither the caliper mounting bracket or the brake hose are binding or fouling in any way with the axle at full droop. If necessary, make adjustments by re-clocking the banjo fitting in order to re-direct the brake hose. Re-tighten the banjo bolt to 20Nm (15 lb-ft) once done.

The process described above is the same for both sides of the car. Complete the installation of the DINAN components on both sides of the car before bleeding the brakes.

All rights reserved. No part of this document may be reproduced in any form or by any electronic or mechanical means, including information storage and retrieval systems, without permission in writing from the author. Copyright © C. Murphy / DINAN.

The author of this document cannot accept any responsibility for any proceedings or prosecutions brought or instituted against any person or body as a result of any use or misuse of any of the procedures described herein, or any loss, injury or damage caused thereby. The procedures described in this document are to be used in accordance with national traffic laws. Your safety depends on your own judgment while driving. If you misinterpret a procedure discussed in this document or drive irresponsibly, you could be seriously injured or killed as a result.

Bleeding the brakes

- The S4R caliper features two bleed nipples both mounted to the inboard side of the caliper. The internal fluid channels in the S4R caliper are angled to ensure all air can be expelled during the bleeding process. It is recommended to use the top bleed nipple during initial bleeding of the caliper. The bottom bleed nipple can be cracked open slightly before final bleeding to ensure any air trapped in the lower channel is expelled. Final bleeding should however only be done through the top bleed nipple.
- The new brake hoses and calipers will have to fill with fluid during the bleeding process. This will quickly drain the master cylinder reservoir. Do not allow the master cylinder reservoir to run dry and draw air into the system. Doing so may require the brake system to be serviced by a certified brake technician. You will need to top up the master cylinder reservoir regularly with new brake fluid while bleeding.
- Use a clear bleed tube and bleed bottle when bleeding. The clear tube should fit tightly onto the heads of the bleed screws in order to avoid brake fluid spilling onto the calipers and brake pads. It is very important to avoid contaminating the brake pads with brake fluid as this will reduce brake efficiency. Use an 11mm box-end wrench to aid with bleeding (see below).

Pass the bleeder pipe through the box-end of the wrench and onto the bleed nipple



- Use a brake fluid that is compatible with the seals in your brake system. DINAN recommends Glycol based brake fluids that meet DOT 4 specifications or higher. Do not use Silicone based brake fluids with DINAN calipers. For recommendations on specialised high-temperature or competition brake fluids, please contact DINAN.
- The sequence for bleeding the brakes should be:
 1. Caliper furthest from master cylinder
 2. Caliper closest to master cylinder
- With the ignition and engine OFF, start by opening a bleed nipple slightly (quarter to half a turn is usually enough) and have a second person pump the brake pedal slowly a number of times to expel air from the system and start filling the new brake lines and calipers with fluid. The person pumping the brake pedal should not depress it to its furthest extent, preferably only half way – this is particularly important on vehicles with higher mileage and more wear in the master cylinder. Pump the brake pedal until clean fluid runs into the bleed bottle. Close the bleed nipple only while the brake pedal is depressed. **NB: DO NOT LET THE RESERVOIR RUN DRY DURING THIS STAGE. FILL IT REGULARLY.** Repeat this process on both calipers.
- Next, return to the first bleed nipple and attach the bleed bottle again. Get the second person to pump the brake pedal five times in rapid succession with the bleed nipple closed. Open the bleed nipple very slightly while they keep pressure on the pedal to release any trapped air. Continue until no more escaping air bubbles are visible. **NB: DO NOT LET THE RESERVOIR RUN DRY DURING THIS STAGE. FILL IT REGULARLY.** Repeat this process on both calipers, and both bleed nipples.
- Tighten all bleed screws to a torque of 20-25Nm (12.5 – 18.5lb-ft).
- Once the bleeding is complete we recommend you soak up excess brake fluid remaining in the bleed screw. Roll a piece of tissue paper into a thin strip and insert into the bleed screw to soak up the fluid. Repeat this procedure for each of the four bleed screws until the tissue remains dry and is soaking up no more brake fluid.



- Place the rubber bleed screw caps provided onto each bleed screw.
- Get a helper to apply a constant pressure to the brake pedal while you check all connections, including bleed screws and both end of each brake hose for leaks. Tighten if necessary.
- MAINTENACE: DINAN recommends flushing the brake system with new brake fluid every 24 months.



IMPORTANT – Service Bleed:

On a dry bleed (first time bleed on a new caliper) some air may be trapped in the very tight tolerances between the caliper pistons and bores, resulting in a slightly spongy brake pedal. The vibration and suspension movement experienced under normal driving conditions will cause these small air pockets to rise to the top of the calipers near the bleed screws for easy bleeding. We recommend driving the vehicle for ± 50 km (30 miles) before doing a final service bleed*. This will result in the best possible pedal feel. If you are a workshop and have to deliver the vehicle same-day, we suggest driving out and performing at least 20 x stops from low speeds before returning to the workshop for a 'service bleed'. (This does not apply in cases where there is excessive pedal travel after initial bleeding, in which case the system should be checked for visible leaks, but only in cases where the pedal feel is not quite optimal).

* Service Bleed

1. Have a 2nd person pump the brake pedal rapidly and then holding pressure on it.
2. Crack the bleed nipple only a fraction (1/4 turn) to allow fluid/air out before tightening again.
3. Repeat for all bleed nipples until no more bubbles are expelled.
4. Pressure must only be released on the pedal once the bleed nipple is closed.

Resetting the park brake

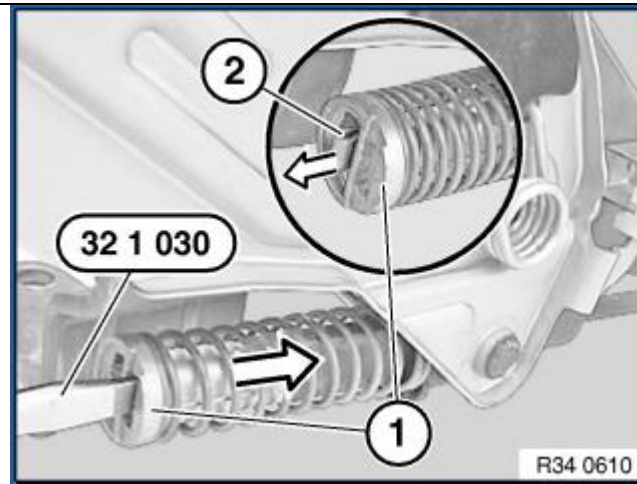

To adjust the park brake shoes, tension needs to be removed from the cable.

Unclip the park brake handle gaiter using a suitable trim tool to expose the park brake spring underneath the handle.

Push the park brake spring (1) back with a suitable screw driver until the retaining hook (2) engages.

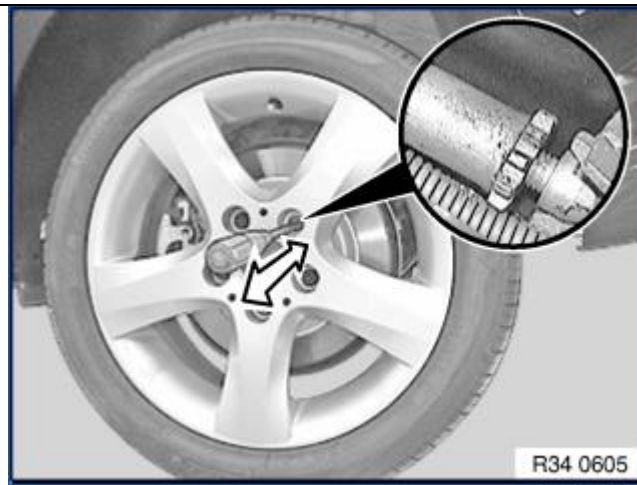

The next step can be done with wheel on or off. If the wheel is back on, one wheel lug nut should be removed to provide access to the park brake adjuster.

Find the park brake adjusting screw for the park brake shoes, and using a flat screw driver, turn the screw until the wheel/rotor can no longer rotate (the adjuster screw should be rotated clockwise if looking at it from the rear of the car).

Then back off the adjusting screw a total of 8 clicks/notches to provide correct clearance between shoes and drum.

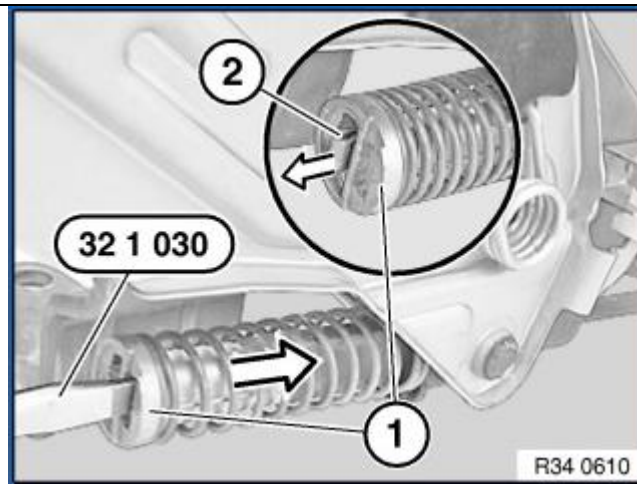

Now release the park brake spring by levering out the restraining hook (2) with a hook or small screw driver.

Replace the handbrake lever gaiter.

The vehicle should hold against the park brake ideally with 3-5 clicks of the handbrake lever.



WARNING:

The rear rotors feature an aluminum hat with a built-in drum for the park brake.

The handbrake must thus only be used in a *STATIC* application with this kit. It is not designed for initiating a drift or for using the handbrake while the vehicle is in motion (unless for an emergency)

All rights reserved. No part of this document may be reproduced in any form or by any electronic or mechanical means, including information storage and retrieval systems, without permission in writing from the author. Copyright © C. Murphy / DINAN.

The author of this document cannot accept any responsibility for any proceedings or prosecutions brought or instituted against any person or body as a result of any use or misuse of any of the procedures described herein, or any loss, injury or damage caused thereby. The procedures described in this document are to be used in accordance with national traffic laws. Your safety depends on your own judgment while driving. If you misinterpret a procedure discussed in this document or drive irresponsibly, you could be seriously injured or killed as a result.

Re-installing the wheels

It is essential to carefully check wheel / caliper clearance before re-installing the wheels. Of particular importance is wheel spoke clearance to the outboard caliper face! A minimum of 2.5mm (0.1") is required. DINAN cannot possibly check all aftermarket wheels for any specific vehicle. Wheel clearance is the vehicle owner's responsibility. Some wheels may require spacers in order to clear the calipers.

Some wheels are balanced using adhesive backed lead on the inboard side of the wheel. If the weights have been placed on the outboard edge (closest to the wheel spokes) they may interfere with the caliper as the wheel rotates. If this is the case, note the position and weight and place a new weight slightly further inboard on the wheel in order to clear the caliper. Alternatively, have your wheels re-balanced by a certified technician, once you have explained the situation to him clearly.

- Before reinstalling the wheels, ensure that sufficient length of wheel stud is available for proper thread engagement with the wheel nuts (a good rule of thumb is that available stud length should be $\pm 1.5 \times$ diameter of the stud). If not, longer wheel studs would be required.
- Re-install the wheels and torque the wheel nuts to the manufacturers recommended specifications.
- Rotate the wheels while the car is still on the jack stands and check one last time to ensure that the wheels and wheel spokes clear the calipers by at least 2.5mm (0.1").
- Lower the vehicle back onto the ground safely.
- Carefully test drive the vehicle at low speed in a safe area to ensure that all brake components are working correctly before continuing on to the bed-in procedures described next.

Bedding-in your new DINAN rotors/pads

- Drive normally for 180 miles to establish proper surface area contact between rotors and pads. Use firm brake pedal pressures during this period but try to avoid stopping from very high speeds. Note: Long open-road trips do not count towards the 180 miles as you are not using your brakes regularly enough.
- After the 180 miles, find a quiet road - drive slowly for a few miles, using the brakes gently to bring them up to a moderate temperature. You are just getting some moderate heat into your rotors so that you do not thermal shock them during the next step.
- Next, while observing potential traffic behind you, perform 8 to 10 relatively hard stops from freeway speeds down to 20mph. (Do not actually bring the vehicle to a complete stop at any stage). Between stops, accelerate back to freeway speeds as quickly as possible. The idea is to put some heat into the rotors.
- After a few stops, you may feel the pads fade (i.e. the friction level will drop off) and a little smoke may be evident from the pads. This is normal. As soon as you feel this happening, or after the 8 to 10 stops you can drive on, using the brakes as little as possible for at least 6 miles in order to allow airflow to cool the rotors.
- Park the car and let the brakes cool completely to ambient temperatures (at least 30 mins). The above procedure should have turned the Blue MTR tab (see overleaf) to light brown. If not, repeat.

The rotors and pads are now ready to use.

All rights reserved. No part of this document may be reproduced in any form or by any electronic or mechanical means, including information storage and retrieval systems, without permission in writing from the author. Copyright © C. Murphy / DINAN.

The author of this document cannot accept any responsibility for any proceedings or prosecutions brought or instituted against any person or body as a result of any use or misuse of any of the procedures described herein, or any loss, injury or damage caused thereby. The procedures described in this document are to be used in accordance with national traffic laws. Your safety depends on your own judgment while driving. If you misinterpret a procedure discussed in this document or drive irresponsibly, you could be seriously injured or killed as a result.

How to get the maximum wear life from your rotors and pads:

- Be sure that you have followed the fitment and bed-in instructions on the flip side of this page.
- Do not run your rotors at temperatures over 630 deg C (1166 F). Doing so will substantially reduce product life. DINAN rotors in this kit features a unique MTR (Maximum Temperature Recording) system. This consists of different levels of thermally sensitive paint that is applied to the outside edge of the rotor. Each of the paints will change color at a specific temperature, hereby providing a permanent record of the maximum temperature reached by the rotor. The paints will change only once, so it is recommended that you gradually build up your driving style after bedding in the rotors and monitor the MTR paints after each driving session. For maximum rotor life, temperatures should be kept under 630 deg C (1166 deg F).

Blue paint - turns Light Brown at 275 deg C (527 deg F).

Green paint - turns White at 460 deg C (860 deg F).

Orange Paint - turns Yellow at 550 deg C (1022 deg F).

Red / Pink paint - turns White at 630 deg C (1166 deg F).

- Ensure that you are running a brake pad compound that is designed to operate in the rotor temperature range that your driving style produces. If you run your brake pads above their recommended maximum operating temperature (MOT) they will start to deposit friction material unevenly on the face of the rotor, leading to the development of rotor thickness variation (DTV) and brake judder.
- Warm up your rotors prior to hard driving. It is best to get some heat into your rotors by driving moderately prior to spirited driving sessions - involving heavy, consecutive braking.
- It is important that you do not park your car with extremely hot rotors. After a spirited driving session you should slow down and use the brake as moderately as possible for about 3-4 km's prior to reaching your destination. This allows rotor temperatures to come down to acceptable level prior to parking the car.
- Nothing stresses brake rotors and pads like heavy, consecutive, robot-to-robot braking. If you are into 'street racing' it is recommended that you limit heavy braking to 3-4 consecutive intersections before driving on and allowing airflow to cool the rotors for a few minutes. Use the brakes only mildly during this cooling period and, if possible, do not bring the vehicle to a complete stop. It is important that you continue moving to allow airflow to cool the rotors.
- Never intentionally wet your rotors when they are hot. Be careful of using drive-through car washes when rotors are hot.
- All DINAN calipers feature temperature recording strips applied to the inboard surface of the calipers. The white 'line' in the centre of the strip will turn dark in dictating the maximum temperature reached by the caliper. For maximum seal life temperatures should be kept below 200 deg C (392 F). Caliper temperatures over 200 deg C (392 F) will lead to reduced seal life. If a caliper reaches 250 deg C (492 F) the seals should be replaced immediately. New seal kits can be ordered directly from DINAN.
- As the DINAN kit is a performance product, and due to the properties of materials used during construction, braking may be associated with elevated levels of noise, vibration and harshness. This is normal and will not impede brake performance or safety.
- **Be very careful when using aggressive wheel cleaners that contain strong acids as it will discolour the caliper and rotor hat finishes.**

Changing pads – S4R caliper

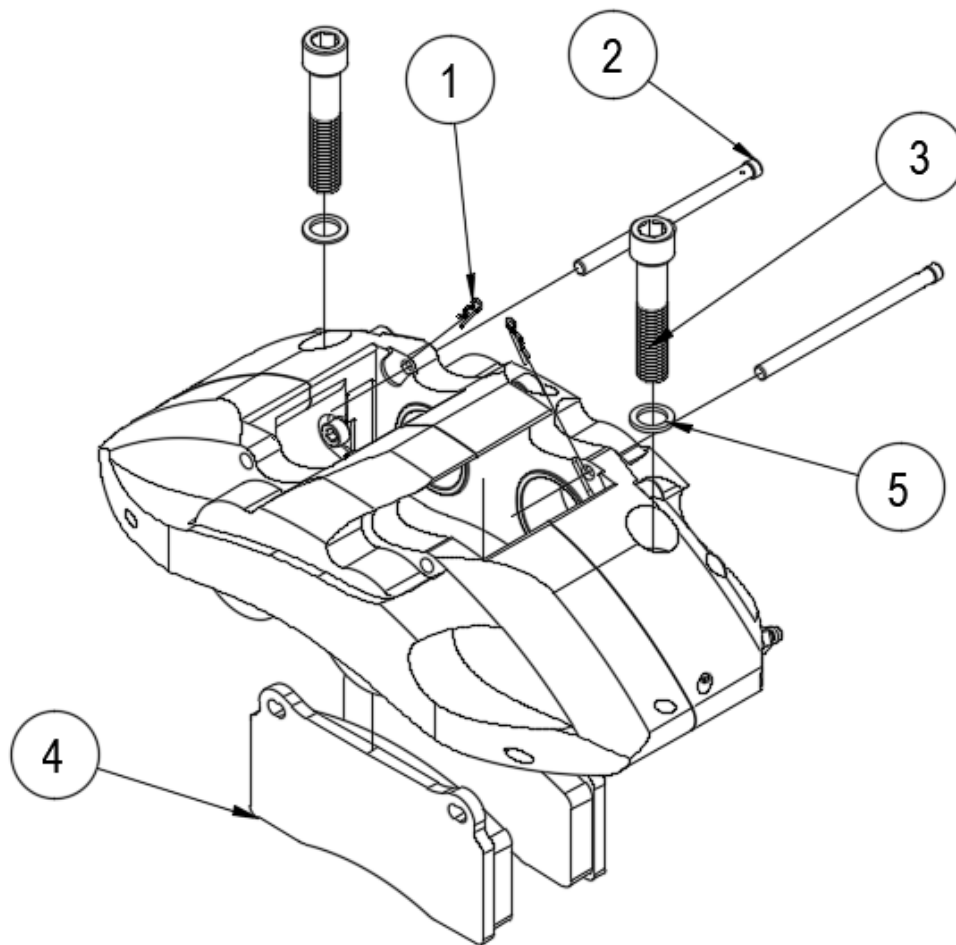

To remove and replace pads on the S4R caliper, follow the steps below:

- 1) Remove the two R-clips (#1) from the pad retaining pins. Use a thin screw driver or hook-and-pick set to prise the R-clips upwards. Be careful not to lose them.
- 2) Push the pad retaining pins (#2) out from the rear of the caliper. They can be knocked out using a 5mm punch and light hammer.
- 3) Remove the caliper by undoing the two radial mounting bolts (#3) using a 10mm hex driver (Allen key), and hang the caliper onto the strut with a zip-tie. Do not disconnect the brake hose and do not let the caliper hang on the brake hose as it may cause damage to the hose.
- 4) Slide the pads (#4) out at the bottom of the caliper.
- 5) Clean around piston walls with brake cleaner before pushing them back into the caliper body.
- 6) Refit your new pads by sliding them up into the caliper. There is some resistance to the pad sliding in, this is the tensioning plate in the caliper and is normal.
- 7) Re-fit the pad retaining pins (#2).
- 8) Fit the caliper back onto the bracket and torque radial mount bolts to 105Nm (77 lb-ft). Ensure the washers (#5) below the radial mount bolts are still present.
- 9) Refit R-clips (#1). **IMPORTANT – do not drive without R-clips fitted.**

Brake pad replacement part numbers

Manufacturer	Part #
FMSI	D810 / D968
Endless Advance	RCP077xxxx
G-Loc	GP968
Ferodo (Street)	FDS1281
Ferodo (Race)	FCP1281x
Hawk Performance	HB193x.715
Pagid (Race)	1287
Centric	308.09680
PFC	7780.xx.18

*In all cases above, "X" is a place holder for the pad manufacturer's friction material compound code.
Contact DINAN for more advice on compound selection if not sure*

WARRANTY:

DINAN (PTY) LTD will guarantee any product manufactured by the company that is found to be faulty in workmanship or materials with 12 months or 12,500 miles use (whichever occurs first).

The warranty does not extend to faults or failure caused by ordinary wear and tear, misuse/abuse, use of the product for any form of motor sport or track-day use, incorrect fitting, use of incorrect or defective associated component parts (e.g. pads), or any cause not relating to a defect in design or manufacturing.

IMPORTANT: All DINAN rotors and calipers feature our MTR (Maximum Temperature Recording) tabs that are applied to the outside diameter of each rotor and the inboard side of each caliper. The above warranty is VOID if any DINAN rotor is run to maximum temperatures in excess of 630 degrees C (1166 F) or any DINAN caliper to run to maximum temperatures in excess of 200 degrees C (392 F).

How to use this template:

1. Print "**Actual size**" (no scaling) with paper size set to Letter Landscape.
2. Glue this page onto a suitable piece of cardboard.
3. Cut along the outline below. *This includes a 0.1" clearance gap required for the brake system to fit under your wheel.*
4. Remove a wheel and lay it face down.
5. Fit the "Wheel Spigot" section into your wheel's center hole.
6. Check that the template cutout clears the wheel surfaces to ensure sufficient clearance for the new brake system. *Take careful note of balancing weights.*

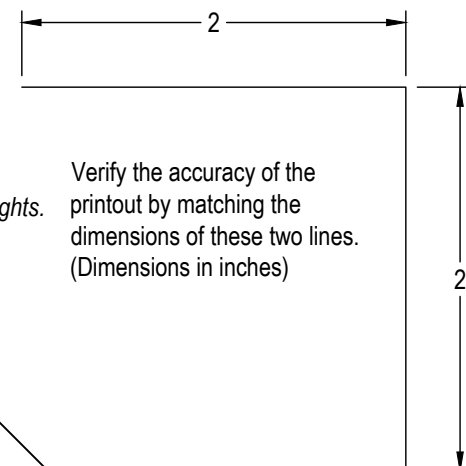

Verify the accuracy of the printout by matching the dimensions of these two lines. (Dimensions in inches)



DINAN

Kit Type: S4R / 370x32mm
 Vehicle: BMW F30 & F80 (Rear)
 Kit #: D290-1006 & D290-1009

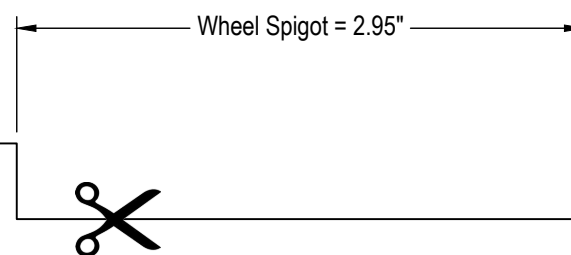

DINAN		www.dinancars.com
<i>WHEEL FITMENT TEMPLATE</i>		
VEHICLE:	BMW F30 & F80 (Rear)	
KIT TYPE:	S4R / 370x32mm Stage-2	
PLATFORM:	BMW08R & BMW11R	
<small>It is critical to accurately check wheel clearance with this template before purchasing your Dinan kit.</small>		