



INSTALLATION INFORMATION ACCEL "POWER PULSE" COIL #140401 & 140402

ACCEL performance coil #140402 is designed to replace Harley Davidson® coil #31609-65A which was original equipment on 1986-79 FL and FX series models and 1967-79 XL series models (except XLCH magnetic models). These models feature 12 volt point triggered ignition systems with mechanical advance through 1977. 1978 and 1979 models incorporate a Prestolite® style breakerless triggered system (V-Fire I) which also used the mechanical advance.

The 140402 coil is also compatible with the V-Fire II Magnavox type Hall cell triggered electronic advance systems used on 1980 and later XL/FL and FX twins. These motorcycles are equipped with Harley Davidson® coil #31609-80.

The ACCEL coil provides an improved KV rating, faster rise time, and longer spark duration than either stock coil and can be used on any 12 volt Harley Davidson model regardless of the type of ignition system.

NOTE: Torque stock mounting nuts (A) to 14 ft./lbs. Use care not to overtighten lead fixing stud bolt (B).

ATTENTION! Do not use metal core wires on 1980 and later V-Fire II equipped models. Use stock suppression core wires or ACCEL heavy-duty 8mm suppression wires as the use of metal core wires may damage or cause RFI problems with the electronic advance module.

CAUTION! On models with points, do not leave ignition key in the "ON" position as this will cause any coil to overheat and fail or possibly explode by permitting the coil (in a closed point mode) to absorb current from the battery. ACCEL coils are not guaranteed in any way if damaged by such a battery run-down condition.

Insist on ACCEL replacement parts for Harley Davidson for the highest quality charging, starting, and ignition components available.

3-542-86

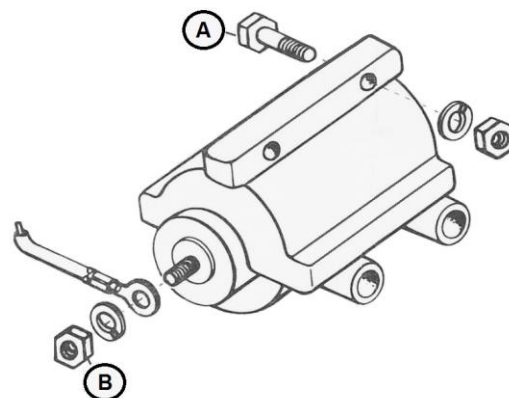

INSTALLATION INFORMATION ACCEL "POWER PULSE" COIL #140401 & 140402

ACCEL performance coil #140402 is designed to replace Harley Davidson® coil #31609-65A which was original equipment on 1986-79 FL and FX series models and 1967-79 XL series models (except XLCH magnetic models). These models feature 12 volt point triggered ignition systems with mechanical advance through 1977. 1978 and 1979 models incorporate a Prestolite® style breakerless triggered system (V-Fire I) which also used the mechanical advance.

The 140402 coil is also compatible with the V-Fire II Magnavox type Hall cell triggered electronic advance systems used on 1980 and later XL/FL and FX twins. These motorcycles are equipped with Harley Davidson® coil #31609-80.

The ACCEL coil provides an improved KV rating, faster rise time, and longer spark duration than either stock coil and can be used on any 12 volt Harley Davidson model regardless of the type of ignition system.

NOTE: Torque stock mounting nuts (A) to 14 ft./lbs. Use care not to overtighten lead fixing stud bolt (B).

ATTENTION! Do not use metal core wires on 1980 and later V-Fire II equipped models. Use stock suppression core wires or ACCEL heavy-duty 8mm suppression wires as the use of metal core wires may damage or cause RFI problems with the electronic advance module.

CAUTION! On models with points, do not leave ignition key in the "ON" position as this will cause any coil to overheat and fail or possibly explode by permitting the coil (in a closed point mode) to absorb current from the battery. ACCEL coils are not guaranteed in any way if damaged by such a battery run-down condition.

Insist on ACCEL replacement parts for Harley Davidson for the highest quality charging, starting, and ignition components available.

3-542-86

