



PRO TWO STAGE SERIES

**NOS Kit Numbers:
02301NOS & 02302NOS (Single 4V)**

**OWNER'S MANUAL
P/N A5077-2-SNOS**

NOTICE: Installation of Nitrous Oxide Systems Inc. products signifies that you have read this document and agreed to the terms stated within.

It is the purchaser's responsibility to follow all installation instruction guidelines and safety procedures supplied with the product as it is received by the purchaser to determine the compatibility of the product with the vehicle or the device the purchaser intends to install the product on.

Nitrous Oxide Systems Inc. assumes no responsibility for damages occurring from accident, misuse, abuse, improper installation, improper operation, lack of reasonable care, or all previously stated reasons resulting from incompatibility with other manufacturers' products.

Nitrous Oxide Systems Inc. assumes no responsibility or liability for damages incurred by the use of products manufactured or sold by Nitrous Oxide Systems Inc. on vehicles used for competition or racing.

Nitrous Oxide Systems Inc. neither recommends nor condones the use of products manufactured or sold by Nitrous Oxide Systems Inc. on vehicles, which may be driven on public roads or highways, and assumes no responsibility for damages incurred by such use.

NOS nitrous oxide is legal for use in most states when used in accordance with state and local traffic laws. NOS does not recommend or condone the use of its products in illegal racing activities.

NOS has not pursued California Air Research Board (CARB) exemptions for these kits, hence, they are not legal for use on pollution-controlled vehicles in California. A correctly installed NOS nitrous system should not alter the emission control performance of your vehicle under standard EPA test cycle conditions.

NOTICE: The NOS Pro Two Stage Series Kit is not intended for use on hatchback type vehicles without the use of NOS part numbers 16160NOS (External Aluminum Blow-Down Tube) and 16169NOS (Racer Safety Pressure Relief Cap).

HAZARDS DEFINED

This manual presents step-by-step instructions that describe the process of installing your NOS Nitrous Oxide Injection System. These procedures provide a framework for installation and operation of this kit. Parts are referenced by name and number to avoid confusion. Within the instructions, you are advised of potential hazards, pitfalls, and problems to avoid. The following examples explain the various hazard levels:

WARNING! Failure to comply with instructions may result in injury or death.

CAUTION! Failure to comply with instructions may result in damage to equipment.

NOTE: This information is important, needs to be emphasized, and is set apart from the rest of the text.

HINT: These special instructions provide a handy work tip.

NITROUS OXIDE INJECTION SYSTEM SAFETY TIPS

WARNINGS

Do not attempt to start the engine if the nitrous has been injected while the engine was not running. Disconnect the coil wire and turn the engine over with the throttle wide open for several revolutions before attempting to start. Failure to do so can result in extreme engine damage.

Never permit oil, grease, or any other readily combustible substances to come in contact with cylinders, valves, solenoids, hoses, and fittings. Oil and certain gases (such as oxygen and nitrous oxide) may combine to produce a flammable condition.

Never interchange nitrous and fuel solenoids. Failure to follow these simple instructions can result in extreme engine damage and/or personal injury.

Never drop or violently strike the bottle. Doing so may result in an explosive bottle failure.

Never change pressure settings of the safety relief valve on the nitrous bottle valve. Increasing the safety relief valve pressure settings may create an explosive bottle condition.

Identify the gas content by the NOS label on the bottle before using. If the bottle is not identified to show the gas contained, return the bottle to the supplier.

Do not deface or remove any markings that are on the nitrous bottle.

Nitrous bottle valves should always be closed when the system is not being used.

Notify the supplier of any condition, which might have permitted any foreign matter to enter the valve or bottle.

Keep the valves closed on all empty bottles to prevent accidental contamination.

After storage, open the nitrous bottle valve for an instant to clear the opening of any possible dust or dirt.

It is important that all threads on the valves and solenoids are properly mated. Never force connections that do not fit properly.

CONGRATULATIONS on purchasing your NOS Nitrous Oxide Injection System. Your system is composed of the highest quality components available. It should provide many miles of trouble-free performance when used correctly. If you have any questions regarding the performance of your system, call NOS Technical Service at 1-866-GOHOLLEY.

TABLE OF CONTENTS

What is Nitrous Oxide?.....	4
Do's and Don'ts of Nitrous Oxide.....	4
Chapter 1 Introduction to Your NOS Nitrous Oxide Kit.....	4
1.1 General Information.....	4
1.2 Pro Two Stage System Requirements.....	5
1.3 Kit Components.....	6
Chapter 2 Kit Installation.....	7
2.1 Bottle Mounting Instructions.....	7
2.1.1 Street Vehicles.....	7
2.1.2 Racing Vehicles.....	7
2.2 Bottle Orientation.....	8
2.3 Bottle Installation.....	8
2.4 Injector Plate Mounting.....	10
2.5 Solenoid Mounting.....	10
2.5.1 Nitrous Solenoid Installation.....	10
2.5.2 Fuel Solenoid Installation.....	10
2.6 Nitrous Feed Line Mounting.....	11
2.7 Fuel Line Connection.....	11
2.8 Electrical System Installation.....	11
Chapter 3 Baseline Tuning Suggestions.....	13
Chapter 4 Preparing for Operation.....	14
Chapter 5 Advanced Tuning for Maximum Power.....	14
5.1 Optimum Nitrous/Fuel Jetting.....	14
5.1.1 Determining Optimum Nitrous/Fuel Jetting.....	14
5.1.2 Determining Optimum Ignition Timing.....	15
Chapter 6 Routine Maintenance.....	17
6.1 Nitrous Solenoid Filter.....	17
6.2 Nitrous Solenoid Plunger.....	17
6.2.1 General Information.....	17
6.2.2 Nitrous Solenoid Plunger Disassembly & Inspection.....	17
Appendix A Troubleshooting Guide.....	19
Nitrous Oxide Accessories.....	21

LIST OF FIGURES AND TABLES

Figure 1 Pro Two Stage System Kit Components.....	7
Figure 2 Nitrous Bottle Siphon Tube Orientation.....	8
Figure 3 Nitrous Bottle Mounting Orientation.....	8
Figure 4 Pro Two Stage Assembly Drawing.....	9
Figure 5 Throttle Microswitch Installation.....	12
Figure 6 Wiring Schematic.....	13
Figure 7 Spark Plug Condition.....	15
Figure 8 Exploded View of Typical Solenoid.....	18
Table 1 Jetting and Power Levels.....	5
Table 2 Pro Two Stage System Kits 02301NOS & 02302NOS Parts List.....	6
Table 3 Suggested Baseline Tuning Combinations.....	14
Table 4 Suggested Baseline Timing Combinations.....	16

WHAT IS NITROUS OXIDE?

NITROUS OXIDE...

...Is a cryogenic gas composed of nitrogen and oxygen molecules

...Is 36% oxygen by weight

...Is non-flammable by itself

...Is stored as a compressed liquid

...Exists in two grades—U.S.P. and Nitrous Plus:

- U.S.P. is medical grade nitrous oxide; its common use is dental and veterinary anesthesia. It is also commonly used as a propellant in canned whipped cream. U.S.P. is not available to the public.
- Nitrous Plus differs from U.S.P., in that it contains trace amounts of sulphur dioxide added to prevent substance abuse. Nitrous Plus is intended for automotive applications and is available for sale to the public

In automotive applications, Nitrous Plus and fuel are injected into the engine's intake manifold, which produces the following results:

- Lowers engine intake air temperature, producing a dense inlet charge.
- Increases the oxygen content of the inlet charge (air is only 22 percent oxygen by weight).
- Increases the rate at which combustion occurs in the engine's cylinders.

Do's and Don'ts of Nitrous Oxide

Do's

- Read **all** instructions before attempting to install your NOS nitrous system.
- Make sure your fuel delivery system is adequate for the nitrous jetting you have chosen. Inadequate fuel pressure or flow **will** result in engine damage.
- Use 14 gauge (minimum) wire when installing electrical system components.
- Use high-quality connections at all electrical joints.
- Use Teflon-based paste on pipe-style fittings.
- Make sure your engine and related components (ignition, carburetor, and driveline) are in proper working condition.
- If nitrous is accidentally injected into the engine when it is not running, remove the engine coil wire, open the throttle, and crank the engine 10 to 15 seconds before starting. Failure to do so can result in an explosive engine failure.**
- Use your NOS nitrous system only at wide-open throttle and at engine speeds above 3000 RPM.**
- Install a proper engine to chassis ground. Failure to do so may result in an explosive failure of the main nitrous supply line.**
- Use a high-quality fuel, as suggested in Chapter 3, Baseline Tuning Suggestions.

Don'ts

- Engage your nitrous system with the engine off. Severe engine damage can occur.
- Modify NOS nitrous systems (if you need a non-stock item, call NOS Technical Service for assistance)
- Overtighten AN-type fittings.
- Use Teflon Tape on any pipe threads. Pieces of Teflon tape can break loose and become lodged in nitrous or fuel solenoids or solenoid filters. Debris lodged in a nitrous or fuel solenoid can cause catastrophic engine failure.



- Use sealant of any kind on AN fittings.
- Allow nitrous pressure to exceed 1100 psi. Excessive pressure can cause swelling or in extreme cases failure of the nitrous solenoid plunger. Solenoid plungers are designed so that pressure-induced failures will prevent the valve from operating. No leakage should occur with this type of failure.
- Inhale nitrous oxide. Death due to suffocation can occur.**
- Allow nitrous oxide to come in contact with skin. Severe frostbite can occur.**
- Use octane boosters that contain methanol. Fuel solenoid failure may occur, producing severe engine damage.**

Chapter 1 Introduction to your NOS Nitrous Oxide Kit

1.1 General Information

NOS Pro Two Stage Series plate systems are intended to work on highly modified domestic V-8 engines of at least 450 cubic inch displacement. Kit numbers 02301NOS & 02302NOS are intended for single 4V applications with standard flange and Dominator Series Holley carburetors. Four jetting levels are supplied, which allow power gains to be easily adjusted from 150-450+ HP. Typical power gains per stage (2-stages) for the Pro Two Stage plate system are as follows:

Table 1 Jetting and Power Levels

Stage	Jetting N ₂ O/Fuel	Fuel Quality	Ignition Timing	Spark Plug Heat Range
150 HP	63/59	100+ octane (R+M/2) racing fuel	*	-9
200 HP	73/67	110+ octane (R+M/2) racing fuel	*	-10
225 HP	82/76	110+ octane (R+M/2) racing fuel	*	-10
250 HP	93/85	112+ octane (R+M/2) racing fuel	*	-11

* See section 5.1.2 for timing recommendations

NOTE: All jetting is determined by using 950PSI bottle pressure and 6 PSI fuel pressure

When using the 93/93 jetting combination, the Cheater nitrous solenoid is flowing at maximum capability. Increasing jetting sizes beyond these levels will not result in a performance increase.

A full bottle will weigh 25 lbs. For best performance, the bottle should be refilled when it weighs 17 to 18 lbs.

1.2 Pro Two Stage System Requirements

When used correctly, NOS nitrous oxide injection elevates cylinder pressures and temperatures while increasing the combustion rate. These characteristics make the engine more sensitive to detonation. **To ensure proper performance and engine life, the following are absolute musts:**

Adequate Fuel Pressure and Delivery

Most carburetors are designed to operate at 5 psi to 10 psi. When purchasing your fuel system components, plan on your pumps and lines flowing at least 0.10 gallons per hour per horsepower at 5 psi. For alcohol applications, double this number.

NOTE: Most fuel pumps are rated at free-flowing conditions—at 5 psi fuel pressure, their flow rates may be greatly reduced.

Forged Pistons

Cast pistons are very prone to failure at elevated cylinder temperatures and pressures.

Connecting Rods

Standard type forged connecting rods tend to buckle under the high compressive loads generated with large doses of nitrous oxide. Aftermarket steel or aluminum units are suggested.

Crankshaft

Stock-type cast crankshafts are breakage prone. Stock-type forgings can bend or twist in high-output applications. Aftermarket forgings are recommended.

Cylinder Block

Four-bolt main caps blocks reduce the tendency for the main caps to “walk” under high-output loading. Cylinder head studs decrease the chance of cylinder heads lifting or moving relative to the cylinder block deck surface.

High Output Ignition System

Stock-type ignition systems are prone to producing misfires at high-RPM, when subjected to high cylinder pressures. A quality aftermarket racing ignition is suggested for all applications.

Intake Manifold

Due to the high flow rates of nitrous oxide and fuel that are attained with this kit, it is suggested that an intake with an open plenum (single plane) be used. Intake manifolds that feature individual orifices for each carburetor butterfly should not be used with the Pro Two Stage Kit.

1.3 Kit Components

Before beginning the installation of your NOS kit, compare the components in your kit with those shown in Figure 1, and listed in Tables 2 & 3. If any components are missing, please contact NOS Technical Support at 1-866-GOHOLLEY.

Table 2 Pro Two Stage System Kits 02301NOS & 02302NOS Parts List

Item	Description	Quantity	NOS P/N
(1)	6AN Bottle Nut Adapter	1	16230-SNOS
(2)	Teflon Bottle Nut Washer	1	16210-SNOS
(3)	Bottle Bracket Set (Steel)	1	14125-SNOS
(4)	10 lb. Nitrous Bottle	1	14745-SNOS
(5)	Injector Plate	1	*
(6)	Carburetor Studs	4	*
(7)	Carburetor Gaskets	2	*
(8)	Nitrous Cheater Solenoid	2	16000NOS
(9)	Fuel Cheater Solenoid	2	16050NOS
(10)	4AN x 1/4" NPT Nitrous Filter	2	15560-SNOS
(11)	Solenoid Mounting Bracket	4	16500-SNOS
(12)	"Flarejet" Assortment—Jetpack***	2	13726NOS
(13)	12" 4AN x 3AN Hose (Blue)	2	15340-SNOS
(14)	12" 4AN x 3AN Hose (Red)	2	15341-SNOS
(15)	6AN TEE (Blue)	1	17815-SNOS
(16)	12" 4AN x 6AN Hose (Blue)	2	15350-SNOS
(17)	1/8" NPT x 4AN Fitting (Blue)	2	17960-SNOS
(18)	1/8" x 6AN Fitting (Red)	2	17986-SNOS
(19)	1/8" NPT x 4AN Fitting (Red)	2	17961-SNOS
(20)	14 ft. 6AN hose (Blue)	1	15475-SNOS
(21)	Microswitch & Bracket**	1	15640-SNOS
(22)	30 AMP Relay & Wiring Harness	2	15618-SNOS
(23)	Arming Switch	1	15602-SNOS
(24)	Activation Pushbutton	1	15610-SNOS

*Varies with application. **Wiring and connectors also supplied. ***Includes: 63,73,82 & 93.

Figure 1 Pro Two Stage System Kit Components

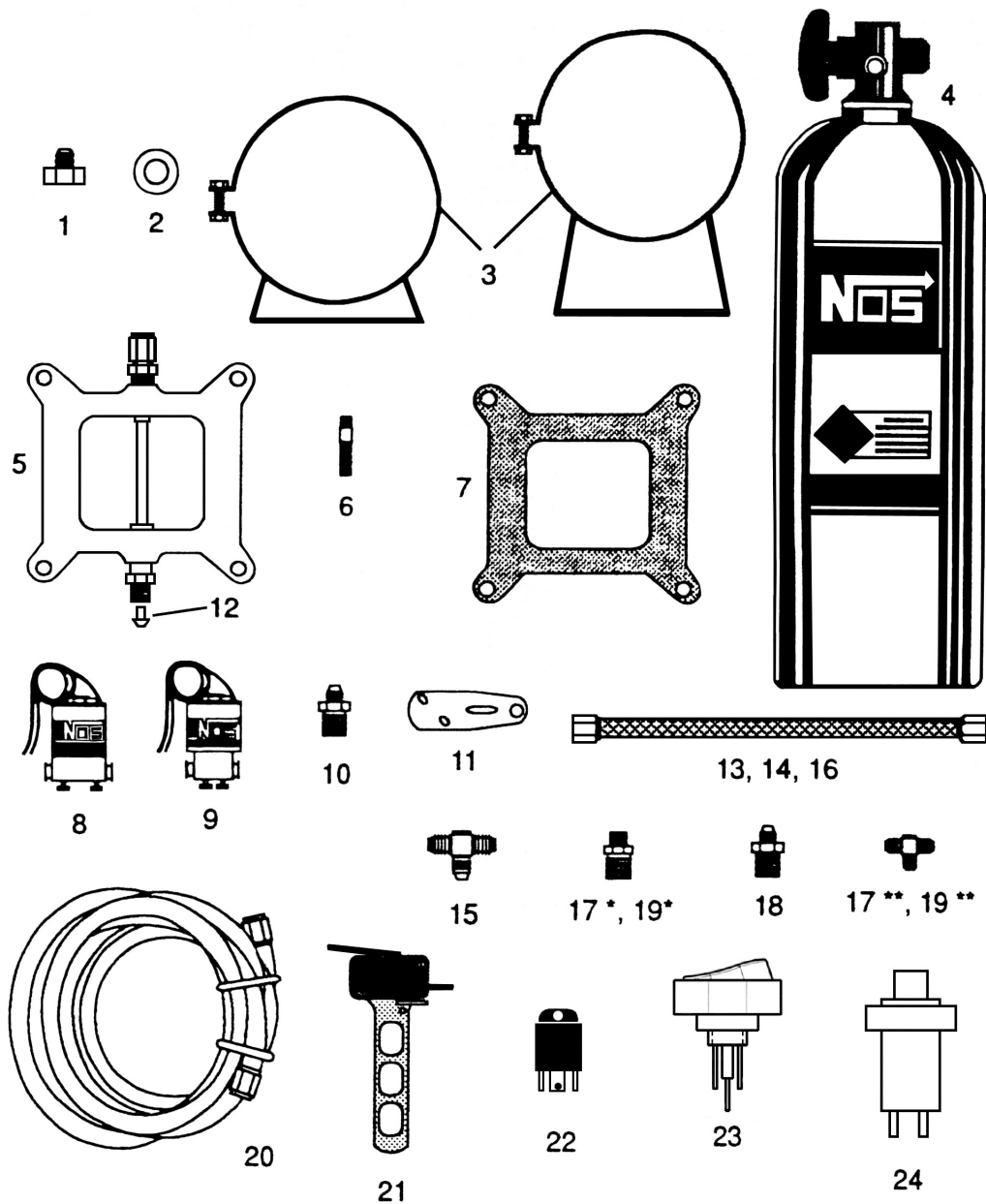

Chapter 2 Kit Installation

2.1 Bottle Mounting Instructions

NOTE: Disconnect the battery ground before beginning installation.

2.1.1 Street Vehicles

Accurate calibration of your NOS nitrous system depends on the bottle remaining at a stable temperature. In vehicles (such as Corvettes) where the bottle must be mounted in an area subject to direct sunlight, it is suggested that the bottle be shielded with a bottle blanket. Additionally, if the bottle is mounted inside the passenger compartment, the safety blow-down valve must be vented externally from the cockpit. This procedure will prevent the passenger compartment from filling with a cloud of nitrous oxide if the safety pressure relief cap should happen to rupture.

2.1.2 Racing Vehicles

Before mounting a nitrous bottle in a racing vehicle intended for use in sanctioned events, check with the sanctioning association for any rules regarding this subject. Most associations require the bottle to be mounted within the confines of the safety roll cage with the safety pressure relief cap vented away from the driver's compartment.

Figure 2 Nitrous Bottle Siphon Tube Orientation

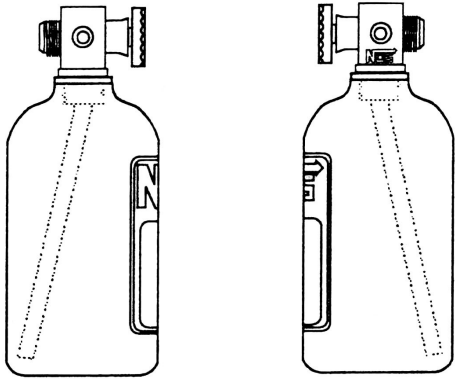
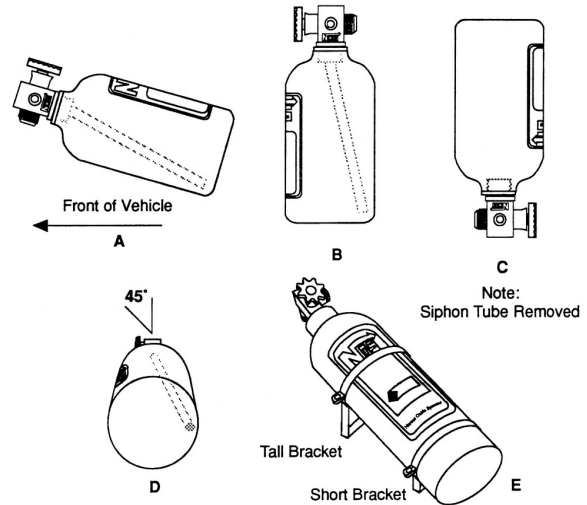

Figure 3 Nitrous Bottle Mounting Orientations



2.2 Bottle Orientation

Bottle placement is critical to the performance of your NOS nitrous system. It is important to understand how the bottle valve and siphon tube are assembled to properly orient the bottle in your vehicle and ensure that it picks up liquid nitrous while undergoing acceleration. All NOS nitrous bottles are assembled so that the bottom of the siphon tube is at the bottom of the bottle and opposite the bottle label (Figure 2).

Whenever the bottle is mounted in a lay-down position, the valve handle must be towards the front of the vehicle with the label facing up (Figure 3A).

If the bottle is mounted vertically, the valve handle and label must face toward the front of the vehicle (Figure 3B). This orientation will position the siphon tube at the back of the bottle where the liquid N_2O will be during acceleration.

WARNING! DO NOT attempt to remove the siphon tube without completely emptying the bottle of all nitrous and pressure. Failure to completely empty the bottle will result in an explosive condition causing injury or death.

A bottle mounted upside-down must have the siphon tube removed before use (Figure 3C). Non-siphon bottles can be specially ordered from NOS.

If the bottle must be mounted parallel to the axles of the vehicle (sideways), the valve handle and label must be angled at approximately 45° toward the front of the vehicle (Figure 3D). This orientation will position the siphon tube toward the rear of the bottle.

NOTE: When using a bottle with a siphon tube, the tall bracket should be at the valve end of the bottle and the short bracket at the bottom (Figure 3E).

The most efficient mounting is the lay-down position (Figure 3A) with the valve handle toward the front of the vehicle. This position allows the greatest amount of liquid to be used before the siphon tube begins to pick up gaseous nitrous oxide.

2.3 Bottle Installation

After you have determined the location and orientation of the nitrous bottle, use the following procedure to install the bottle:

NOTE: Numbers in parentheses () refer to the parts list /assembly drawing number for the component (Figure 1). Figure 4 shows the installation assembly for the Pro Two Stage Series Kit numbers 02301NOS & 02302NOS for single 4V applications. Figure 5 shows the installation assembly for the Pro Two Stage Series Kit numbers 02310NOS & 02311NOS for dual 4V applications.

1. Install the bottle nut adapter (1) and washer (2) on the nitrous bottle (4), and tighten securely.
2. Loosely install the bottle mounting brackets (3) on the nitrous bottle.
3. Locate the bottle assembly in the desired mounting location, ensuring that the location will provide easy access to the bottle valve, hose connection, and bracket clamp bolts to facilitate bottle changing.
4. Use the assembled bottle/bracket unit as a pattern to mark and drill four $5/16$ " holes in the mounting surface.

5. Mount the brackets securely to the surface (recommended minimum of 5/16" bolts or No. 12 sheet metal screws).
6. Tighten the bracket clamps on the bottle.

Figure 4 Pro Two Stage System Assembly Drawing Kit Numbers 02301NOS & 02302NOS—Single 4V

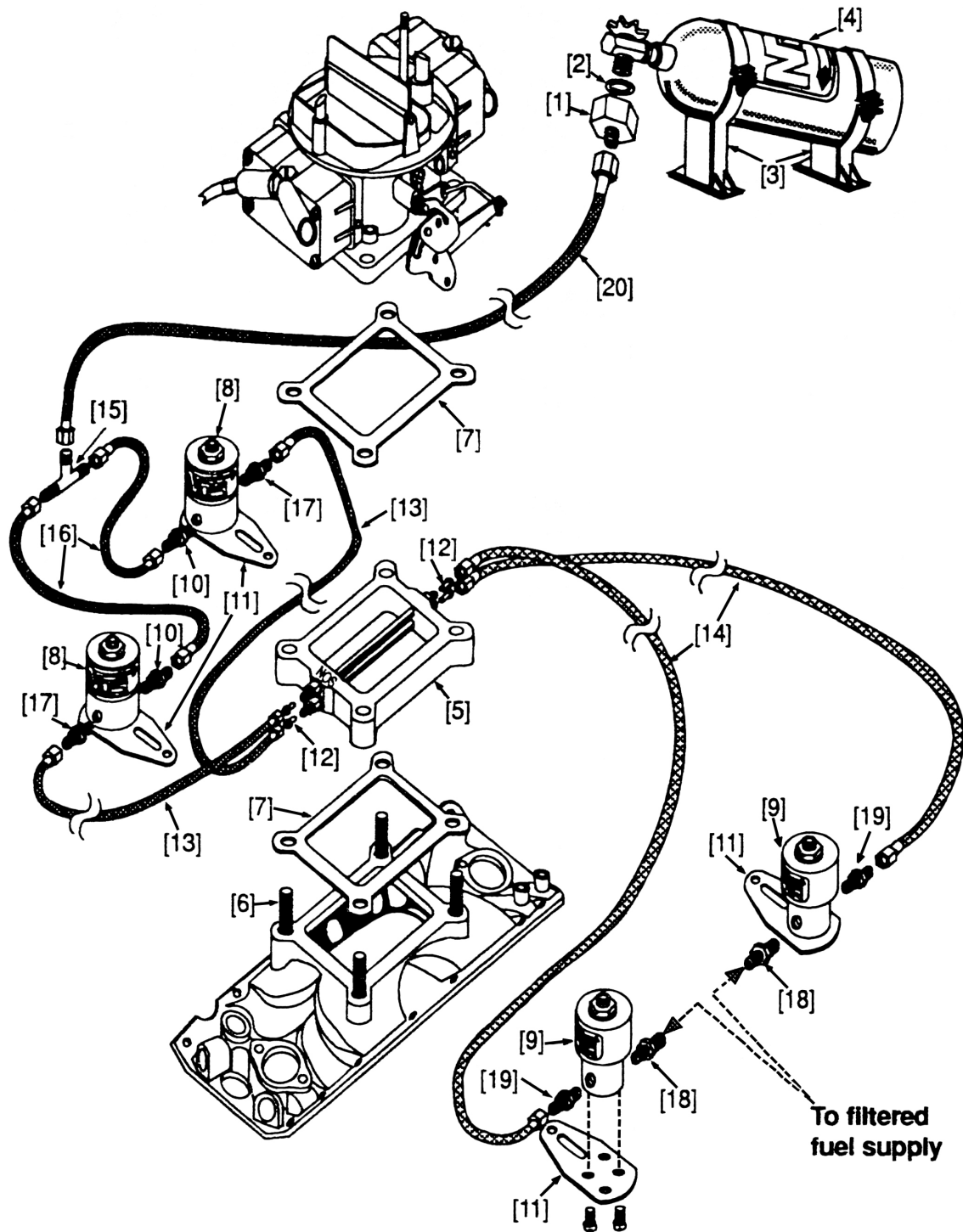

2.4 Injector Plate Mounting

Use the following procedure to install the injector plate (5):

1. Remove the carburetor inlet ducting and air cleaner.
2. Disconnect the throttle linkage from the carburetor.
3. Disconnect the fuel line from the carburetor.
4. Remove the carburetor.
5. Remove the stock carburetor studs.
6. Install the extended carburetor studs (6).
7. Install the injector plate (5) and gaskets (7) on the intake manifold with the NOS label facing up. See Figure 4 or 5 for the illustration of the part installation.
8. Install the carburetor.
9. Connect the throttle linkage.

2.5 Solenoid Mounting

Use the following procedure to install the nitrous solenoid (8) and fuel solenoid (9). See Figure 4 or 5 for an illustration of part installation.

NOTE: Remember to use Teflon paste **only** on the pipe threads.

2.5.1 Nitrous Solenoid Installation

CAUTION: Do not overtighten the vise in the following procedure, or the solenoid will be damaged.

1. Clamp the nitrous solenoid (8) base in a bench vise.
2. Install the nitrous filter fitting (10) in the inlet port of the nitrous solenoid.
3. Install a 1/8" NPT x 4AN blue adapter (17) in the outlet port of the nitrous solenoid.
4. Attach the solenoid mounting bracket (11) to the nitrous solenoid.
5. Loosely mount the nitrous solenoid near the base of the carburetor on the nitrous (blue) end of the injector plate.

NOTE: When selecting nitrous and fuel jets, make sure that you properly match up the stages (correctly pair N₂O/Fuel jets).

6. Install the proper nitrous jet (12) in the injector plate (See Section 1.1) with the beveled edge out.
7. Connect the nitrous solenoid outlet port to the injector plate using the 12" 4AN x 3AN hose (blue) (13).
8. Tighten the solenoid mount.
9. Repeat for second stage nitrous solenoid.

2.5.2 Fuel Solenoid Installation

CAUTION: Do not overtighten the vise in the following procedure, or the solenoid will be damaged.

1. Clamp the fuel solenoid (9) base in a bench vise.
2. Install 1/8 NPT x 6AN Fitting (Red) (18) in the inlet port of the fuel solenoid.
3. Install a 1/8" NPT x 4AN fitting (Red) (19) in the outlet port of the fuel solenoid.
4. Attach the solenoid mounting bracket (11) to the fuel solenoid.
5. Loosely mount the fuel solenoid near the fuel (red) end of the injector plate (5).

NOTE: When selecting nitrous and fuel jets, make sure that you properly match up the stages (correctly pair N₂O/Fuel jets).

6. Install the proper fuel jet (12) in the injector plate (See Section 1.1) with the beveled edge out.
7. Connect the outlet port of the fuel solenoid to the injector plate using the 12" 4AN x 3AN Hose (red) (14).
8. Tighten the solenoid mount.
9. Repeat for second stage fuel solenoid.

2.6 Nitrous Feed Line Mounting

HINT: Most late model vehicles have access plugs in the trunk floor that are convenient for line routing. Following the fuel lines along the underbody, and entering the engine bay through the front fender well between the plastic inner fender panel and the body usually works well.

1. Determine the route for your nitrous feed line to follow. Ensure the path is clear of exhaust system, suspension, steering, wheels, electrical lines and components, and tires.
2. Feed the main nitrous supply line (20) along the proposed route.
3. If it is necessary to support the nitrous supply line under the vehicle, use 1/2" Tinnerman clamps or nylon tie-wraps to support the line securely.
4. Attach the nitrous supply line to the nitrous bottle valve adapter (1).

WARNING: Nitrous oxide can cause death if inhaled. Severe frostbite can occur if allowed to contact the skin. Always point the nitrous line opening away from people when purging the line.

5. Purge the nitrous supply line.
 - A. Wrap the end of the nitrous line with a rag and hold securely.
 - B. Point the opening away from people.
 - C. Briefly open the bottle valve.
6. Attach the nitrous supply line to the center leg of the 6AN TEE (15).
7. Connect the 6AN TEE to the nitrous solenoid inlet ports using the 4AN x 6AN 12" hoses (16).

2.7 Fuel Line Connection

1. Connect the 6AN Fittings (18) in the fuel solenoid inlet ports to the filtered fuel supply.

2.8 Electrical System Installation

Refer to (Figure 5) for throttle microswitch installation. Refer to the wiring schematic (Figure 6) for electrical system installation.

WARNING! Death or injury may occur from working on a charged electrical system.

1. Disconnect the car battery at the ground cable (if not already done).

WARNING! Binding or dragging of the throttle linkage will create a potentially dangerous stuck-throttle condition. Ensure that the microswitch does not interfere with normal throttle linkage operation.

2. Install the throttle microswitch (21) as follows:

HINT: The microswitch may be mounted to the bracket in a variety of positions and on either side of the bracket. The bracket may be bent to suit the application.

- A. Mount the throttle microswitch on the carburetor, so that the throttle linkage movement triggers the microswitch.
- B. Adjust the microswitch to trigger at wide-open throttle by adjusting the microswitch's position to ensure the actuation arm of the microswitch "clicks" at the same point your throttle linkage reaches wide-open throttle against the throttle stop (Position 5A).
- C. Ensure that the microswitch is activated by the accelerator pedal: Slowly press the throttle to the floor while you listen for the "click" of the microswitch (Position 5B).

Figure 5 Throttle Microswitch Installation

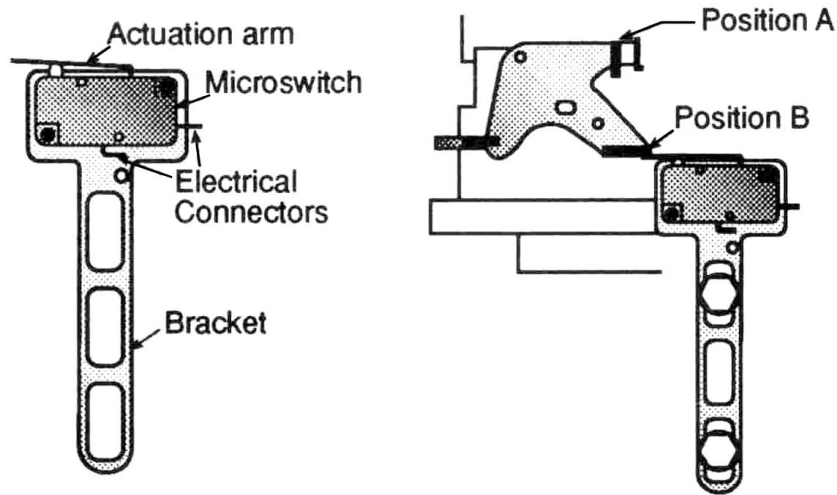

3. Install the NOS arming switch (23) in the vehicle's interior, within easy reach of the driver.
4. Install the second stage activation pushbutton (24) in the vehicle's interior, within easy reach of the driver.
2. Connect the terminal away from the LED on the arming switch to an ignition switched +12V source.
3. Connect the center terminal of the arming switch to one post of the throttle microswitch.
4. Connect the terminal closest to the LED on the arming switch to the ground.
5. Install the first stage relay and relay harness (22) in the engine compartment near the battery. The relay's orange wire should reach the battery (+) terminal. Hint: The 12V (+) terminal on the alternator or accessory powerpole also works well.
6. Install the second stage relay and relay harness (22) in the engine compartment near the battery. The relay's orange wire should reach the battery (+) terminal. Hint: The 12V (+) terminal on the alternator or accessory powerpole also works well.
7. Connect the red wire from relay #2 to one post on the activation button.
8. Connect the open post of the activation pushbutton and the red wire from relay #1 to the open post on the throttle microswitch.
9. Connect the green wire from relay #1 and the green wire from relay #2 to the ground.
10. Connect the blue wire from relay #1 to one wire from the stage one nitrous solenoid and one wire from the stage one fuel solenoid.

NOTE: Either wire will do. The solenoids are not polarized.

11. Connect the remaining wires from the stage one nitrous solenoid and the stage one fuel solenoid.
12. Connect the blue wire from relay #2 to one wire from the stage two nitrous solenoid and one wire from the stage two fuel solenoid.

NOTE: Either wire will do. The solenoids are not polarized.

13. Connect the remaining wires from the stage two nitrous solenoid and the stage two fuel solenoid to the ground.
14. Connect the orange wire from each relay to the battery (+) terminal.

Figure 6 Wiring Schematic

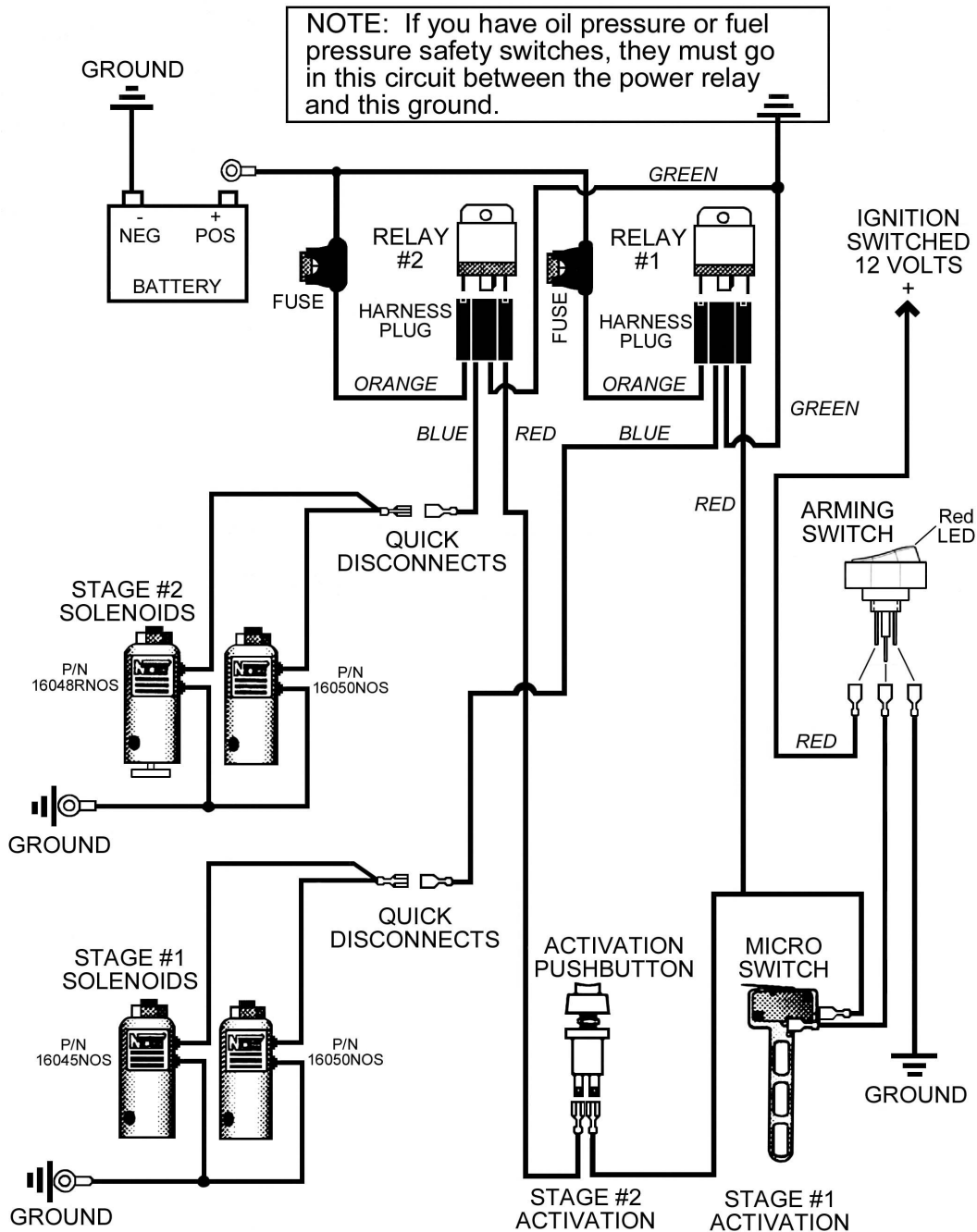

Chapter 3 Baseline Tuning Suggestions

Your NOS Pro Two Stage System Kit comes with four sets of nitrous and fuel jets. These are conservative jetting combinations, based upon 950 psi nitrous oxide bottle pressure and 5 to 6 psi flowing fuel pressure. Operating with these pressure levels should yield safe and reliable power increases.

Using these jetting combinations with lower bottle pressure and/or higher fuel pressure may produce an excessively rich condition. This can result in a loss of power, excessive exhaust smoke (black), or misfiring (backfiring through the exhaust). This condition may also arise if your carburetor is jetted excessively rich.

If you experience any of these conditions, or you desire to maximize the power output from your system, refer to Chapter 5, "Advanced Tuning for Maximum Power".

CAUTION: Use of excessive bottle pressure and/or inadequate fuel pressure can result in an excessively lean condition. In extreme cases, this will produce catastrophic engine failure.

Table 3 Suggested Baseline Tuning Combinations

Stage	Jetting N ₂ O/Fuel	Fuel Quality	Ignition Timing	Spark Plug Heat Range
150 HP	63/59	100+ octane (R+M/2) racing fuel	*	-9
200 HP	73/67	110+ octane (R+M/2) racing fuel	*	-10
225 HP	82/76	110+ octane (R+M/2) racing fuel	*	-10
250 HP	93/85	112+ octane (R+M/2) racing fuel	*	-11

* See section 5.1.2 for timing recommendations

NOTE: All jetting is determined by using 950PSI bottle pressure and 6 PSI fuel pressure

At the stage 250 HP jetting level, the Cheater nitrous solenoid is flowing at maximum capability. Increasing jetting levels beyond this point will not provide a performance increase. If you need performance greater than 250 HP delivers, contact NOS Technical Support for information on higher flow rate solenoids and other related parts.

Chapter 4 Preparing for Operation

After you have completed the installation of your NOS Pro Two Stage System kit, perform the following checkout procedure before operating your vehicle.

NOTE: Before performing steps 1-4, make sure that the nitrous bottle valve is closed and the main nitrous supply line is empty.

1. Turn on the fuel pump.
2. Check all the fuel lines and fittings for leaks.
3. Start the engine.
4. Turn the arming switch on. Set the engine speed at 2000 RPM. Briefly depress the activation arm on the microswitch. Engine speed should decrease if the fuel delivery system is performing properly; if not, refer to Appendix A, Troubleshooting Guide.
5. Open the nitrous bottle valve.

NOTE: There should be no change in the engine idle speed. If idle speed changes, refer to Appendix A, Troubleshooting Guide.

6. Inspect the nitrous lines and fittings for leaks.
7. ENJOY!

Chapter 5 Advanced Tuning for Maximum Power

Optimum Nitrous/Fuel Jetting

After performing the Baseline Tuning Suggestions—Chapter 3, if you desire to maximize the performance of your system, perform the following:

NOTE: Always perform the nitrous/fuel jetting modifications listed in Section 5.1.1 before attempting to optimize the ignition timing (Section 5.1.2). Improper nitrous/fuel jetting combinations can mislead you when attempting to optimize the ignition timing.

5.1.1 Determining Optimum Nitrous/Fuel Jetting

The jetting combinations included in your kit are compromises, intended to provide you with a safe starting point. They are intended to be used with 950 psi nitrous bottle pressure and 6 psi flowing fuel pressure. In many instances, installing slightly smaller fuel jets than the units provided in your kit will provide a more optimum nitrous/fuel ratio and increase power.

Always run the baseline jetting included in your kit before attempting to decrease fuel jet size. Optimum jetting can be determined using the following scheme. Stabilize the nitrous bottle pressure at 950 psi.

Perform a dynamometer pull or a full throttle pass down the racetrack. Note the power reading or vehicle mph (not e.t.). Examine the spark plugs for the indication of lean or rich nitrous/fuel conditions (refer to Figure 8 for tips on reading the spark plugs).

- 2A. If spark plugs appear to be excessively rich, decrease the fuel jet size 2 steps (ex. 93 to 91, 102 to 100, etc;).
 - 2B. If spark plugs appear to be excessively lean, increase the fuel jet size 2 steps.
 - 2C. If spark plugs have a "like new" appearance on the porcelain and electrode, do not make a fuel jetting change.
3. Repeat steps 1 and 2 until the desired mixture is obtained.

How to Read Spark Plugs form a Nitrous Oxide Injected Engine

A. Correct Timing, Mixture, and Spark Plug Heat Range

Ground strap retains a "like new" appearance. Edges are crisp, with no signs of discoloration. Porcelain retains clear white appearance with no "peppering" or spotting.

B. Excessively Rich Mixture

Porcelain may be fuel stained, appearing brown or black. In extreme cases, ground strap, electrode, and porcelain may be damp with gasoline, or smell of fuel.

C. Detonation

Edges of the ground strap may become rounded. Porcelain has the appearance of being sprinkled with pepper, or may have aluminum speckles. During heavy detonation, the ground strap tip may burn off. This phenomena can result from excessive ignition timing, too high a heat range spark plug, or inadequate fuel octane.

D. Excessively Lean Mixture

Edges of the ground strap may become rounded. Under moderate overheating, the tip of the ground strap can discolor, usually turning purple, or the entire ground strap can become discolored.

Figure 7 Spark Plug Condition

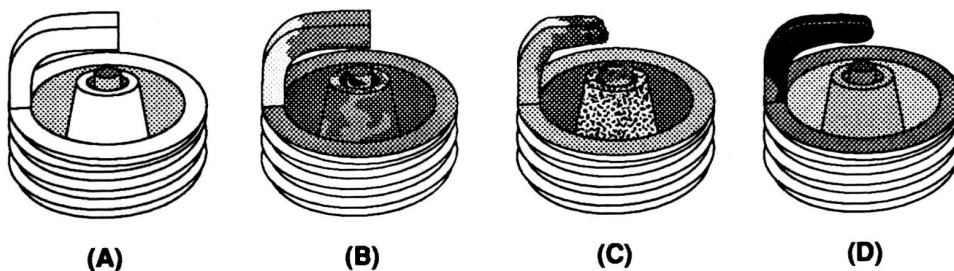

5.1.2 Determining Optimum Ignition Timing

Determining the correct ignition timing for an engine using nitrous oxide is not cut and dry as it is dependent on many variables. Variables such as piston design, combustion chamber size and design, valve angle, fuel type, nitrous system design, and other factors all play a critical role as to what timing a specific engine/vehicle combination needs. When running larger amounts of nitrous, it is critical that the proper ignition timing be run as well as the proper spark plug heat range.

There is one specific timing that is most ideal for a specific engine and nitrous tune-up. In the end the best and correct method to determine timing in a car is to read the spark plugs.

Due to all these variables, it is difficult to recommend a generic timing for a given amount of nitrous. However the information below is intended to provide a starting point. After this, it is best to use the spark plugs as an indicator as to what timing a specific engine requires. The spark plugs also will help with nitrous and fuel jetting as well as fuel pressure needs.

One large variable that drives the ideal ignition timing is the "combustion efficiency". This is a combination of the cylinder head valve angle, combustion chamber size and burn characteristics, and piston dome design among other things. The more efficient the overall combustion efficiency is, the less timing is needed with nitrous. Note that when running large amount of nitrous, the old school rule of "take out two degrees per 50 HP of nitrous" is not ideal or wise.

The following timing recommendations below are based on nitrous HP amounts and a factor called "Combustion Efficiency". Combustion Efficiency takes into account the piston dome, chamber size, valve angle, and other factors. It is split up into three categories, "High", "Medium", and "Low". The following reviews these:

"High" – An engine with an exceptionally efficient and quick burn rate when running nitrous. Typically this would have a piston with a dish, flattop, or very small, flat dome design. Combustion chambers are small and valve angles are greatly reduced from the "factory" valve angle. Generic examples are engines with current high end race heads that have valve angles reduced 7-11 from stock, very small combustion chambers, and flat top piston that still maintain 13-14:1 compression ratios.

“Medium” – An engine with a small and efficient chamber. An example could be a SBC with an 18 degree head with a moderate piston dome.

“Low” – Older engines with factory valve angles. Pistons may have large domes to maintain high compression ratios. Large, open combustion chambers. An example would be a BBC engine with a 119cc open chamber and large dome piston.

The following are some initial recommendations for timing. Be conservative and read your plugs. Run an 1/8th mile hit rather than a 1/4 mile pass to start to see initial plug strap readings. The “Plug” recommendation is based on NGK heat ranges. An equivalent Autolite or other brand can be used.

Note: These are for V8’s. For a 4 cylinder, cut these numbers in half.

Table 4 Suggested Baseline Timing Combinations

Nitrous HP	Combustion Efficiency	Timing	NGK Spark Plug or Equiv.	Fuel/Octane
100	Low	32	Stock	93+
100	Medium	30	Stock	93+
100	High	28	Stock	93+
125	Low	31	Stock/-7	100+
125	Medium	29	Stock/-7	100+
125	High	27	Stock/-7	100+
150	Low	29	-8	100+
150	Medium	27	-8	100+
150	High	25	-8	100+
175	Low	27	-9	110+
175	Medium	25	-9	110+
175	High	23	-9	110+
200	Low	24	-9	110+
200	Medium	22	-9	110+
200	High	20	-9	110+
250	Low	22	-10	112+
250	Medium	29	-10	112+
250	High	18	-10	112+
300	Low	20	-11	114+
300	Medium	18	-11	114+
300	High	16	-11	114+
350	Low	18	-11	114+
350	Medium	16	-11	114+
350	High	14	-11	114+

Chapter 6 Routine Maintenance

6.1 Nitrous Solenoid Filter

When nitrous bottles are refilled they can become contaminated with debris, if the refiller does not have an adequate filter in his transfer pump mechanism. Contaminants in the bottle will eventually become lodged in the nitrous solenoid filter fitting.

You should periodically (after every 20-30 pounds of nitrous usage) examine the mesh in the nitrous filter for debris.

To clean the filter, follow the following steps:

Close the valve on the nitrous bottle.

Empty the main nitrous feed line.

Disconnect the main nitrous feed line from the nitrous solenoid.

Remove the nitrous filter fitting from the nitrous solenoid.

Remove **all** Teflon paste debris from the solenoid inlet port threads and from the nitrous solenoid filter pipe threads.

Examine the mesh in the nitrous filter fitting for contaminants. Blow out debris with compressed air, if necessary.

Apply fresh Teflon paste to the nitrous filter pipe threads. Reinstall the filter in the nitrous solenoid.

Reconnect the main nitrous supply line to the nitrous solenoid.

6.2 Nitrous Solenoid Plunger

6.2.1 General Information

The seals used in NOS nitrous solenoid plungers are constructed from materials, which are designed to be used with nitrous oxide. When kept free from fuel contaminants or from overpressurization, they should provide trouble free performance.

You should periodically (after every 20-30 pounds of nitrous usage) examine the seal in the nitrous solenoid plunger.

Due to the Pro Two Stage System being a wet manifold style nitrous kit, the nitrous solenoid plunger will get exposed to fuel vapors. This is unavoidable. Fluctuations in the intake manifold pressure due to opening and closing of the throttle induce flow into the out of the NOS injector plate spray bars (fuel and nitrous), when the NOS system is not in use. Long term exposure of the nitrous solenoid plunger seal to the fuel vapors will result in swelling of the plunger seal. This will reduce the nitrous flow (causing an excessively rich nitrous/fuel condition and a loss of power).

The seals used in NOS nitrous solenoid plungers are designed to work at pressures up to 1100 psi. Exposing the plunger to excessive pressure (whether the vehicle is sitting or in-use) can result in the seal in the plunger swelling or in extreme cases disintegrating.

NOTE: The seals are designed so that if they fail due to overpressurization, they will not leak, the valve will just fail to flow nitrous oxide.

Swelling of the nitrous solenoid plunger seal will reduce nitrous flow (causing an excessively rich nitrous/fuel condition and a loss of power).

6.2.2 Nitrous Solenoid Plunger Disassembly and Inspection

Close the valve on the nitrous bottle.

Empty the main nitrous supply line.

Remove the retaining nut from the nitrous solenoid.

Remove the coil and housing from the nitrous solenoid base.

Unscrew the stem from the nitrous solenoid base. Do this by double nutting the stem, or by using a solenoid stem removal tool (NOS P/N 16666-SNOS), which is included in all solenoid overhaul kits. **Do not use pliers on the solenoid stem. Damage to the stem will result.**

Remove the stem, spring, and plunger from the solenoid base.

Examine the plunger seal for swelling. The seal surface should be flat, except for a small circular indentation in the center of the seal;

A fuel-contaminated seal will protrude from the plunger and be dome-shaped. A fuel-contaminated seal may return to its original shape if left out in the fresh air for several days. It may then be returned to service.

A seal, which has been overpressurized, may be dome-shaped, or the sealing surface may be flat with the seal protruding out of the plunger. A dome-shaped seal may return to its original shape if left out in the fresh air for several days. It may then be returned to service. A seal, which is flat, but protrudes from the plunger body has probably failed internally and should be replaced.

Figure 8 Exploded View of a Typical Solenoid

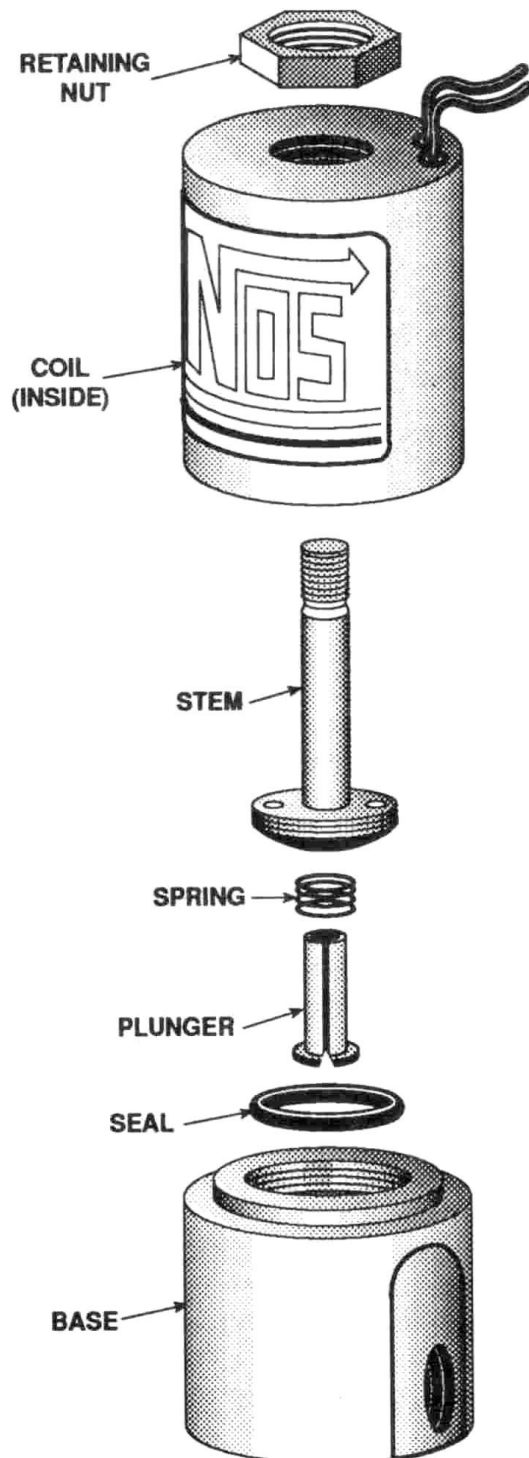

Appendix A Troubleshooting Guide

The troubleshooting chart on the following pages should help determine and rectify most problems with your installed NOS system. If you still need assistance determining or fixing problems, call the NOS Technical Support at 1-866-GOHOLLEY.

PROBLEM	POSSIBLE CAUSES	DIAGNOSTIC PROCEDURE	CORRECTIVE ACTION
No change in engine speed when the fuel solenoid is activated (Preparing for Operation—Chapter 4).	System wired incorrectly.	Compare wiring to schematic (Figure 7).	Wire per instructions.
	Restricted fuel line.	Inspect fuel line for restrictions (crimped or plugged).	Remove restrictions.
	Malfunctioning fuel solenoid.	Turn arming switch ON. Activate microswitch. Solenoid should make “clicking” noise.	Repair/replace solenoid.
Change in engine speed when nitrous bottle valve is opened (Preparing for Operation—Chapter 4).	Malfunctioning nitrous solenoid.	Remove and inspect solenoid.	Repair/replace solenoid.
Engine runs rich when system is activated.	Bottle valve not fully opened.	Check bottle valve.	Open valve fully.
	Bottle mounted improperly.	Check bottle orientation.	Mount bottle properly.
	Plugged nitrous filter.	Inspect filter.	Clean/replace filter.
	Low bottle pressure.	Check bottle temperature.	Set bottle temperature to 80° to 85°F.
	Inadequate nitrous supply.	Weigh bottle.	Fill bottle. 1-800-99-REFILL
	Mismatched N ₂ O/fuel jetting.	Compare jetting to recommended values.	Install correct jets.
	Excessive fuel pressure.	Install fuel pressure gauge, such as NOS P/N 15931NOS, in the fuel line. Measure the pressure during acceleration with the system activated.	Regulate pressure down, or install smaller fuel jetting.
	Loose nitrous solenoid wiring.	Inspect the solenoid wiring.	Repair wiring.
Malfunctioning nitrous solenoid.	WARNING: <i>Solenoid discharges nitrous at a high rate. Don't inhale nitrous; death may occur. Skin contact may cause frostbite.</i> Close bottle valve. Disconnect the nitrous solenoid outlet port. Disconnect the solenoid (+) lead. Open the nitrous bottle valve. Briefly connect the +12V to the solenoid. Solenoid should discharge N ₂ O at a high rate.	Rebuild solenoid.	
No change in performance when system is activated.	System wired incorrectly.	Compare nitrous wiring to schematic. (Figure 7)	Wire system per instructions.
	Loose ground wire(s).	Connect 12V test light to battery (+) terminal. Check for continuity at grounds noted in schematic.	Tighten/repair loose ground(s).
	Malfunctioning pushbutton.	Turn bottle valve off. Turn arming switch on. Connect 12V test light to battery (-) terminal. Turn pushbutton switch on. Check for continuity at pushbutton output pole.	Replace pushbutton
	No power to arming switch.	With vehicle ignition ON, connect 12V test light to battery (-) terminal. Check for power at pole #1 on arming switch.	Repair wiring.
	Malfunctioning arming switch.	With vehicle ignition ON, turn arming switch ON. Connect 12V test light to battery (-) terminal. Check for power at red wire on arming switch.	Replace arming switch.
	Overly rich fuel condition.	Check for black smoke or backfiring through exhaust with system activated.	Install smaller fuel jet or decrease fuel pressure.

	Malfunctioning throttle microswitch.	Temporarily disconnect power relay green wire from microswitch. Connect 12V test light to battery (+) terminal. Manually set microswitch on. Check for continuity at microswitch positive terminals. (Figure 7)	Replace throttle microswitch.
Engine detonates mildly when system is activated.	Excessive ignition timing.	Check ignition timing.	Reduce timing in 2° increments, up to 8° from non-nitrous conditions.
	Inadequate octane fuel.		Use higher octane fuel; up to 116VPC-16
	Spark plug heat range too high.		Reduce spark plug heat range (max. 2 steps).
	Too much nitrous flow.		Reduce nitrous jetting.
Engine detonates heavily when system is activated.	Inadequate fuel delivery due to: Plugged fuel filter.	Inspect fuel filter.	Clean or replace fuel filter.
	Crimped fuel line.	Inspect fuel line.	Replace crimped line.
	Weak fuel pump.	Install fuel pressure gauge, such as NOS P/N 15931NOS. Run engine under load at wide-open throttle, with system activated.	Repair/replace fuel pump.
High-RPM misfire when system is activated.	Excessive spark plug gap.	Inspect spark plugs.	Set spark plug gap at 0.030 to 0.035"
	Weak ignition/ignition component failure.	Inspect components (plug wires, distributor cap, etc.)	Replace worn components.
Surges under acceleration when system is activated.	Inadequate supply of nitrous.	Check bottle weight.	Replace with a full bottle.
	Bottle mounted incorrectly.	Compare bottle position and orientation to instructions.	Mount or orient the bottle correctly.

Nitrous Oxide Accessories

NOS systems are calibrated for optimum performance with a bottle pressure of 950-1000 psi. Heater kits are pressure-controlled to keep the bottle near 975 psi to provide optimum performance. **Bottle Heater (P/N 14169NOS)** is available for 10 & 15 lb. bottles.

Insulating the bottle helps maintain pressure by keeping heat in the bottle when it's cold, or heat out when it's hot outside. The blankets are made of a rugged, easily cleaned Nylon outer shell with insulation. It's also an excellent "dress up" accessory and perfect for "covering" battle-scarred bottles. **Bottle Blanket (P/N 14165NOS)** is a 7" diameter blanket for the 10 lb. bottle.

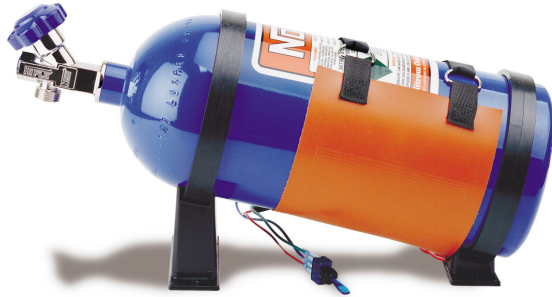

P/N 14169NOS



P/N 14165NOS



P/N 14168NOS

The **Remote Bottle Valve (P/N 14168NOS)** is the perfect convenience accessory—this opener allows you to open and close your nitrous bottle from the driver's compartment with the flip of a switch—no more trips to the trunk. The complete kit includes hardware and installation instructions.

The primary purpose of a **Purge Valve (P/N 16030NOS)** is to release trapped air or gaseous nitrous from the feed line(s). This helps to ensure consistent performance. And, purging looks cool too! We now have an **LED purge kit (P/N 16033NOS)**!



P/N 16030NOS



P/N 16033NOS

Nitrous Pressure Gauges (P/N 15910NOS) measure from 0-1500 psi (although recommended level is 900-950 psi) and are essential in monitoring the bottle.

The **Quick Release Hinged Aluminum Bracket (P/N 14140NOS)** is available for 10 lb. and 15 lb. bottles. **P/N 14147NOS** is available for the carbon fiber bottle.



P/N 15910NOS



P/N 14140NOS

For those who want the ultimate in appearance, NOS offers many popular bottles that are fully polished. **P/N 14745-PNOS** is our 10 lb. fully polished bottle.

For optimum weight reduction and distinctive high-tech looks, these DOT-approved NOS carbon fiber-wrapped bottles are it! Weighs about half of the standard bottle (empty). **P/N 14747NOS** has 12.5 lb. capacity.



P/N 14745-PNOS



P/N 14747-SNOS

NOS Technical Support
Toll-Free Phone: 1-866-GOHOLLEY
Phone: 1-270-781-9741
Fax: 1-270-781-9772

For online help, please refer to the Tech Service section of our website: www.holley.com

A5077-2-SNOS
Date: 08-11-09 JM