

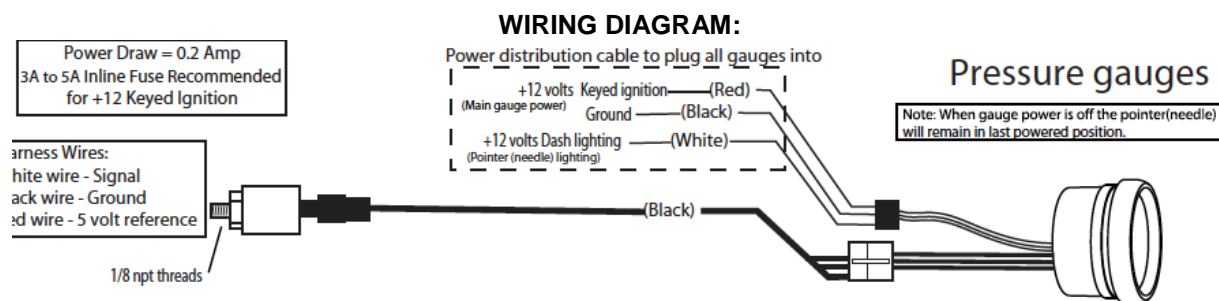

2-1/16" Gauge Instructions

	Black Gauge	White Gauge
Nitrous Pressure 0-1500 psi	15939NOS	15940NOS
Fuel Pressure 0-100 psi	15941NOS	15942NOS
Fuel Pressure 0-15 psi	15943NOS	15944NOS



INSTALLATION:

1. Disconnect negative (-) battery cable.
2. Connect wiring as listed above per style of gauge being installed.
3. Mount gauge for easy viewing. Use included spin lock ring to mount gauge. Snap white gauge connector to wiring harness.
4. Reconnect negative (-) battery cable and follow setting instructions below.

Setting warning LED for both low and high

LED can be set to turn on for both a low or high condition, or turned off in either/both case(s).

1. To enter LED calibration mode, Press and hold LED button with gauge power off. Turn on gauge power. Release button.
2. Needle will slowly scan clock-wise from min. low condition on dial. Press button at desired low warning set point. LED will blink to indicate low warning point has been set. Note: Pressing button at min. low (6 o'clock position) on dial will turn low LED warning so that it does not light up.
3. Needle will now travel to full high condition on dial and slowly scan counterclockwise. Press button at desired set point for high condition. LED will blink to indicate high warning has been set. Note: Pressing button at max high position on the dial will turn off high LED warning so that it does not light up.

To reset LED set point at any time follow this procedure again.

NOTE: Setting a low warning will turn on LED when needle travels below the low set point. Setting a high warning will turn on LED above the set point.

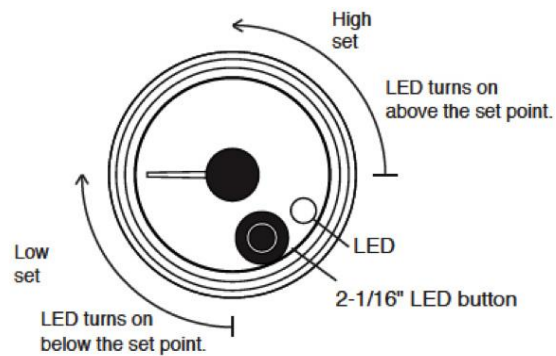

Setting LED brightness both day and night

1. With gauge power on press and release LED button (LED will light up at current brightness setting).
2. Press and release LED button to change LED to desired brightness setting--**5 settings options - off, 1, 2, 3, 4 (4 is brightest.)**
3. Do not press button for three seconds to save brightness setting. The LED will blink to indicate that setting has been saved.

NOTE: Setting the brightness setting when the gauge lighting is on will set the night-time brightness setting. Setting the level when the gauge lighting is off will set the daytime brightness setting.

Peak recall memory

Press and hold gauge button down and gauge needle will move between low and high peak. Gauge will continue toggling between low and high peaks as long as button is pressed.

NOTE: Low peak becomes active once gauge needle travels up at least 1/8 scale initially. Once this condition occurs, low peak becomes active and will record the lowest reading the gauge achieves.

To retain peak reading (NOT CLEAR IT)

While showing peak reading, release button, wait 5 seconds, gauge will return to normal and retain the peak reading.

To clear peak reading

While showing peak reading, release button, and immediately press and release again within 5 seconds. LED will flash 2 times and needle will travel to zero to indicate peak has been cleared.

NOTE: Fuel Pressure and Nitrous Pressure offers Dual Peak (Low/High) features.

Holley Technical Support: 1-866-464-6553

© 2018 Holley Performance Products. All Rights Reserved. Tous Droits Réservés.

199R11577

Date: 4-27-18