



COLD AIR INTAKE

INSTALLATION INSTRUCTIONS

D760-0035 Fits: 2013-16 F10 M5
D760-0037 Fits: 2013-18 F12/F13 M6

PARTS LIST

- | | |
|----------------------------|-------------------------------|
| (1) Left Carbon Airbox Lid | (1) Right Carbon Airbox Lid |
| (1) Left Carbon Snorkel | (1) Right Carbon Snorkel |
| (2) Air Filters | (2) Mass Air Flow Meter Tubes |
| (2) Filter Frames | (2) Rubber Boots |
| (1) Hardware Kit | |

Congratulations for being selective enough to use a Dinan Engineering Cold Air Intake. We have spent many hours developing this system to assure that you will receive maximum performance and durability with minimum difficulty in installation.

Please take the time to read these instructions thoroughly before proceeding. When performing the installation, read the entire numbered instruction before working on the car. If you feel that you do not have the requisite skill, please arrange for a qualified repair facility to perform the installation.

If you have any difficulties during the installation, or if these instructions are not clear to you, please call Dinan's Technical Support Staff at (800) 341-5480.

NOTE: Dinan toolkit #DT763-0083 is required for installation of this cold air intake. Contact your Dinan representative for details. However, if you already have toolkit DT763-0082 then you already have what you need.



INSTALLATION INSTRUCTIONS

Disassembly

1. Open hood and remove the rubber seal (1) covering the bolts and rivets by pulling it up out of its clips. See figure 1.

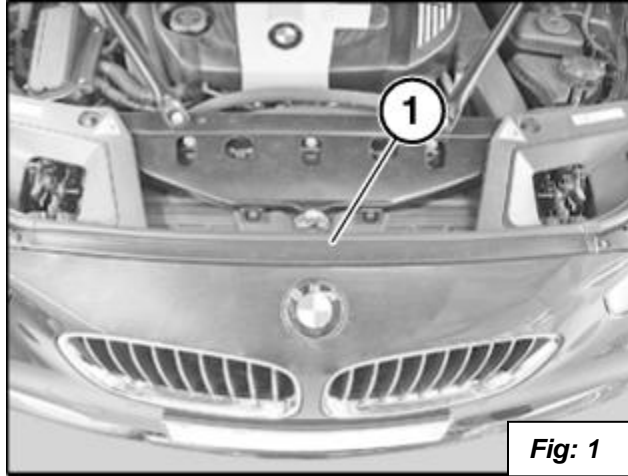

2. Remove the plastic side covers by removing the rubber engine seal and then lever out the expanding rivets (1) using BMW special tool 2 298 505. Remove cover (2). See figure 2.

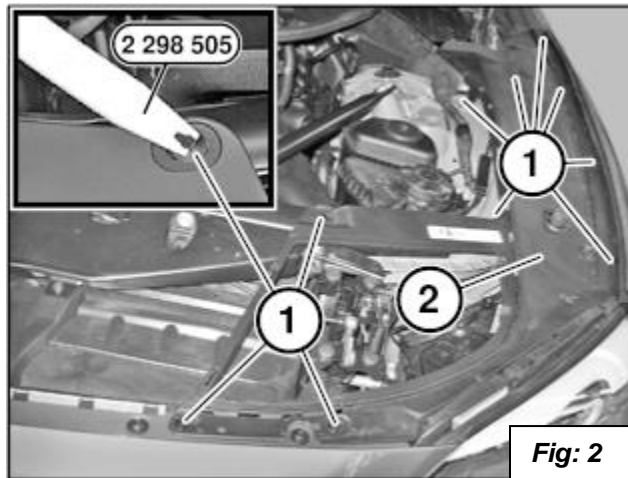

3. Remove the radiator support / cross brace assembly. Unscrew the bolts in positions (2), (3), (4) and (5). Leave the two braces (6) and (7) bolted together. See figure 3.

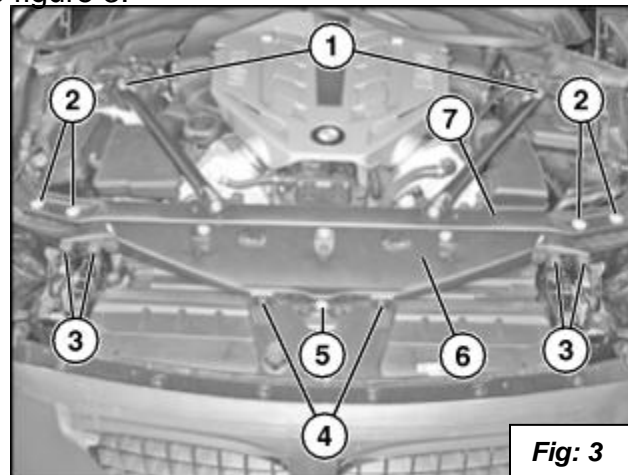

- Lift up the cross brace assembly slightly so you can unclip the cable (2) from the cross brace assembly (1). See figure 4.

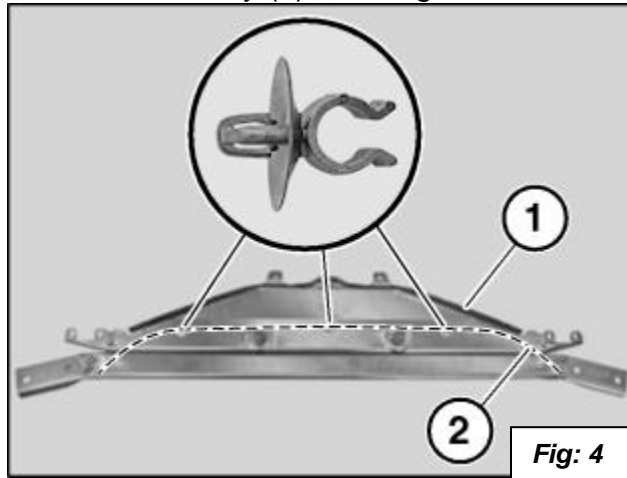

- Remove the front bumper. Unscrew all the bolts and screws at the top and bottom of the bumper panel as shown by the arrows in figure 5.

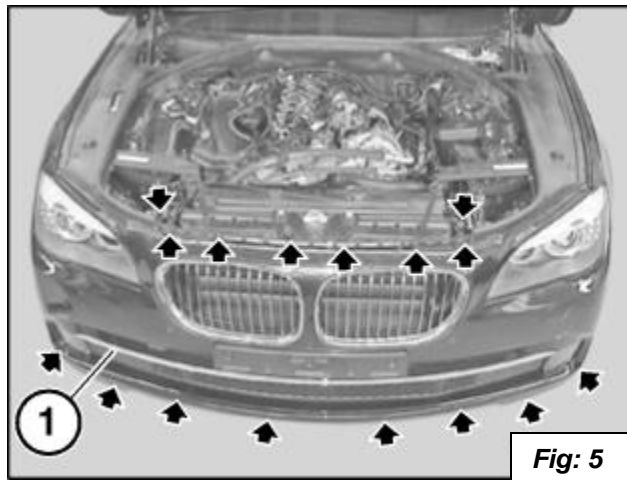

- Remove the screws (1) from the wheel arch inner fender then pull inner fender back so you can get too the two screws (2) holding the bumper to the fender. See figure 6.

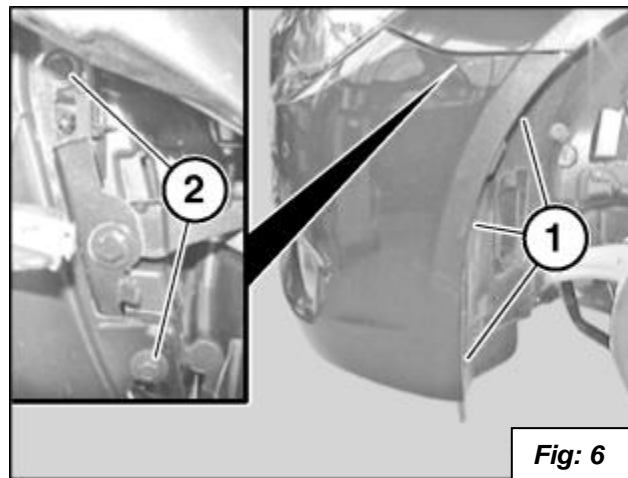

- This step is for cars with side view camera only.*

Unlock plug connection (3) from camera on both sides and disconnect. See figure 7.

Warning! Do not pull bumper out sideways -- Risk of damage.

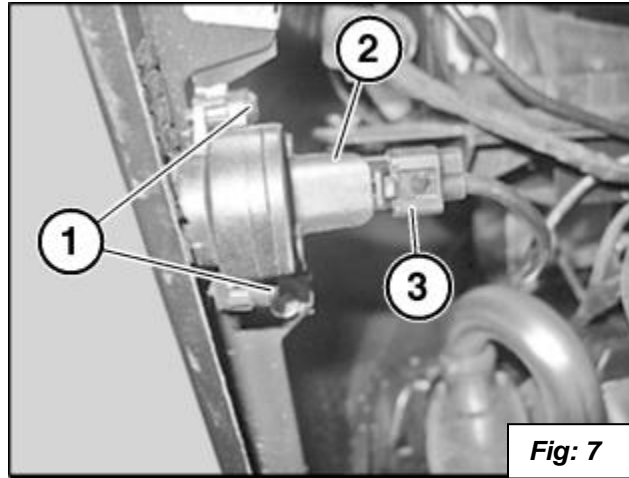

These two steps are for cars with night vision: Remove retaining screw (1) holding camera to shroud. See figure 8.

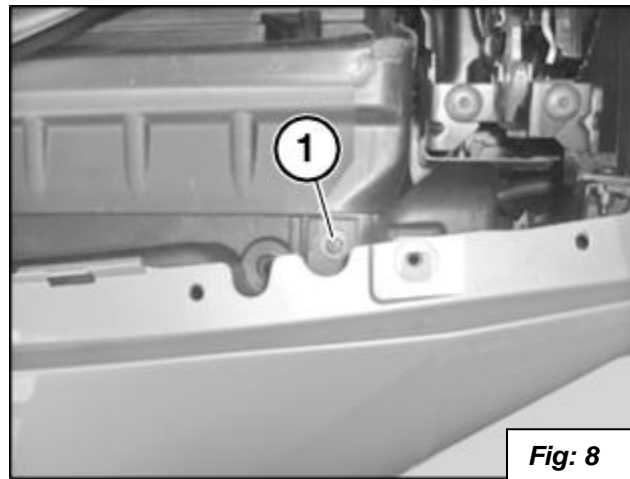

Release plug connection (2) and high pressure nozzle line (3) from night vision camera (1) and disconnect. See figure 9.

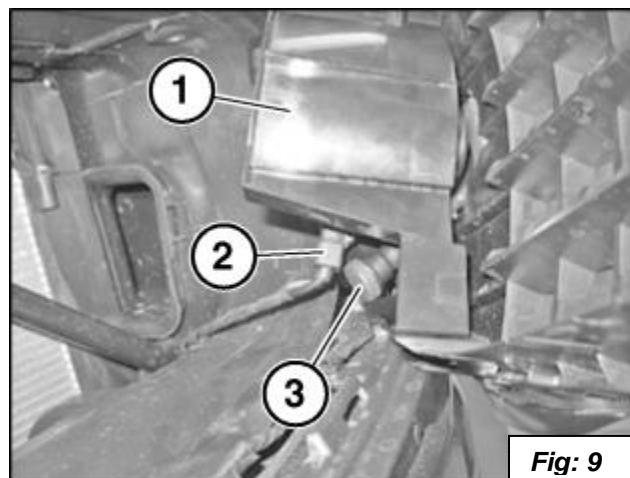

8. Remove bumper cover straight towards front with aid of a 2nd person.

Modify Parts – Air Filter Frame

9. The Air Filter Frames mount on top of the shroud in front of the radiator. You will cut two holes and mount the frames to the shroud. The Dinan carbon fiber snorkels screw to these frames. See figure 10.

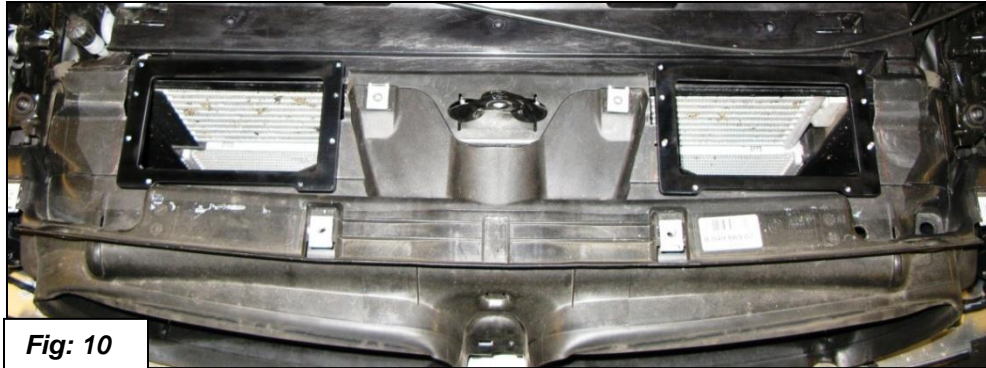

Fig: 10

10. Start by removing the outer air duct. Remove the two screws. Unlatch the five clips and remove the outer air duct. See figure 11. Slide out the air diffuser.

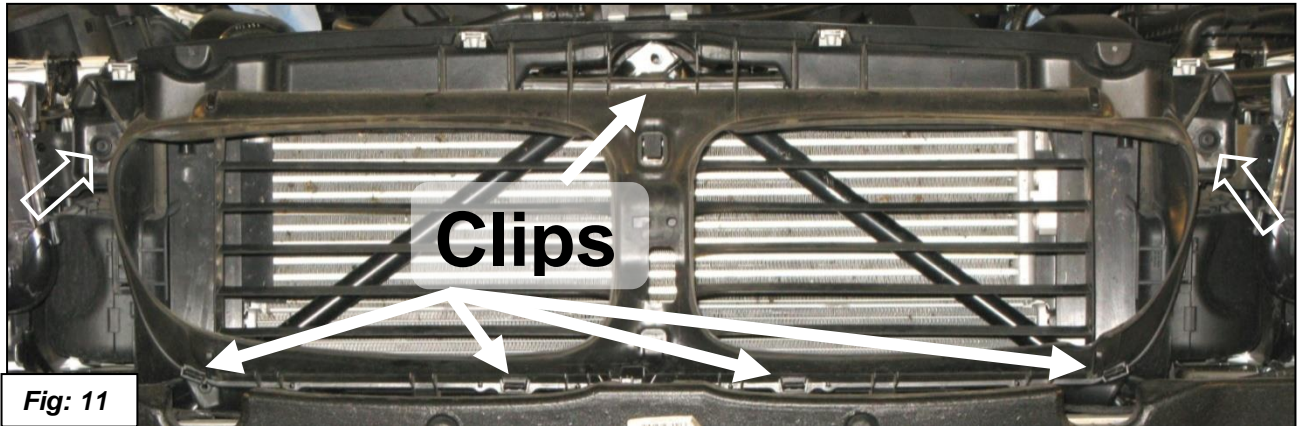

Fig: 11

11. Install the Air Filter Mount Template by inserting the mounting tabs into the two slots as shown. See figures 12 thru 14.



Fig: 12



Fig: 13

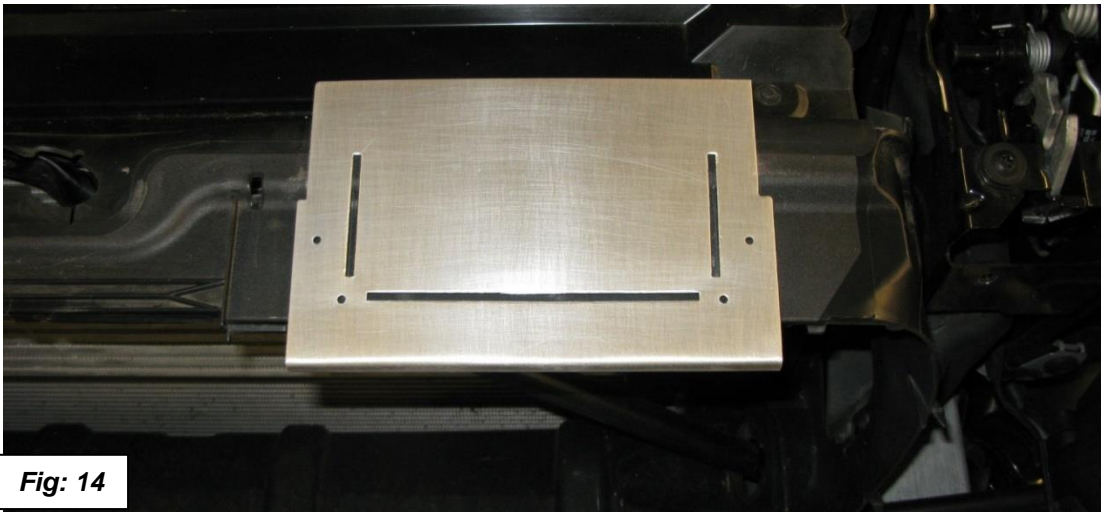

Fig: 14

12. Drill through the four holes in the template with a 1/8" drill bit. Scribe a line through the three slots of the template. See figures 14 and 15. Repeat on other side.

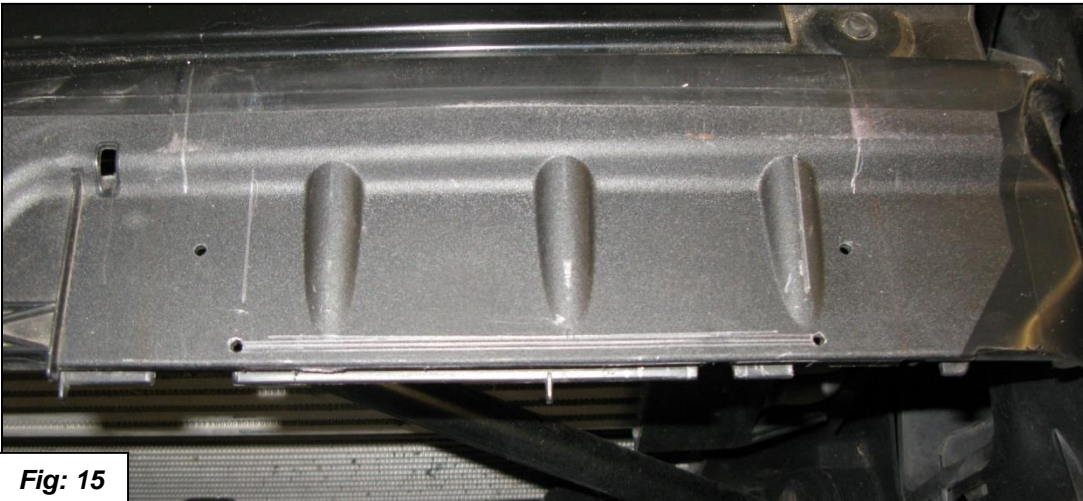

Fig: 15

13. Draw a line as shown in figure 16 to help you in cutting the hole for the Air Filter Mount. Repeat on other side.



Fig: 16

14. Cut out the holes for the Air Filter Mounts. Use aviation snips and a die grinder with a cut off wheel. First cut the back to front with aviation snips as shown in figure 17.



15. Mark the raised section on the outer side of each cut out as shown in figures 18 and 19. Cut out the rest of the holes with a die grinder with cut off wheel. Cut from side to side first then cut off the raised section. Drill out the mounting holes to 13/64". Deburr the edges of the plastic. See figures 18 thru 21.



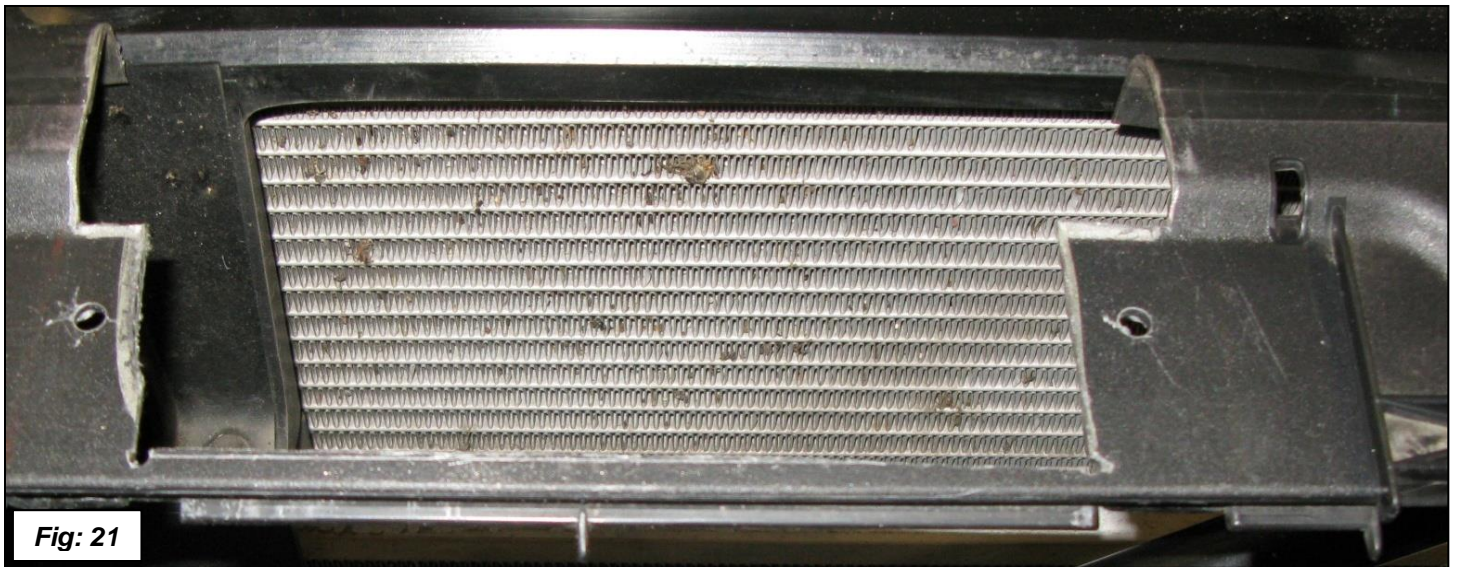

16. Install the air filter frames using the 4mm x 10mm screws and plastic washers. The frame rests on top of the shroud and gets bolted from the underside. See figures 22 and 23.



Modify Parts – Radiator Support / Joint

17. Trim the radiator support joint as shown in figures 24 thru 32. First: cut the front of the upper side. Scribe a line down 3/16" from the edge. Go from the flange to the half round notch. Cut away the metal with aviation snips or a die grinder with cut off wheel. File and sand smooth. Apply touch up paint to the cuts.

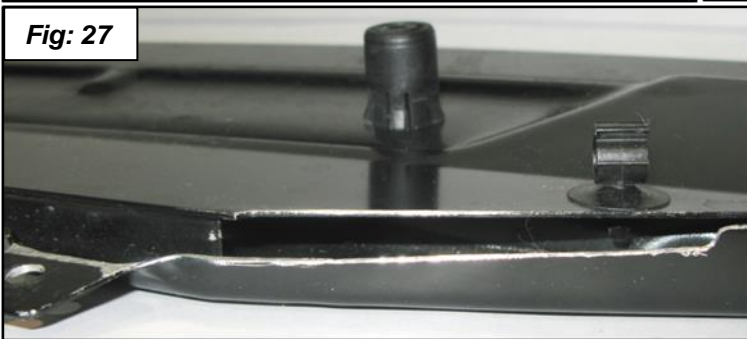
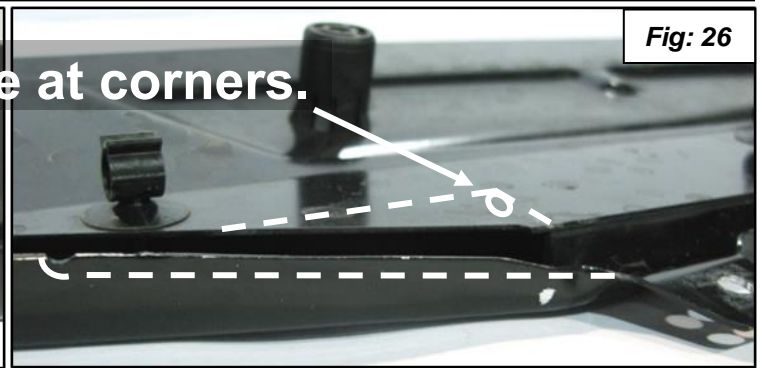
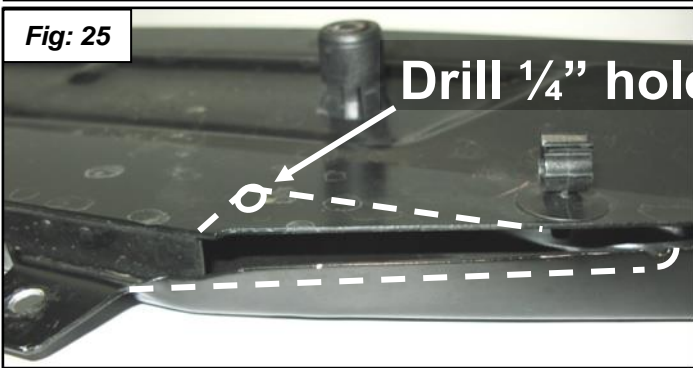

18. Second: cut a notch in the lower half. Scribe a line 90° from top edge $\frac{3}{4}$ " down, then scribe a line parallel to the top edge out to the notch in the upper half. Drill a $\frac{1}{4}$ " hole in the corner where the two lines intersect. Cut to the hole along the lines with aviation snips or a die grinder with cut off wheel. File and sand smooth. Apply touch up paint to the cuts.

Fig: 29

These lines parallel to edge down $\frac{3}{4}$ ".

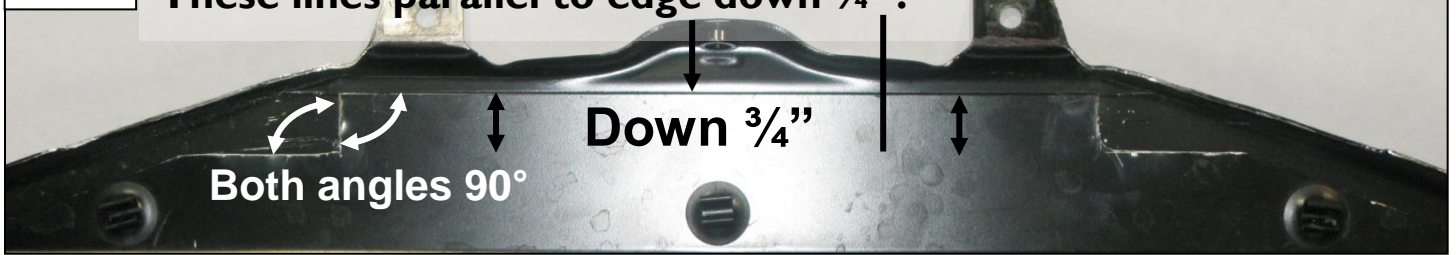

Assembly

19. Reassemble the air diffuser and outer air duct. Latch the five clips and install the two screws.
20. Install the radiator support joint in reverse order of removal. Leave the two screws out for now. See figure 33.
21. Install the bumper in reverse order of removal.

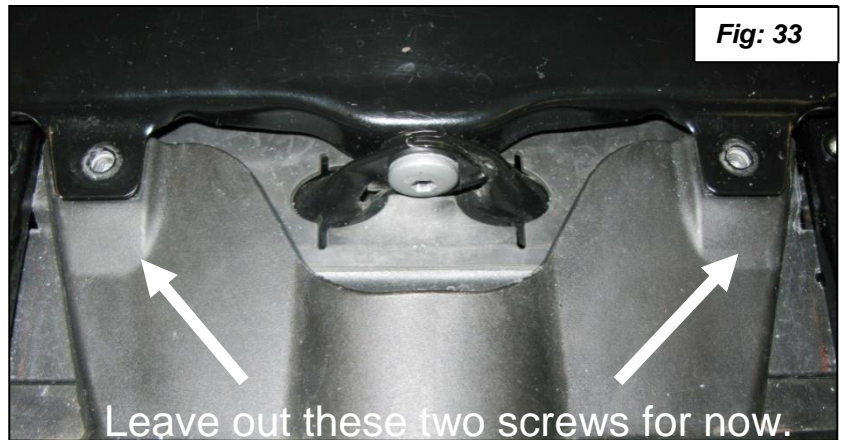

Removal of Air Boxes

22. Start with passenger side airbox. Remove fillister head screw with T25 Torx. See figure 34.



23. Disconnect MAF sensor connector (1) and loosen clamp (2). Pull boot off of MAF. Remove hose from clip (3). See figure 35.

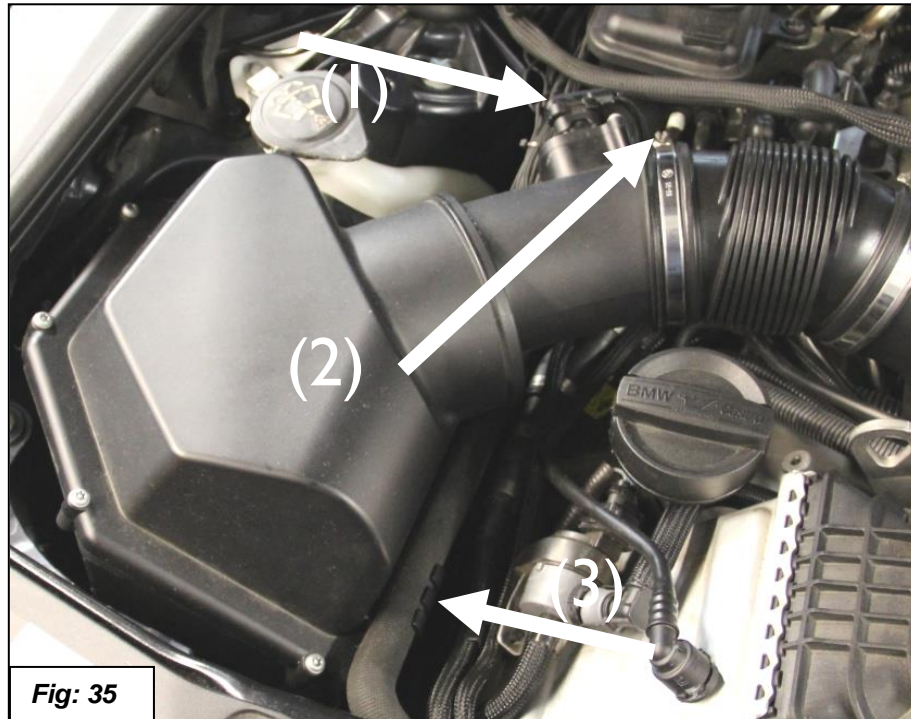

24. Pull tab toward the front of the car while gently pulling up on the front of the air box. This will release the air box from the track of the front boot. See figure 36.



25. Pull up on rear of air box to release ball joint. Air box should now be able to lift out of engine bay. See figure 37.

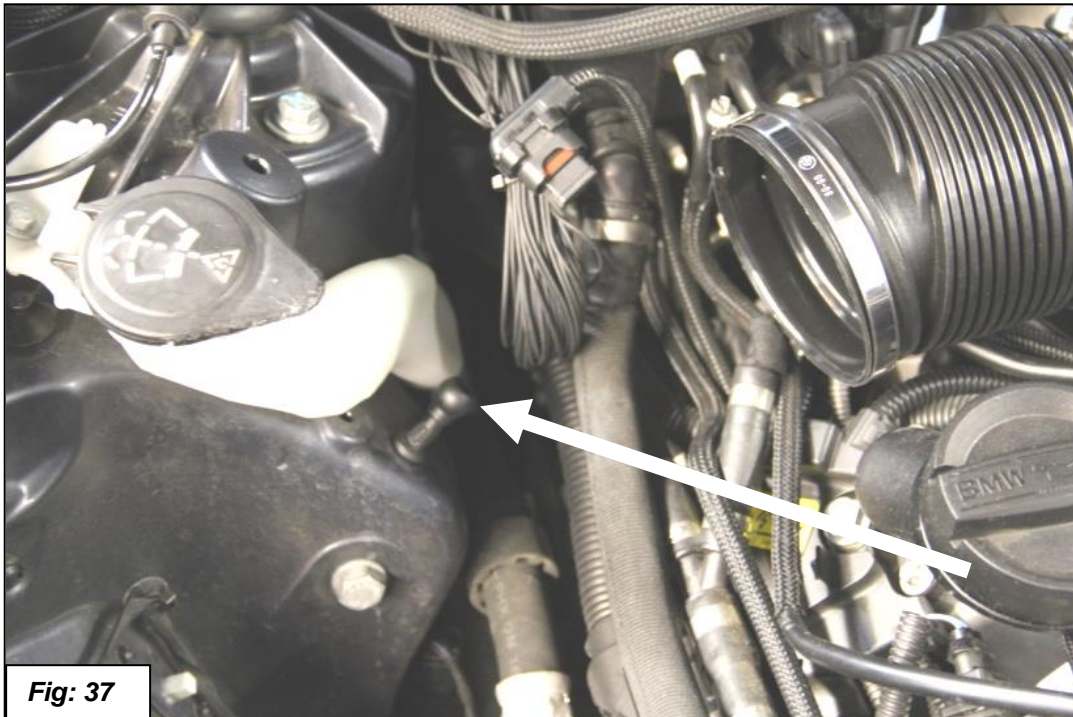

Fig: 37

26. Repeat steps in order to remove driver side air box. See figure 38.



Fig: 38

27. Steps 27 & 28 are the only steps that are unique to only the driver side air box. Remove bracket from figures 39 and 40 as shown. Use a T15 Torx for the single fillister head screw.

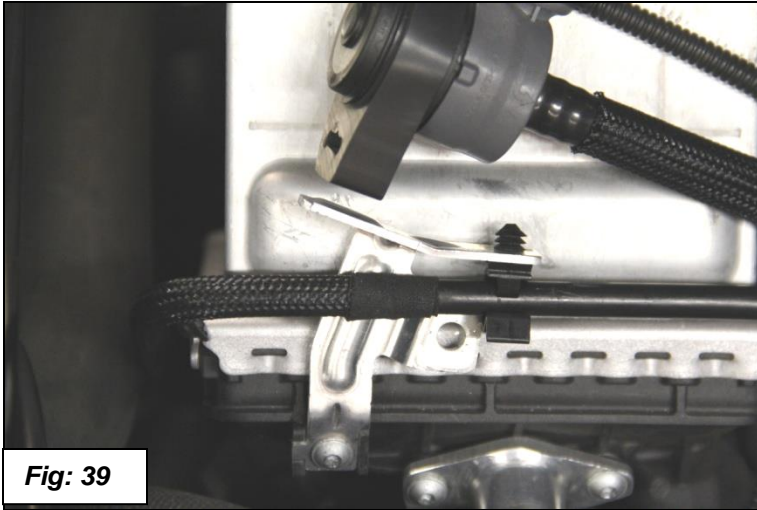

Fig: 39

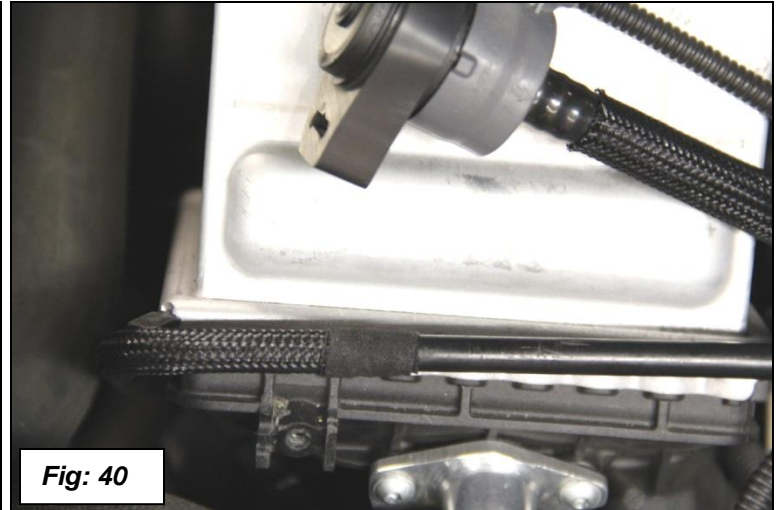

Fig: 40

28. Turn rubber bushing 90 degrees inward as shown in figure 41. Install Dinan bracket as shown in figure 42 using the same fillister head screw as the OEM bracket.



Fig: 41

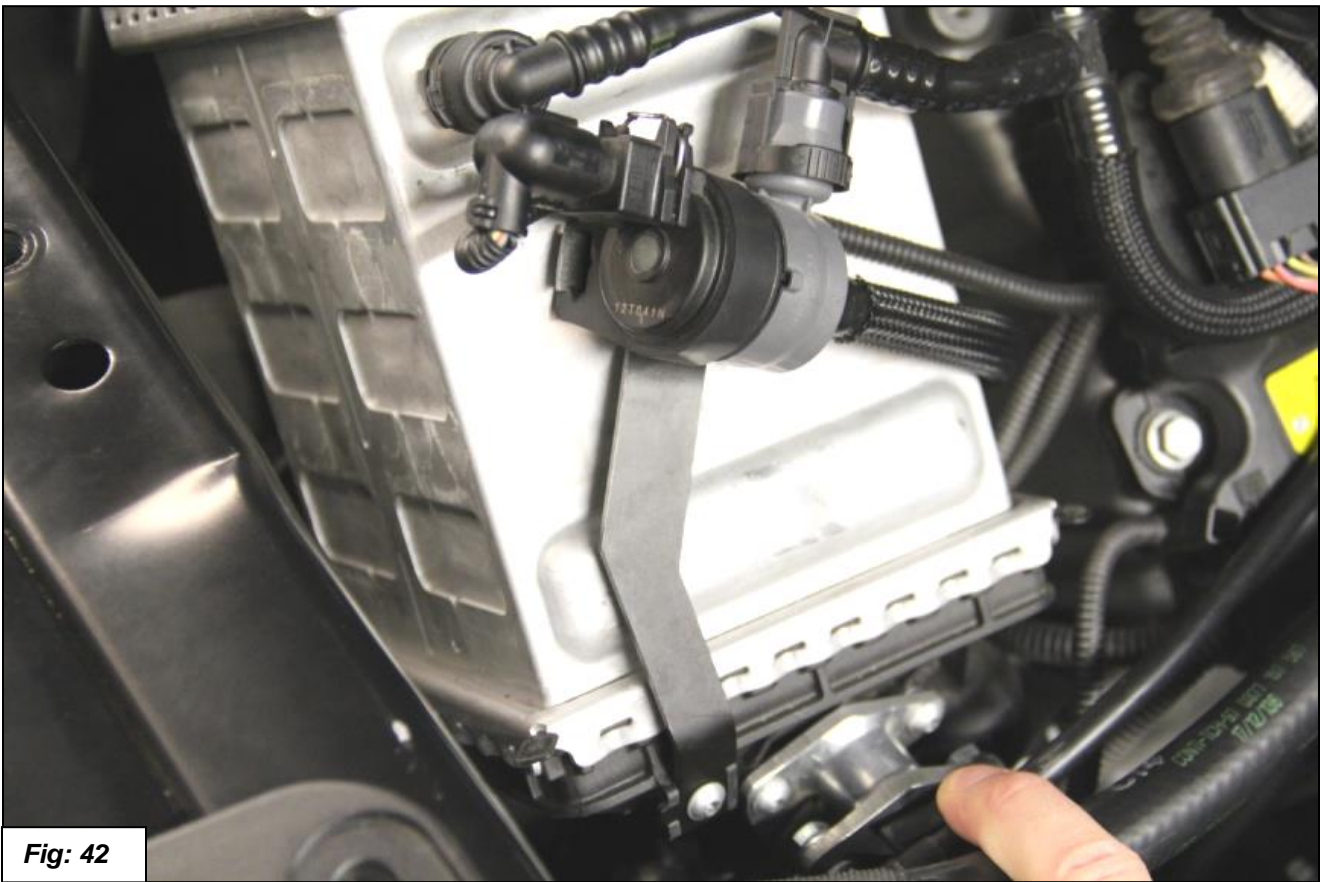

Fig: 42

29. Remove MAF sensors from MAF tubes using a T20 Torx. See figure 43.



Fig: 43

30. Remove fillister head screws that secure upper air box lid to lower air box with T25 Torx (7 screws). Remove upper air box lid. See figure 44.

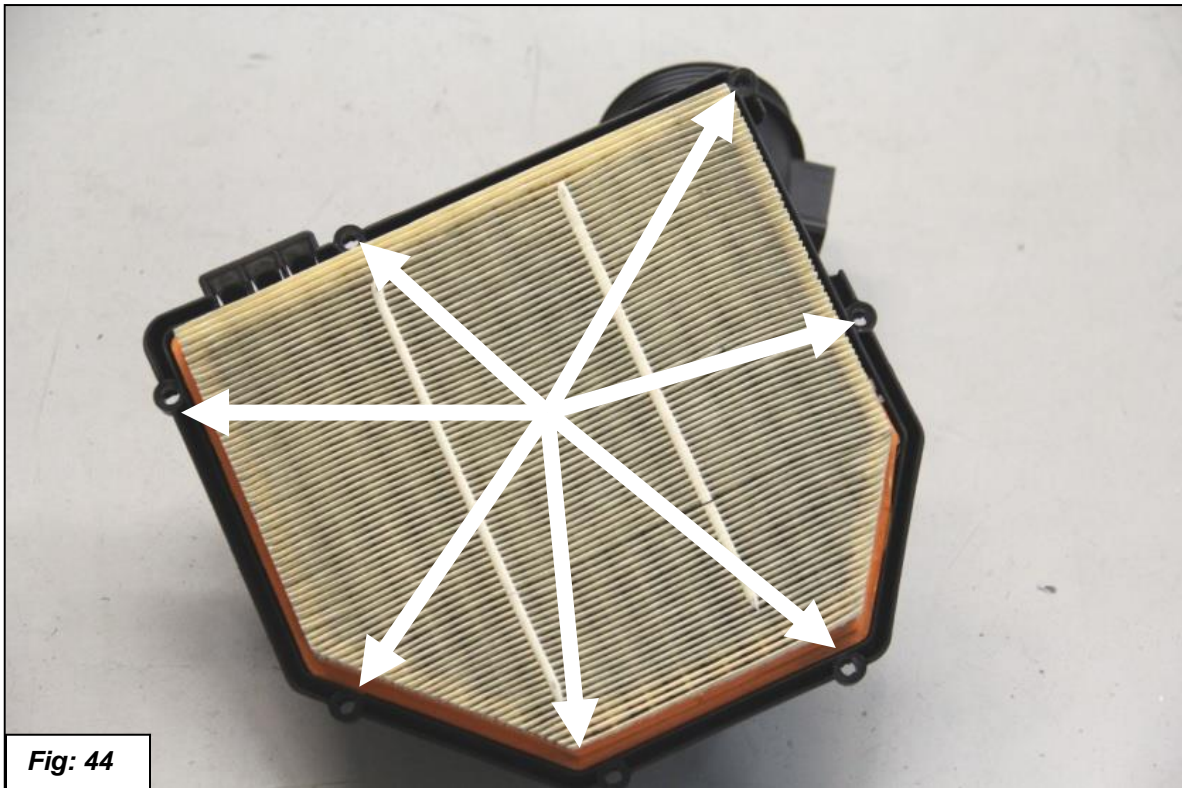

31. Clean out track in lower air box. See figure 45. Insert adhesive gasket into lower air box tack. Peel off adhesive backing paper before installing. Trim gasket as necessary to fit. See figure 46.



IMPORTANT!

If your airbox has either a hole or snorkel in the bottom, you will need to install the block off plates included in this kit. The block off plates are purposely made thin in order to be able to conform to the curved surface of the lower airbox. Install on the outside of the airbox. If your airbox already has the BMW plates, the Dinan plates will not be used



32. Insert spacers into Dinan carbon lid (7 spacers). Spacers should be flush with lid surface. See figure 47.

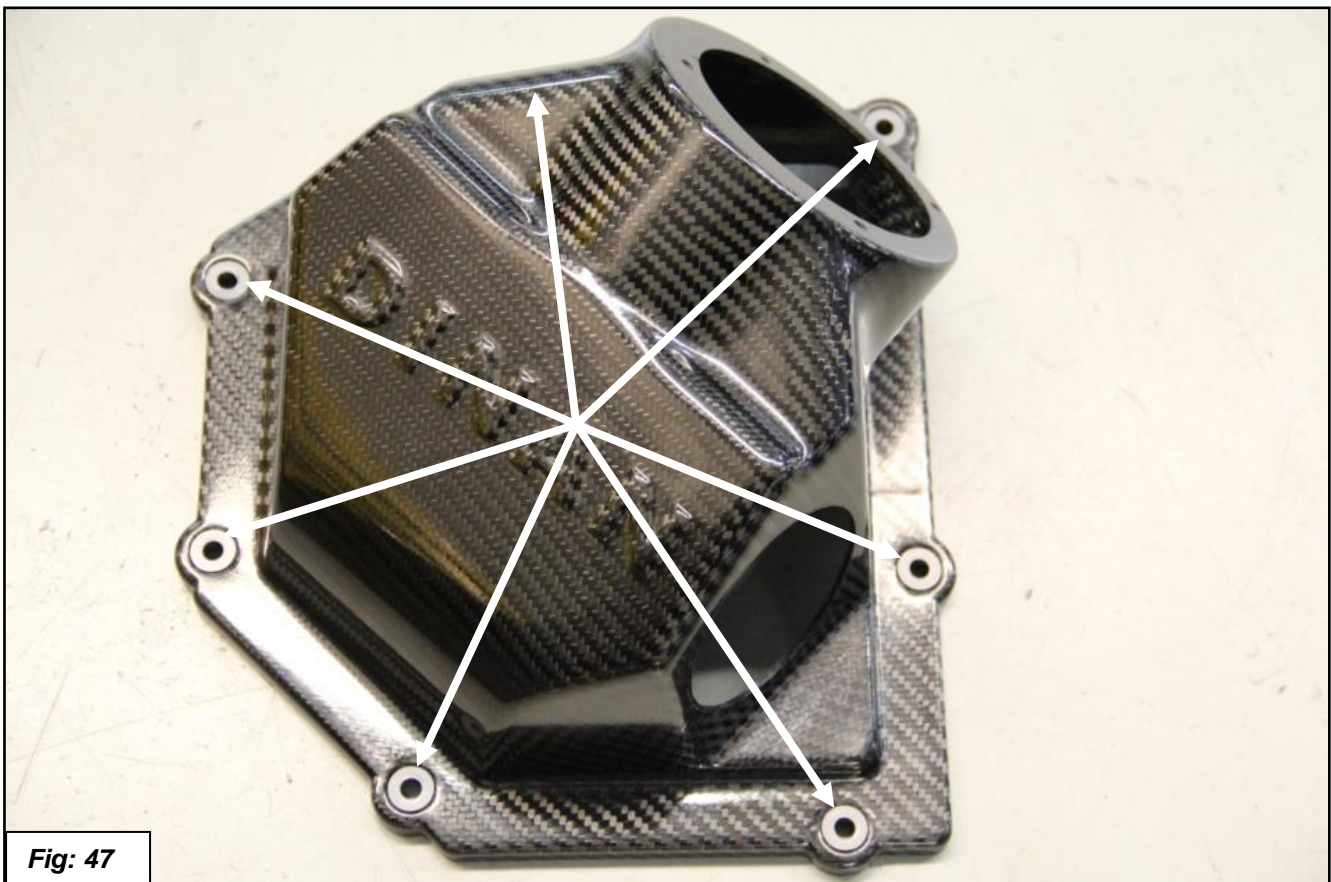
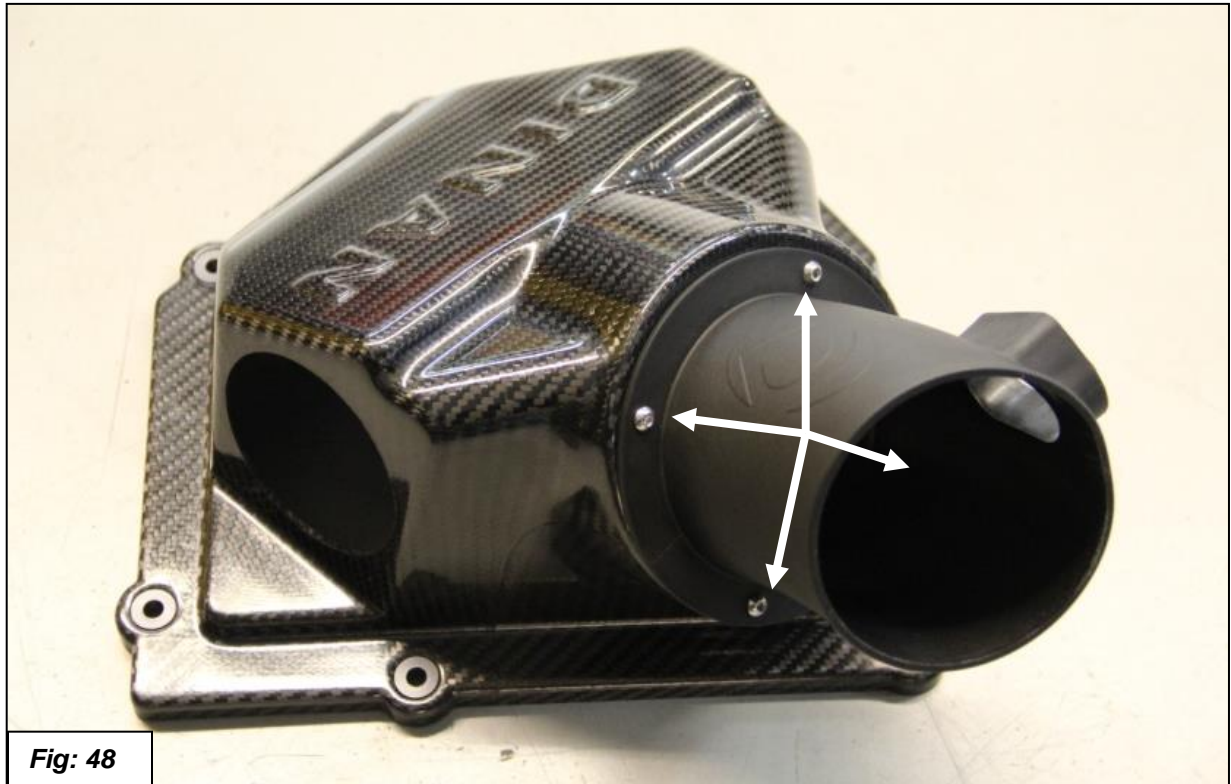
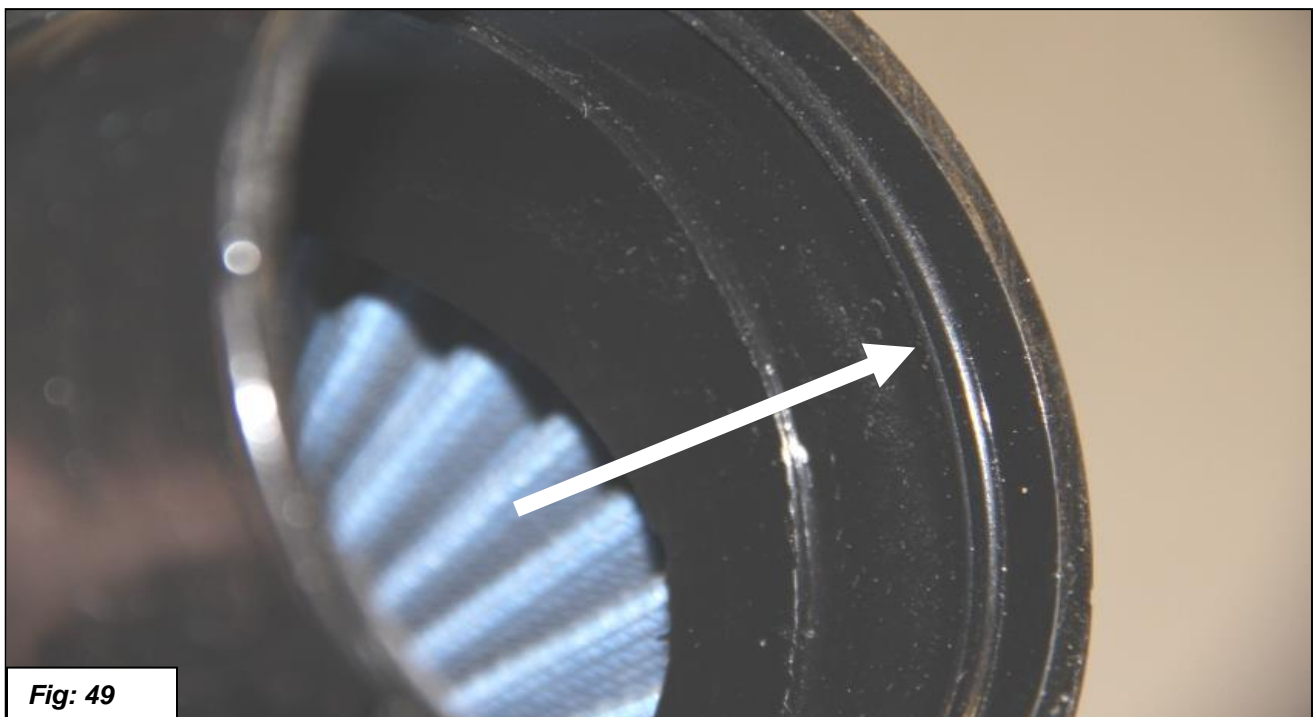

Fig: 47

33. Insert MAF into Dinan carbon lid. Secure with supplied M4x10 button head screws and tighten (4 screws). Bolt pattern only allows for one orientation. See figure 48.



34. Notice that the ridge on the inside of the filter matches the groove on the outside of the MAF. See figures 49 and 50.



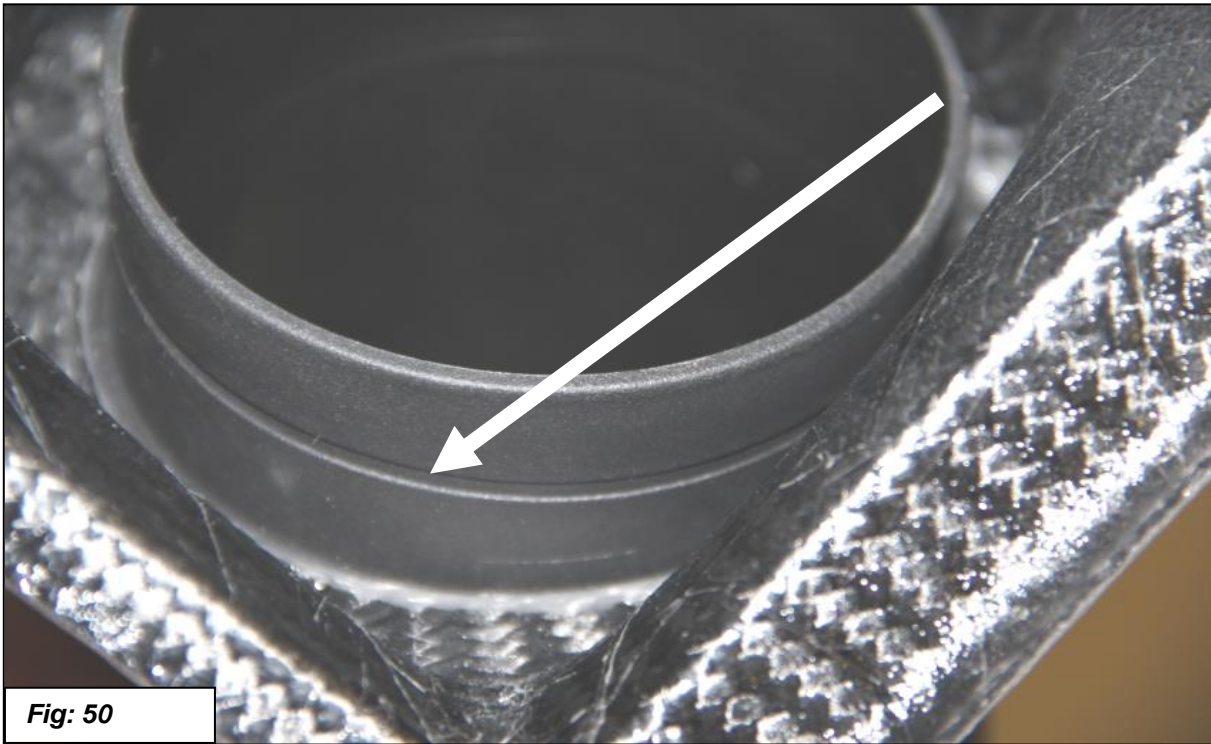

Fig: 50

35. Orient clamp in filter as shown. With clamp loosely fitted over filter base, slide filter onto MAF. Don't tighten clamp yet. See figures 51 and 52.



Fig: 51

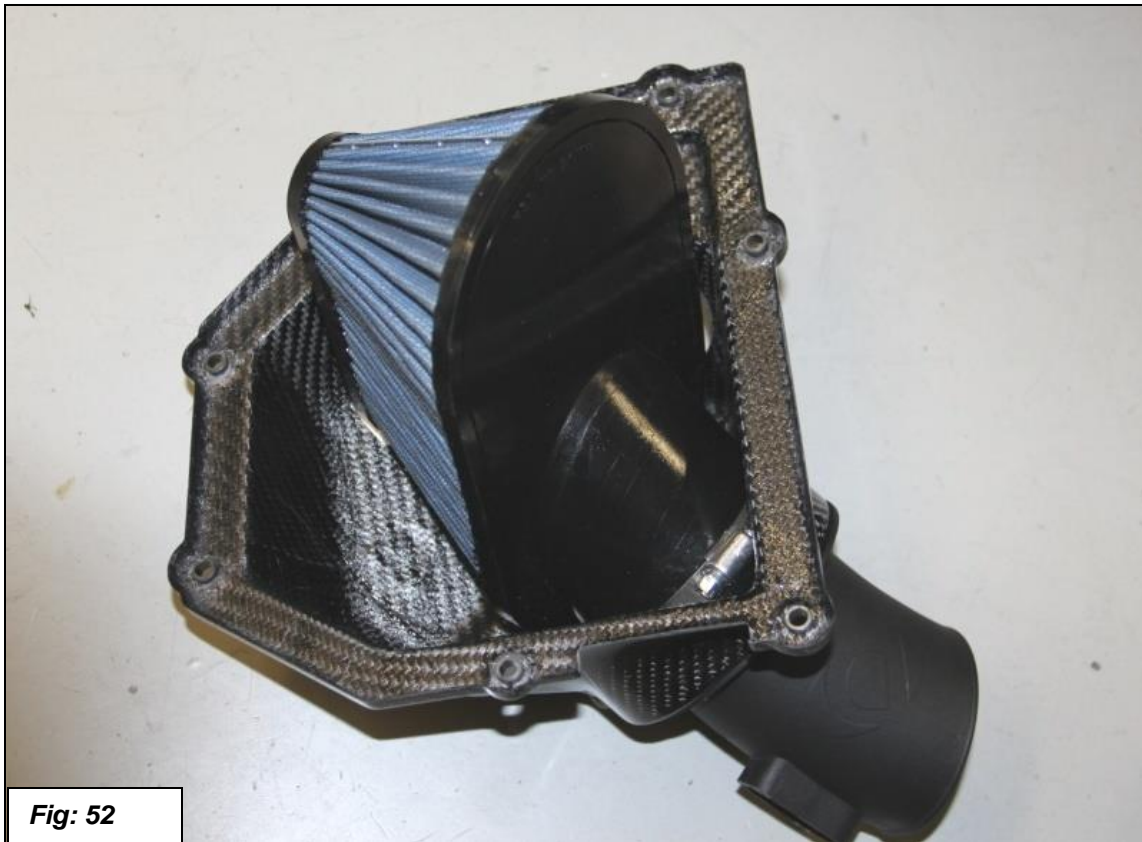

Fig: 52

36. Test fit upper air box lid on lower air box to make sure that the filter orientation is not causing misalignment between the air boxes. Rotate filter as necessary to clear lower air box. Once the correct orientation is found, tighten clamp with 8mm wrench. See figure 53.



Fig: 53

37. Install upper air box lid onto lower air box and secure with fillister head screws (6 screws). Leave the 7th screw out for now. See figure 54.



Fig: 54

38. Install MAF sensors into Dinan MAF tubes with the same fillister head screws that were in the OEM unit. The arrow on the sensor is the direction of airflow. See figure 55.



Fig: 55

39. Installation of the air box is the reverse of disassembly. A couple hints for making it easier -- make sure lower air box is sliding into the track on the front boot. See figures 56 and 57.

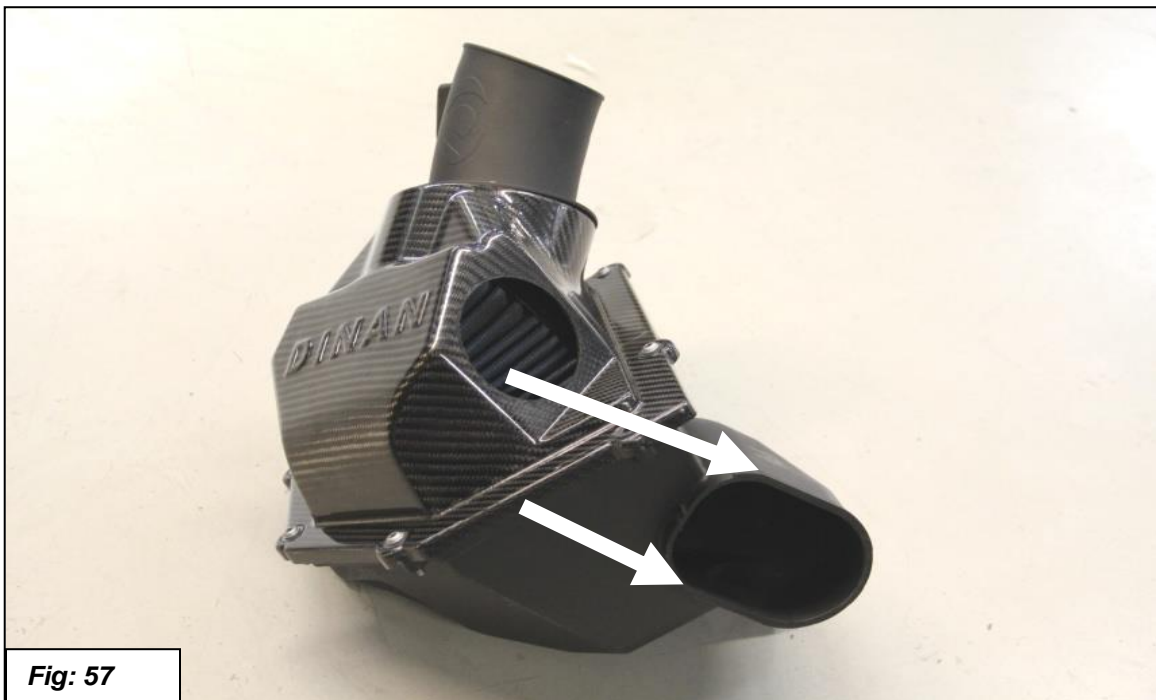
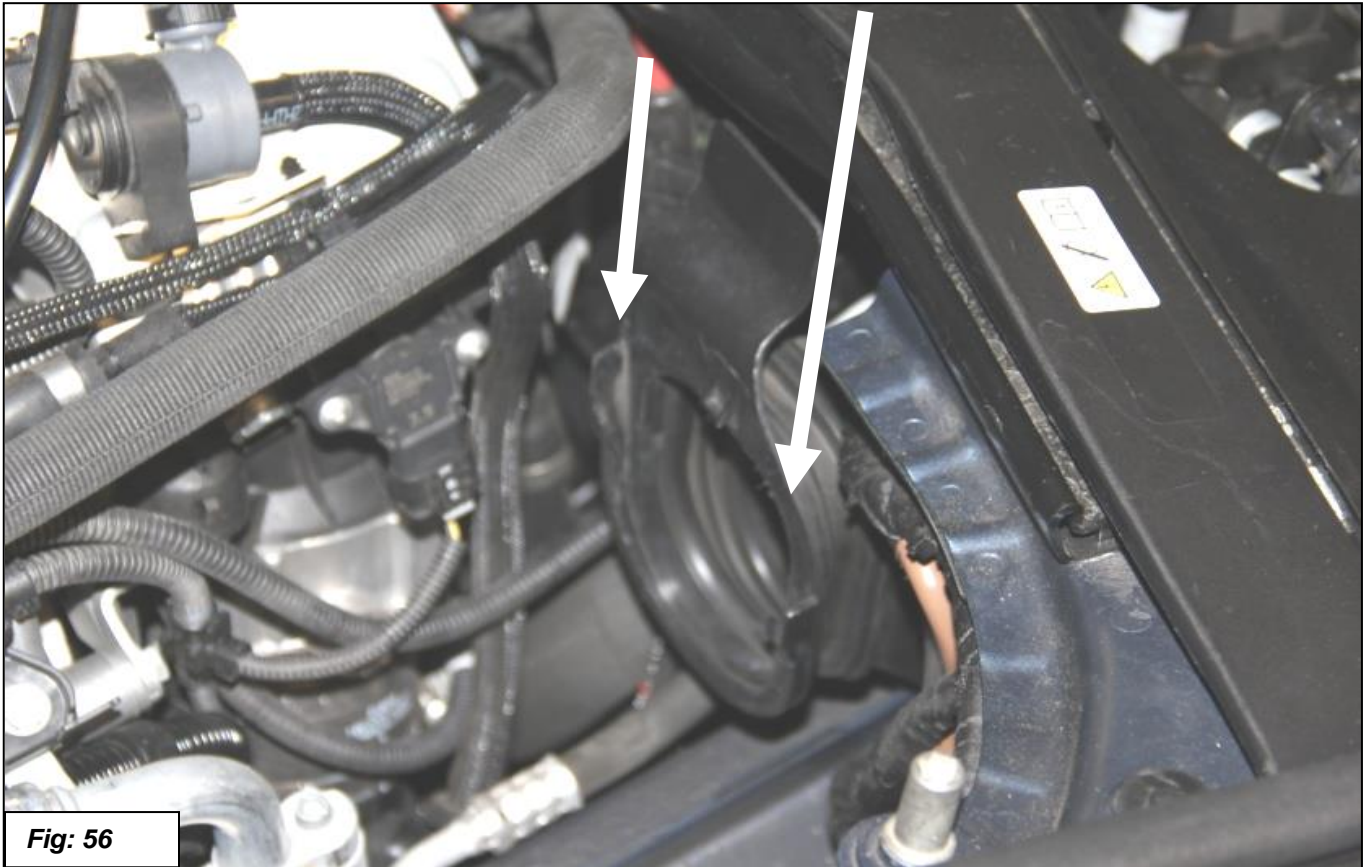

Also make sure this hose is out of the way as it can cause misalignment. See figure 58.



40. Install hose clamp as shown with 7th fillister head screw. See figure 59.

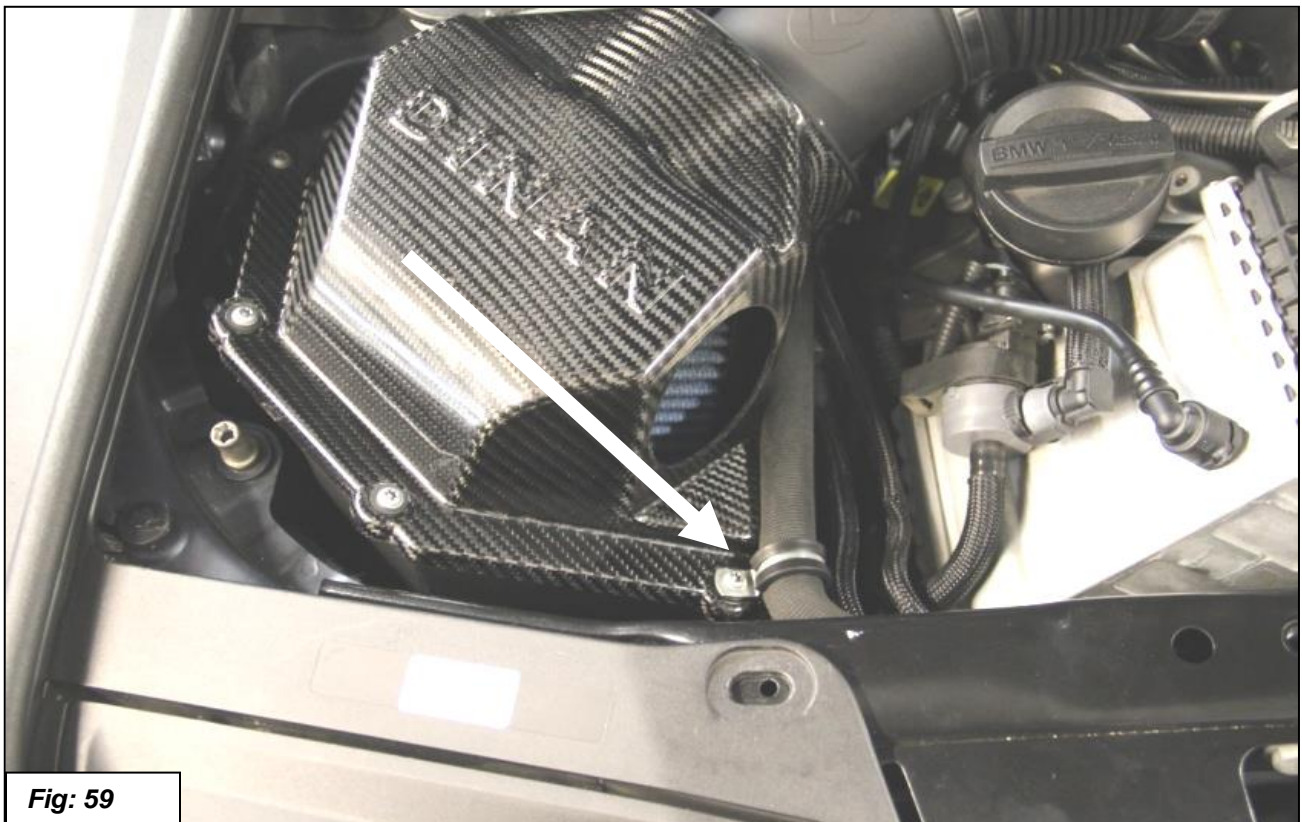

41. With the air box completely installed insert the Dinan snorkel as shown in figure 60. Then slide the base toward the center of the car as shown in figure 61. Make sure the bolt pattern of the snorkel lines up with the base plate and install the four M4x7 button head screws with black washers. See figure 62.



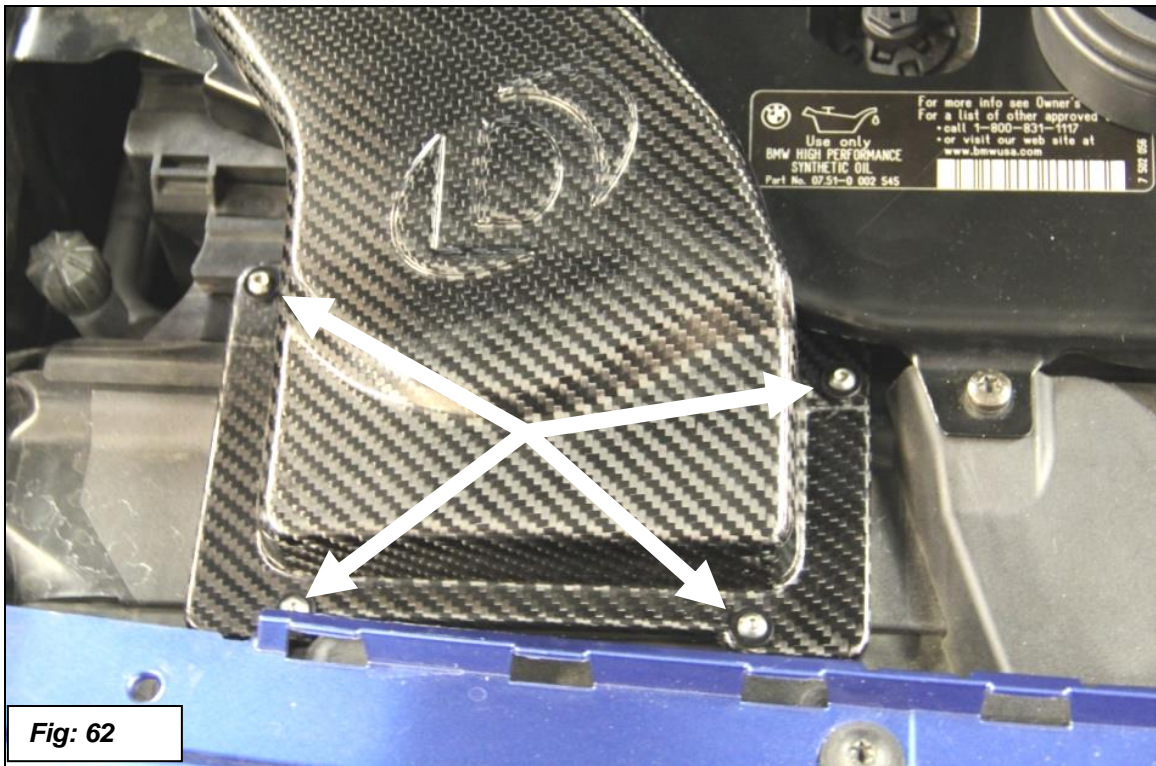
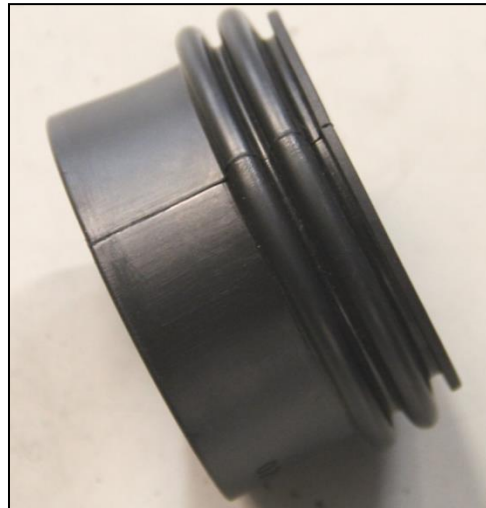
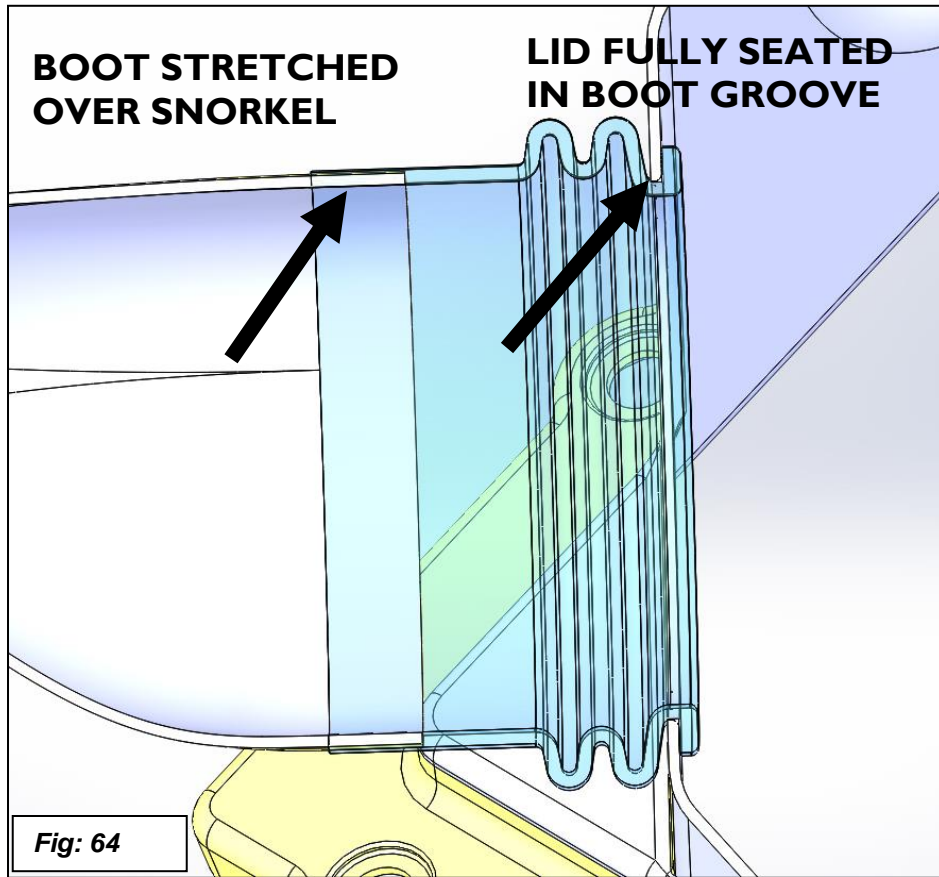

Fig: 62

42. Install the rubber boot that adapts the carbon snorkel to the carbon air box lid. Make sure that the grommet groove fully seats on the edge of the air box lid hole. The other end of the boot simply slides over the tube side of the snorkel. No clamps or hardware are necessary at these junctions. See figures 63-65.





43. Repeat install procedure on other side.
44. Reinstall the expanded rivets and weather stripping.
45. Plug in MAF sensor connector & tighten MAF boot clamp.
46. Double check all connections.
47. Installation is now complete.

PARTS LIST

<u>Qty</u>	<u>Part Number</u>	<u>Description</u>
1	D763-0149	Hardware Kit
12	D671-0147	M4 Button Head
8	D671-0151	M4 Button Head
12	D671-0163	Black Nylon Washer
2	D671-0163	Hose Clamp Mount
1	D762-0181	Ventilation Valve Bracket
14	D762-0185	Lid Spacer
2	D762-0188	Gasket 33"
