

INSTALLATION INSTRUCTIONS

MSD Pro-Billet Chevrolet HEI Distributor PN 83651, PN 8365/83653

ONLINE PRODUCT REGISTRATION: Register your MSD product online. Registering your product will help if there is ever a warranty issue with your product and helps the MSD R&D team create new products that you ask for! Go to www.msperformance.com/registration.

Important: Read these instructions before attempting the installation.

Parts Included:

1 - Pro-Billet Distributor	1 - Tube of Gear Lubricant
1 - Rotor, PN 84101	1 - Vacuum Advance Lock-Out
1 - Distributor Cap, Red PN 84111 or Black PN 84113	2 - O-rings
1 - Coil Cover, Red PN 84022 or Black PN 84024	1 - HEI Connector
1 - Digital HEAT Module, PN 83647	2 - HEI Wiring Terminals
1 - Coil, PN 8225	1 - HEI/Tach Connector
1 - Advance Kit	1 - Vacuum Advance Adjusting Kit
1 - Gasket	1 - Gray Tach Wire

WARNING: Before installing the MSD Distributor, disconnect the battery cables. When disconnecting the battery cables, always remove the Negative (-) cable first and install it last.

TIMING FUNCTIONS

Before continuing with the installation, here are a few definitions you should be aware of:

Initial Timing: This is the base timing (also referred to as idle timing) of the engine before the centrifugal advance begins.

Centrifugal Advance: The centrifugal (or mechanical) advance mechanism is made up of weights, springs and an advance stop bushing. The amount and rate of advance that your distributor is capable of is determined by the centrifugal timing. If you ever wish to lock out the centrifugal advance, refer to the centrifugal advance section.

Note: MSD Distributors are supplied with the heavy (slow) advance springs and the 21° stop bushing installed. This is to prevent detonation in certain applications. Review the information on pages 2-4 to determine the best advance curve for your application.

Total Timing: This is the total of the initial timing plus the centrifugal advance added together. Example: 10° Initial + 25° centrifugal = 35° Total Timing. (When checking Total timing, disconnect the vacuum canister and plug the vacuum source.)

Vacuum Advance: The vacuum advance will advance the timing up to 10° during partial throttle driving (with 15 lbs of vacuum). The vacuum line should be routed to a ported vacuum outlet above the throttle plates.

RPM LIMIT AND TACHOMETER INFORMATION

Tach Signal: The Pro-Billet HEI Distributor features a Gray Tach Output wire which provides a clean signal for most tachometers and even some aftermarket fuel injection systems. The signal output is a 12 volt square wave, 20° duty cycle. This wire is also responsible for programming the built-in rev limiter.

PROGRAMMING THE REV LIMIT

The rev limiter of the HEAT module requires a tachometer to set the rev limit. The limit is programmed by running the engine at half the desired rpm, then momentarily grounding the Gray tach output wire from the MSD. A Gray jumper wire is supplied to connect to the tach with another tee-splice coming off to use for programming. A switch may also be installed to ease adjustments of the limiter. The default rpm limit is 10,000 rpm.

CHOOSING AN ADVANCE CURVE

The function of the advance curve is to match the ignition timing to the burning rate of the fuel and speed (rpm) of the engine. Any factor that changes the burning rate of the fuel or the engine speed can cause a need for an ignition timing change. Figure 1 shows some of the factors that will affect engine timing.

FACTOR	Advance Timing	Retard Timing
	For	For
Cylinder Pressure	Low	High
Vacuum	High	Low
Energy of Ignition	Low	High
Fuel Octane	High	Low
Mixture (Air/Fuel)	Rich	Lean
Temperature	Cool	Hot
Combustion Chamber Shape	Open	Compact
Spark Plug Location	Offset	Center
Combustion Turbulence	Low	High
Load	Light	Heavy

Figure 1 Ignition Timing Factors.

As you can see from the chart, most factors will change throughout the range of the engine operation. The timing mechanism of the distributor must make timing changes based on these factors.

Example: An engine has 11:1 compression with a high energy ignition. With the specifications given, you will have to retard the timing for the high compression and high energy ignition. By comparing the engine's specifications against the chart, a usable timing guideline can be found. Engines with a combination of items from both columns will require a timing that is set in the mid range.

Obviously a full technical explanation of correct ignition timing would be very complicated. The best way to arrive at a suitable ignition curve for your engine is to use the Ignition Timing Factors Chart as a guide and compare it to the Advance Graphs in Figure 4 until a suitable curve is found. When selecting your advance curve, use detonation (engine ping) as an indicator of too much advance, and a decrease in power as an indicator of too little advance.

TIPS ON SELECTING AN ADVANCE CURVE

- Use as much initial advance as possible without encountering excessive starter load.
- Start the centrifugal advance just above the idle rpm.
- The starting point of the centrifugal advance curve is controlled by the installed length and tension of the spring.
- How quickly the centrifugal advance (slope) comes in is controlled by the spring stiffness. The stiffer the spring, the slower the advance curve.
- The amount of advance is controlled by the advance bushing. The bigger the bushing, the smaller the amount of advance.

CENTRIFUGAL ADVANCE CURVE

SELECTING THE ADVANCE SPRINGS

The rate, or how quick the advance comes in is determined by the type of springs which are installed on the distributor. The MSD distributors are equipped with two Heavy Silver springs installed. These will give you the slowest advance curve possible (Figure 2). The parts kit contains two additional sets

of springs which can be used to match the advance curve to your particular application. Refer to the Spring Combination Chart (Figure 3) for combinations that can be achieved.

To change the springs, remove the cap and rotor and use needlenose pliers to remove the springs. Be sure the new springs seat in the groove on the pin.

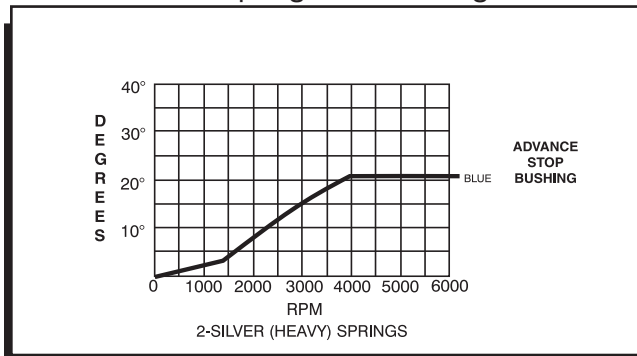

Figure 2 The Factory Equipped Curve.

SPRING COMBINATION	RATE OF ADVANCE	FIGURE 4
2- Heavy Silver		A
1- Heavy Silver		B
1- Light Blue		C
1-Heavy Silver		D
1-Light Silver		E
2- Light Blue		F
1- Light Silver		
1- Light Blue		
2- Light Silver	FASTEST	F

Figure 3 Spring Combination Chart.

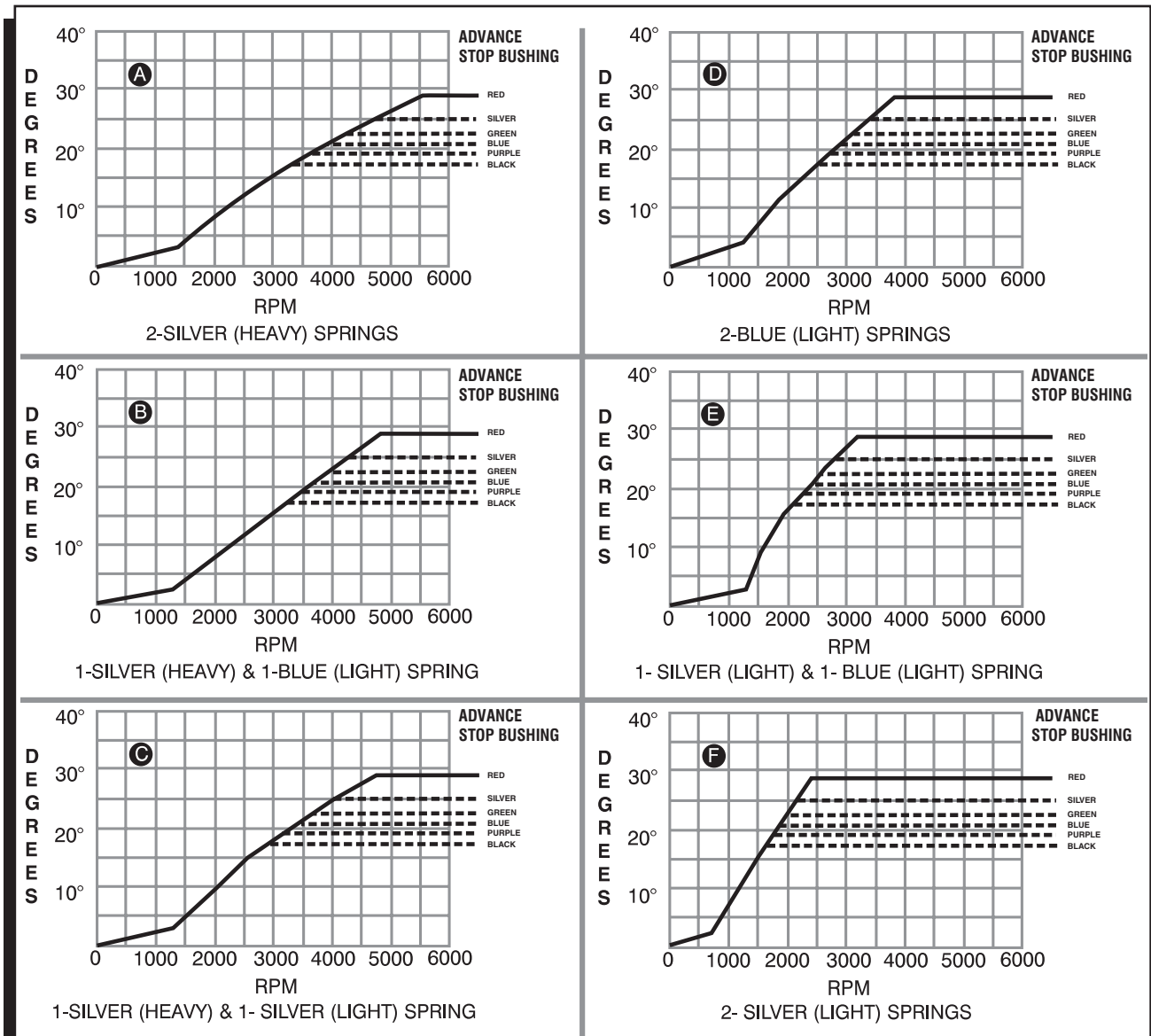

Figure 4 Advance Curves.

SELECTING THE ADVANCE STOP BUSHING

Five different advance stop bushings are supplied in the distributor kit. The distributor comes with a Blue (21°) bushing already installed. If a different amount of centrifugal advance is desired, follow the next procedure to change the bushings. The chart in Figure 5 gives the size and approximate degrees for the corresponding bushings.

BUSHING SIZE	APPROXIMATE CRANKSHAFT DEGREES
Red-Smallest	28
Silver	25
Green	23
Blue	21
Purple	19
Black-Largest	18

Figure 5 Advance Stop Bushing Chart.

CHANGING THE ADVANCE STOP BUSHINGS

1. Remove the distributor cap and rotor.
2. Remove the locknut and washer on the bottom of the advance assembly (Figure 6).
3. Remove the bushing and install the new one. Install the washer and locknut.

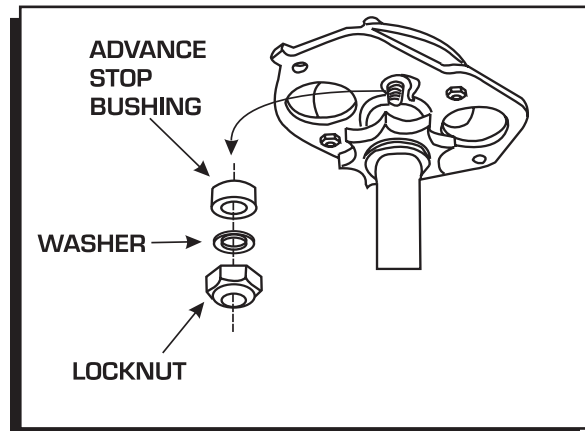

Figure 6 Changing the Advance Stop Bushing.

LOCKING OUT THE CENTRIFUGAL ADVANCE

1. Remove the advance components including the springs, weights and the advance stop bushing from the advance assembly.
2. Remove the roll-pin from the drive gear and remove the gear from the shaft.
3. Slide the shaft two inches out of the housing.
4. Rotate the shaft 180° and insert the advance stop bushing pin into the small hole on the advance plate (Figure 7).
5. Install the locknut and washer to the advance stop bushing pin. This locks the advance in place.
6. Install the drive gear and roll-pin.

Note: If you want to lock out the vacuum advance of the Distributor, see page 7.

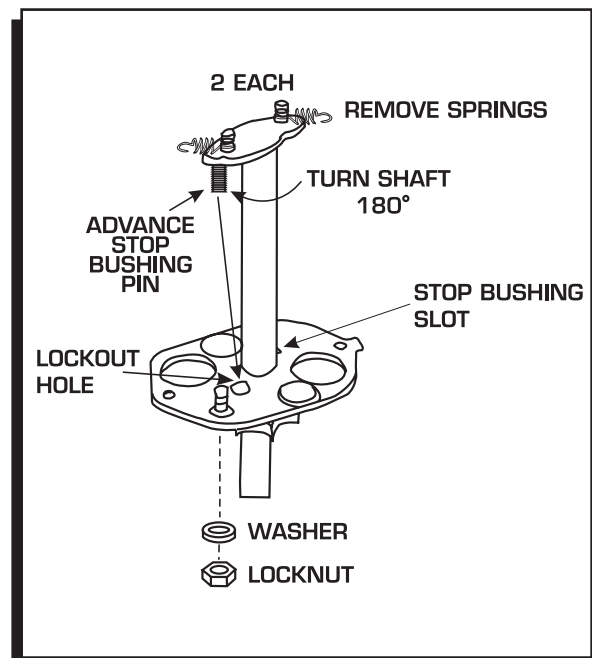

Figure 7 Locking Out the Advance.

INSTALLING THE DISTRIBUTOR

1. Remove the existing distributor cap without disconnecting any of the spark plug wires.
2. With the cap off, crank the engine until the rotor is aimed at a fixed point on the engine or firewall. Note this position by making a mark (Figure 8).
3. Place the distributor cap back on and note which plug wire the rotor is pointing to. **MARK THE SPARK PLUG WIRES** and remove the distributor cap.
4. Disconnect the wiring from the distributor.
5. Loosen the distributor hold down clamp and slide the clamp out of the way.
6. Lift the distributor out of the engine. Note that the rotor rotates as you lift the distributor out. This is due to the helical cut gear and should be taken into consideration when installing the new distributor.
7. Install the gasket and apply a liberal amount of the supplied lubricant to the distributor gear. (The supplied O-rings can **only** be used if the block has been modified as shown in Figure 9.)
8. Install the distributor making sure that the rotor comes to rest pointing at the same fixed mark. If the distributor will not fully seat with the rotor pointing to the marked position, you may need to rotate the oil pump shaft until the rotor lines up and the distributor fully seats.
9. Position and tighten the hold down clamp onto the distributor.
10. Install the distributor cap and spark plug wires one at a time to ensure correct location.
11. Connect a switched 14-gauge wire from a 12 volt source to the B+ terminal of the Distributor Cap (Figure 10).
12. Page 7 shows how to set the rev limiter and connect the tachometer.

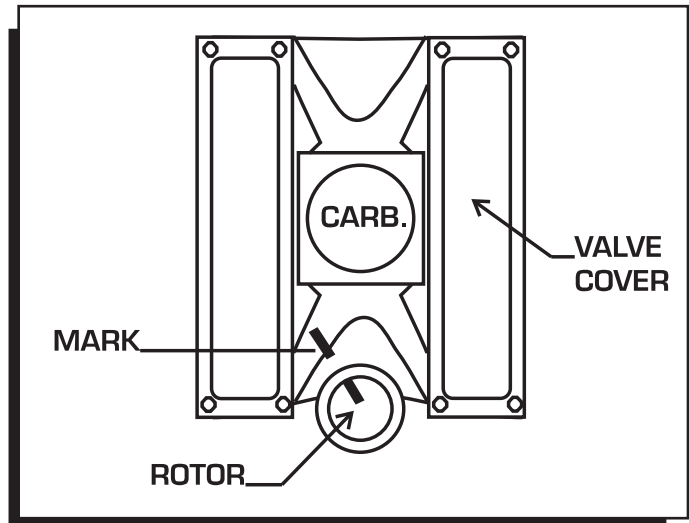

Figure 8 Marking the Rotor Location.

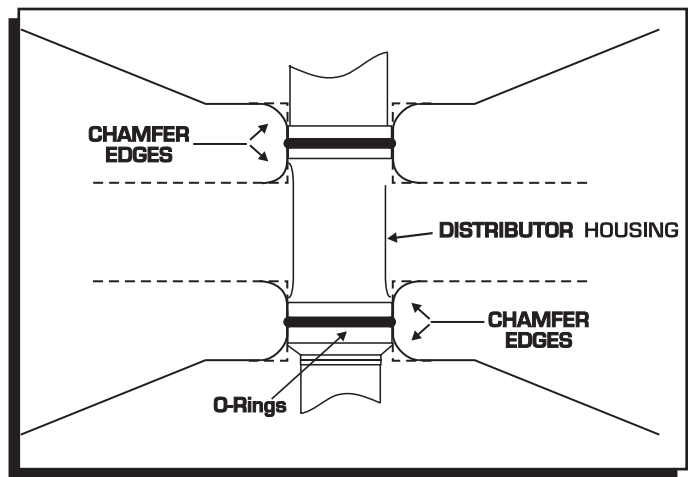

Figure 9 Modified Block for use with O-Rings.

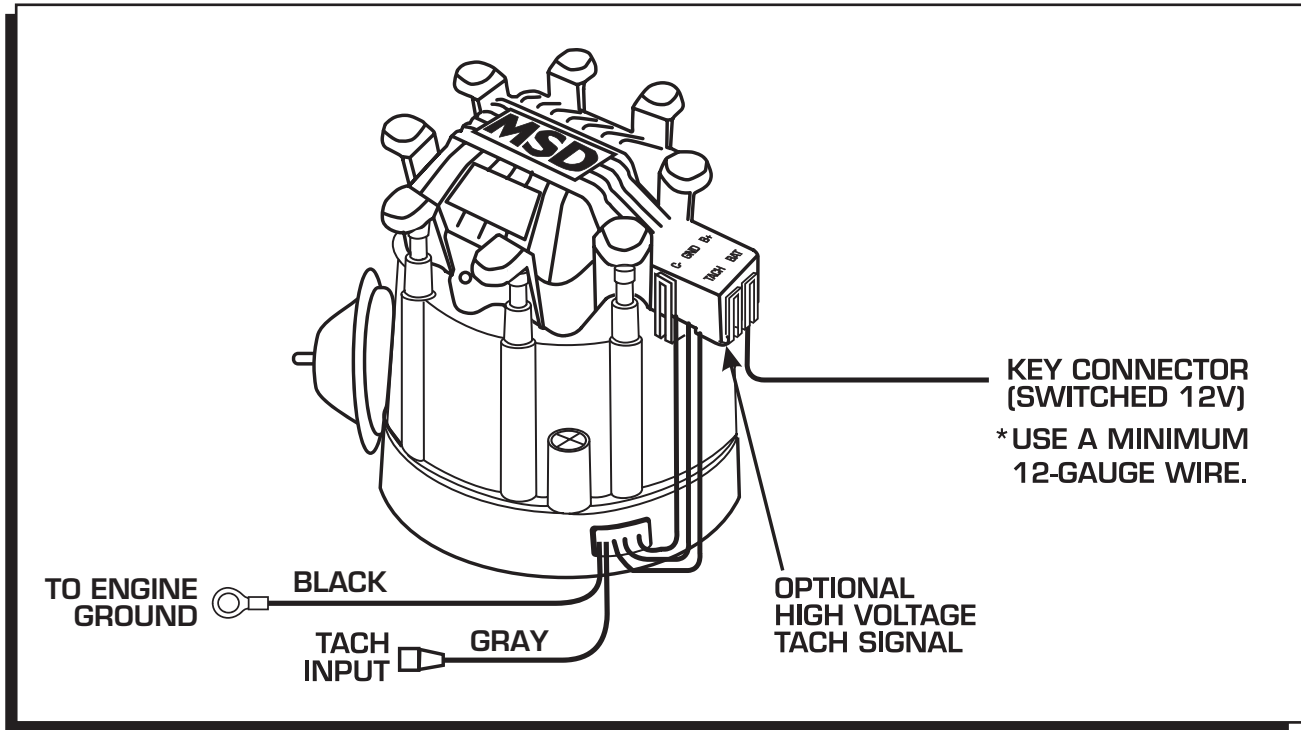

Figure 10 General Wire Installation.

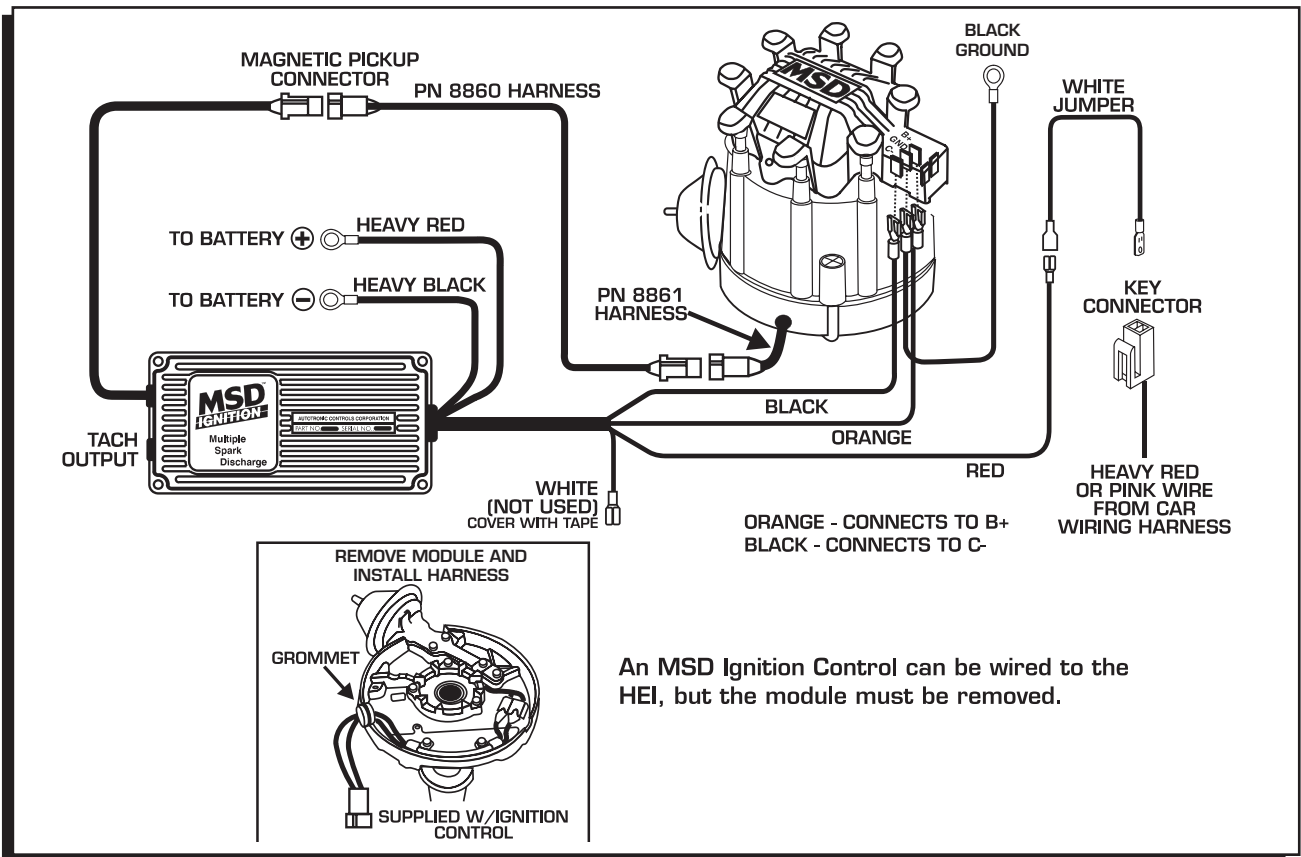

Figure 11 Wiring to an MSD Ignition Control.

VACUUM ADVANCE LOCKOUT

If you do not want to use the vacuum advance canister, MSD has supplied a lockout mechanism.

1. Remove the three Phillips screws that hold the advance canister (Figure 12).
2. Remove the aluminum hex shaped spacer from the housing.
3. Install the longer hex spacer supplied in the parts bag in the threaded hole next to where the original spacer was mounted. Use the same Phillips screw.
4. Install the plastic cover to seal the distributor housing using the original advance hold down screws (Figure 13).

Note: Do not forget to plug the original vacuum advance hose.

VACUUM ADVANCE ADJUSTMENT

A kit is supplied that allows you to adjust the total amount of vacuum advance.

TACHOMETER INFORMATION

The HEAT Digital HEI Module has a Gray wire that provides a 12 volt square wave, 20° tachometer signal that will trigger most tachometers. It is recommended to connect this lead to your tach's trigger input wire and check its operation. If the tach requires a higher voltage signal, connect its input wire to the Tach terminal on the HEI Cap (Coil-/Tach).

No Rev Limit: To disable the rev limit function, cut and remove the jumper shown in Figure 14.

PROGRAMMING THE REV LIMIT

A tachometer is required to set the rev limit. The limit is programmed by running the engine at half the desired rpm, then momentarily grounding the Gray tach output wire from the MSD. A Gray jumper wire is supplied to connect to the tach with another tee-splice coming off to use for programming. A switch may also be installed to ease adjustments of the limiter (Figure 15). The default rpm limit is 10,000 rpm. Note that the rpm limiter is extremely accurate and due to the variety of tachometers available, there may be differences in the displayed rpm.

1. Start the engine and bring the rpm to half the desired rev limit (for a 6,000 rpm limit, raise the rpm to 3,000).
2. While holding the rpm steady, short the Gray tach wire to ground for approximately one second. Note that the tach will go to zero while grounded.
3. The tach will now display the programmed rev limit amount for two seconds. If this value does not register on the tach, repeat the procedure and try a different ground source.

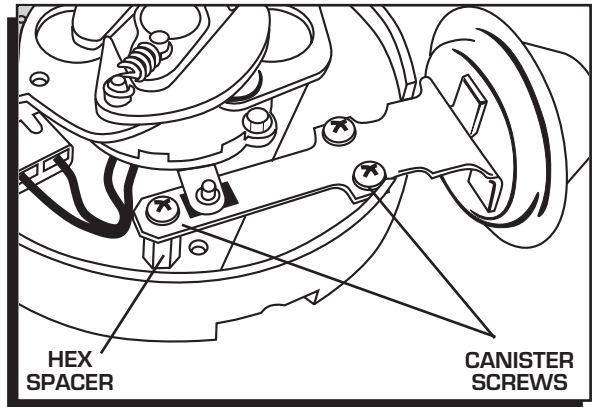

Figure 12 Removing the Vacuum Canister.

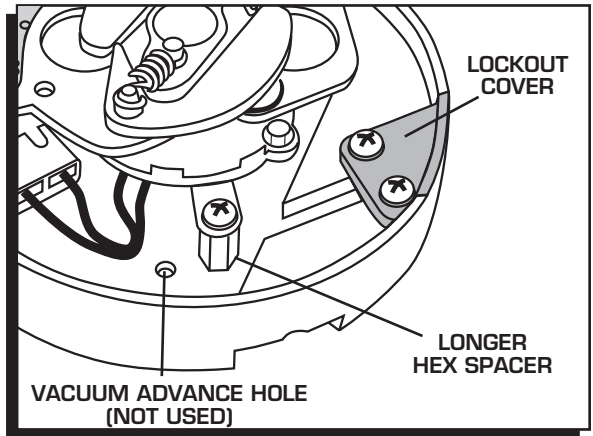

Figure 13 Vacuum Lockout Installed.

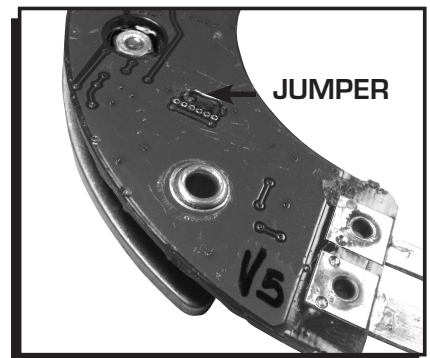

Figure 14 Disable the Rev Limit.

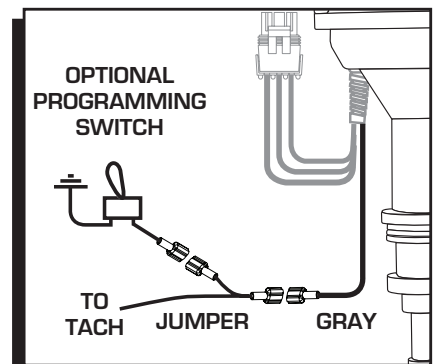

Figure 15 Setting the Rev Limiter.

INSTALLATION INSTRUCTIONS

Note: This rpm confirmation only displays when the HEI Gray wire is being used to trigger the tachometer.

REV LIMITER VERIFICATION

The MSD HEAT HEI Module has an optional built-in Rev Limiter Verification feature. When the key is in the On position (not cranking or running), an rpm signal is sent to the tachometer to verify the unit's rev limit setting. With this function users can be sure of their rev limit settings before each drive. To enable this feature, follow the procedure below.

Note: It is important to note that this feature should not be used with EFI systems. When activated, an rpm signal is sent to the tachometer. With an aftermarket EFI system, this could activate the injectors causing a flooding situation.

ENABLE REV LIMIT VERIFICATION

1. With the ignition switch in the off position, ground the Gray tach output wire.
2. With the Gray wire connected to ground, turn the ignition on without starting the engine.
3. Hold the Gray tach output wire to ground for seven seconds. (AT LEAST five seconds.)
4. Release the wire from ground before ten seconds have passed.
5. To confirm the process has worked, cycle turn the key On. The tachometer should sweep to the rpm limit set on the ignition.

To deactivate the verification feature, repeat the process.

Playback Tach: If you use a playback tach, be sure to check the high rpm value prior to turning the key to the On position. When the key is in the On position, the rev limit will be displayed and may override the tach memory.

Service

In case of malfunction, this MSD component will be repaired free of charge according to the terms of the warranty. When returning MSD components for warranty service, **Proof of Purchase** must be supplied for verification. After the warranty period has expired, repair service is based on a minimum and maximum fee.

All returns must have a Return Material Authorization (RMA) number issued to them before being returned. To obtain an RMA number please contact MSD Customer Service at 1 (888) MSD-7859 or visit our website at www.msdpower.com/rma to automatically obtain a number and shipping information.

When returning the unit for repair, leave all wires at the length in which you have them installed. Be sure to include a detailed account of any problems experienced, and what components and accessories are installed on the vehicle. The repaired unit will be returned as soon as possible using Ground shipping methods (ground shipping is covered by warranty). For more information, call MSD at (915) 855-7123. MSD technicians are available from 7:00 a.m. to 5:00 p.m. Monday - Friday (mountain time).

Limited Warranty

MSD warrants this product to be free from defects in material and workmanship under its intended normal use*, when properly installed and purchased from an authorized MSD dealer, for a period of one year from the date of the original purchase. This warranty is void for any products purchased through auction websites. If found to be defective as mentioned above, it will be repaired or replaced at the option of MSD. Any item that is covered under this warranty will be returned free of charge using Ground shipping methods.

This shall constitute the sole remedy of the purchaser and the sole liability of MSD. To the extent permitted by law, the foregoing is exclusive and in lieu of all other warranties or representation whether expressed or implied, including any implied warranty of merchantability or fitness. In no event shall MSD or its suppliers be liable for special or consequential damages.

*Intended normal use means that this item is being used as was originally intended and for the original application as sold by MSD. Any modifications to this item or if it is used on an application other than what MSD markets the product, the warranty will be void. It is the sole responsibility of the customer to determine that this item will work for the application they are intending. MSD will accept no liability for custom applications.