

MSD INSTALLATION INSTRUCTIONS

MSD Pro-Billet Cam Sync Chevrolet V8 Distributor PN 23451

Parts Included:

1 - Pro-Billet Distributor	2 - 1.5" Self Tapping Screws
1 - Rotor, PN 8421	1 - Gasket
1 - Distributor Cap, PN 8408	1 - Tube of Gear Lubricant
1 - Wire Retainer	2 - O-Rings

WARNING: When installing the MSD, disconnect the battery cables. When disconnecting, always remove the negative cable first and install it last.

Note: If the gear is ever replaced, MSD Gear (PN 8531) is required for replacement due to the .500" diameter shaft.

This distributor is equipped with an adjustable Hall-Effect Cam Sync Sensor for fuel injected engines. The Cam Sync can be adjusted to achieve the proper lead time required for the particular ECU being used.

The distributor also features an adjustable rotor. This allows the rotor phasing to be set properly and compensate for timing changes.

HALL-EFFECT PICKUP

LED OPERATION

The LED is On whenever the magnet is **not** in front of the pickup. The LED turns Off when the magnet passes over the center of the pickup (approximately 40°).

SPECIFICATIONS

Accepts 5 – 18 Volts continuous

Output: Within 1.5 volt on the red wire and .3 volt above ground.

Protected from reverse polarity, short circuit and over voltage.

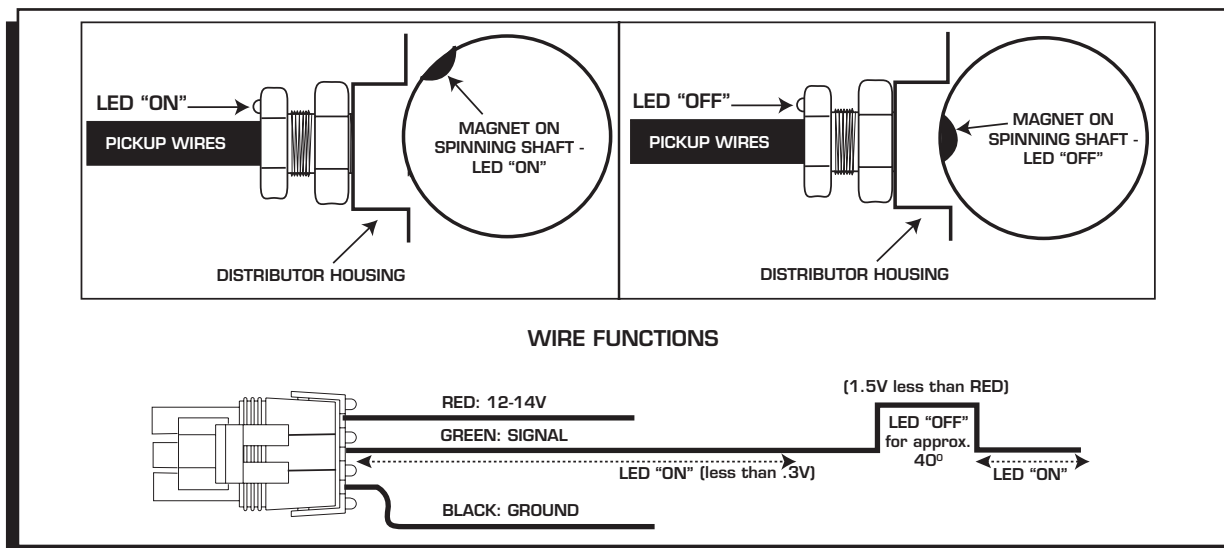

Figure 1 Installing the Hall-Effect Pickup.

INSTALLING THE DISTRIBUTOR

1. Position the engine at your desired timing. Remove the existing distributor cap without disconnecting any of the spark plug wires.
2. Install the gasket and apply a liberal amount of the supplied lubricant to the distributor gear. (The supplied O-rings can **only** be used if the block has been modified as shown in Figure 3.)
3. Install the distributor making sure that the rotor comes to rest pointing at what will be the number one cylinder. If the distributor will not fully seat with the rotor pointing to the marked position, you may need to rotate the oil pump shaft until the rotor lines up and the distributor fully seats.
4. Position and tighten the hold down clamp onto the distributor.

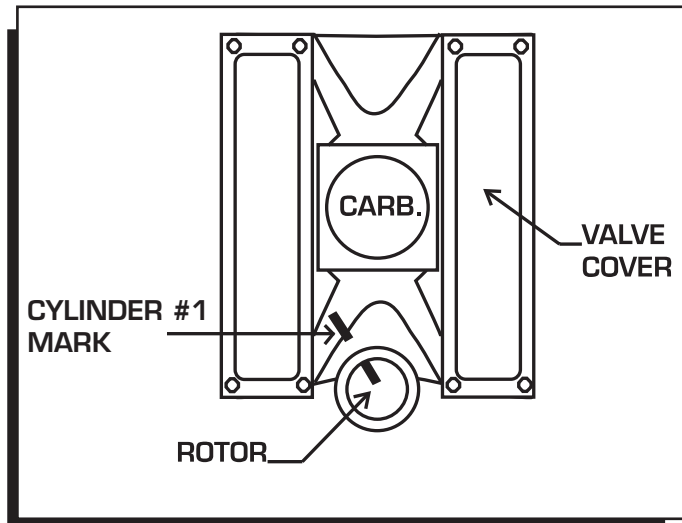

Figure 2 Marking the Rotor Location.

SETTING THE CAM SYNC PICKUP

The Hall-Effect Pickup is designed to provide an aftermarket ECU with a sync signal. This signal must be advanced more than the ignition trigger signal. The amount of advance or lead time depends on the EFI system being used. Always check with the EFI manufacturer to determine the advance required for the cam sync.

For example: An ECU requires 10° of advance. Your engine will be running total timing of 36°. Position the number one cylinder at 46° and align the pickup.

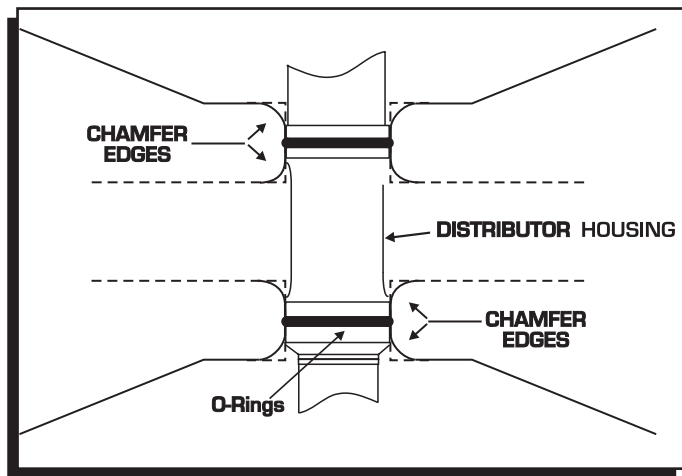

Figure 3 Modified Block for use with O-Rings.

1. Once the distributor is locked in place at your desired total timing, rotate the engine until the number one cylinder is positioned at the required cam sync. (If 10° of sync is required with the engine at 36°, position the engine at 46°).
2. With power going to the Hall-effect pickup, adjust the pickup until the light turns Off (the output will be higher). This will be the 10° of advance for the ECU. It is important to rotate the pickup clockwise until the light turns on, to find the edge of the magnet. Then rotate the pickup CCW just until the light turns off.
3. Lock the pickup sync in position.

Install the distributor cap and spark plug wires one at a time to ensure the correct location. Install the distributor cap and spark plug wires one at a time to ensure correct location. A wire retainer is supplied to secure the wires in place. Align the mounting bosses and use the supplied 1.5" self-tapping Phillips screws to hold the the retainer in place.

ROTOR PHASING

Rotor Phasing is defined as the alignment between the rotor tip and the distributor cap terminal when the spark occurs. This position can be very important to your engine's performance. If the alignment is incorrect, the spark will jump to the next closest terminal or another ground resulting in a misfire and loss of power.

Since the timing is going to be controlled electronically, it is important to position the rotor phasing at, or near the total timing (most advanced). Some race applications with timing retards due to nitrous or boost should split the difference of the retard amount when setting the rotor phasing. For more information, see the supplied Tech Bulletin.

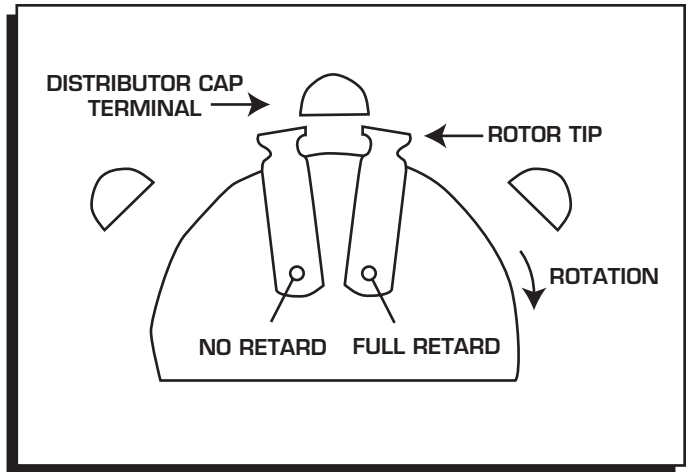

Figure 4 Rotor Phasing.

WARNING: High voltage is present on the coil terminals. Do not touch the terminals or coil tower when the engine is cranking or running.

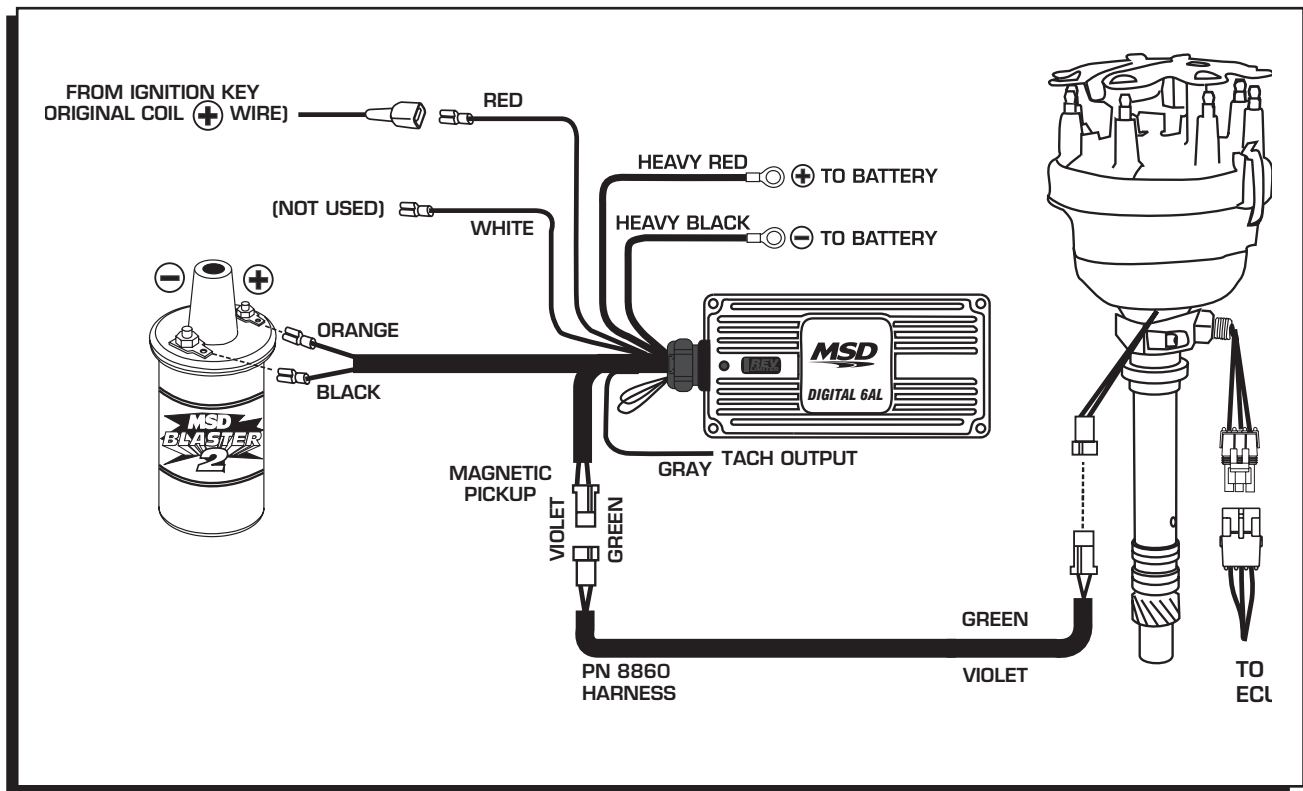

Figure 5 Wiring to an MSD 6-Series Ignition Control.

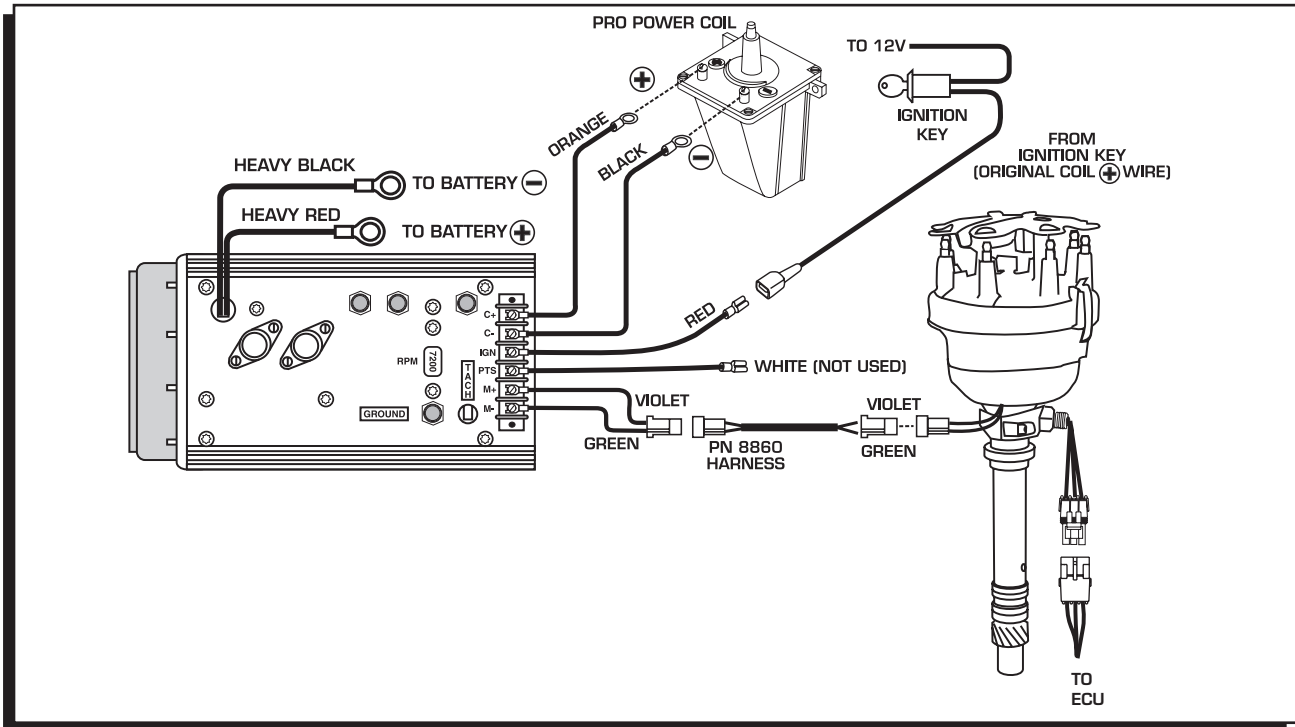

Figure 6 Wiring to an MSD 7-Series Ignition Control.

Service

In case of malfunction, this MSD component will be repaired free of charge according to the terms of the warranty. When returning MSD components for warranty service, **Proof of Purchase** must be supplied for verification. After the warranty period has expired, repair service is based on a minimum and maximum fee.

All returns must have a Return Material Authorization (RMA) number issued to them before being returned. To obtain an RMA number please contact MSD Customer Service at 1 (888) MSD-7859 or visit our website at www.msdpower.com/rma to automatically obtain a number and shipping information.

When returning the unit for repair, leave all wires at the length in which you have them installed. Be sure to include a detailed account of any problems experienced, and what components and accessories are installed on the vehicle. The repaired unit will be returned as soon as possible using Ground shipping methods (ground shipping is covered by warranty). For more information, call MSD at (915) 855-7123. MSD technicians are available from 7:00 a.m. to 5:00 p.m. Monday - Friday (mountain time).

Limited Warranty

MSD warrants this product to be free from defects in material and workmanship under its intended normal use*, when properly installed and purchased from an authorized MSD dealer, for a period of one year from the date of the original purchase. This warranty is void for any products purchased through auction websites. If found to be defective as mentioned above, it will be repaired or replaced at the option of MSD. Any item that is covered under this warranty will be returned free of charge using Ground shipping methods.

This shall constitute the sole remedy of the purchaser and the sole liability of MSD. To the extent permitted by law, the foregoing is exclusive and in lieu of all other warranties or representation whether expressed or implied, including any implied warranty of merchantability or fitness. In no event shall MSD or its suppliers be liable for special or consequential damages.

*Intended normal use means that this item is being used as was originally intended and for the original application as sold by MSD. Any modifications to this item or if it is used on an application other than what MSD markets the product, the warranty will be void. It is the sole responsibility of the customer to determine that this item will work for the application they are intending. MSD will accept no liability for custom applications.