



P/N 199R10495

PRO FOGGER SYSTEMS

Kit Numbers:

- 02462NOS Pro Shot Fogger w/10lb Bottle
- 02464NOS Pro Shot Fogger "Professional Kit" Super "A" Nozzle
- 02020NOS "Upgrade" Pro Shot Fogger 2 Single 4150
- 02021NOS "Upgrade" Pro Shot Fogger 2 Dual 4150
- 02022NOS "Upgrade" Pro Shot Fogger 2 Single 4500
- 02023NOS "Upgrade" Pro Shot Fogger 2 Dual 4500
- 04466NOS Pro Race Fogger "Professional Kit" Soft Plume Nozzle
- 04467NOS Pro Race Fogger "Professional Kit" Annular Nozzle
- 04468NOS Pro Race Fogger 4cyl "Professional Kit" Soft Plume Nozzle

OWNER'S MANUAL

NOTICE: Installation of Nitrous Oxide Systems Inc. products signifies that you have read this document and have agreed to the terms stated within.

It is the purchaser's responsibility to follow all installation instruction guidelines and safety procedures supplied with the product as it is received by the purchaser to determine the compatibility of the product with the vehicle or the device the purchaser intends to install the product on.

Nitrous Oxide Systems Inc. assumes no responsibility for damages occurring from accident, misuse, abuse, improper installation, improper operation, lack of reasonable care, or all previously stated reasons resulting from incompatibility with other manufacturers' products.

Nitrous Oxide Systems Inc. assumes no responsibility or liability for damages incurred by the use of products manufactured or sold by Nitrous Oxide Systems Inc. on vehicles used for competition or racing.

Nitrous Oxide Systems Inc. neither recommends nor condones the use of products manufactured or sold by Nitrous Oxide Systems Inc. on vehicles, which may be driven on public roads or highways, and assumes no responsibility for damages incurred by such use.

NOS nitrous oxide is legal for use in most states when used in accordance with state and local traffic laws. NOS does not recommend or condone the use of its products in illegal racing activities.

NOS has not pursued California Air Research Board (CARB) exemptions for these kits, hence, they are not legal for use on pollution-controlled vehicles in California. A correctly installed NOS nitrous system should not alter the emission control performance of your vehicle under standard EPA test cycle conditions.

NOTICE: The NOS Pro Fogger systems are not intended for use on hatchback type vehicles without the use of a NOS External Aluminum Blow-Down Tube and Racer Safety Pressure Relief Cap. See website or current catalog for correct part numbers.

HAZARDS DEFINED

This manual presents step-by-step instructions that describe the process of installing your NOS Nitrous Oxide Injection System. These procedures provide a framework for installation and operation of this kit. Parts are referenced by name and number to avoid confusion. Within the instructions, you are advised of potential hazards, pitfalls, and problems to avoid. The following examples explain the various hazard levels:

WARNING! Failure to comply with instructions may result in injury or death.

CAUTION! Failure to comply with instructions may result in damage to equipment.

NOTE: This information is important, needs to be emphasized, and is set apart from the rest of the text.

HINT: These special instructions provide a handy work tip.

NITROUS OXIDE INJECTION SYSTEM SAFETY TIPS

WARNINGS

Do not attempt to start the engine if the nitrous has been injected while the engine was not running. Disconnect the coil wire and turn the engine over with the throttle wide open for several revolutions before attempting to start. Failure to do so can result in extreme engine damage.

Never permit oil, grease, or any other readily combustible substances to come in contact with cylinders, valves, solenoids, hoses, and fittings. Oil and certain gases (such as oxygen and nitrous oxide) may combine to produce a highly flammable condition.

Never interchange nitrous and fuel solenoids. Failure to follow these simple instructions can result in extreme engine damage and/or personal injury.

Never drop or violently strike the bottle. Doing so may result in an explosive bottle failure.

Never change pressure settings of safety relief valve on the nitrous bottle valve. Increasing the safety relief valve pressure settings may create an explosive bottle hazard.

Identify the gas content by the NOS label on the bottle before using. If the bottle is not identified to show the gas contained, return the bottle to the supplier.

Do not deface or remove any markings, which are on the nitrous bottle.

Nitrous bottle valves should always be closed when the system is not being used.

Notify the supplier of any condition, which might have permitted any foreign matter to enter the valve or bottle.

Keep the valves closed on all empty bottles to prevent accidental contamination.

After storage, open the nitrous bottle valve for an instant to clear the opening of any possible dust or dirt.

It is important that all threads on the valves and solenoids are properly mated. Never force connections that do not fit properly.

CONGRATULATIONS on purchasing your NOS Nitrous Oxide Injection System. Your system is composed of the highest quality components available. It should provide many miles of trouble-free performance when used correctly. If you have any questions regarding the performance of your system, call NOS Technical Service at 1-866-GOHOLLEY.

TABLE OF CONTENTS:

HAZARDS DEFINED	2
NITROUS OXIDE INJECTION SYSTEM SAFETY TIPS	2
WHAT IS NITROUS OXIDE?	4
Do's and Don'ts of Nitrous Oxide	4
Chapter 1 Introduction to your NOS Nitrous Oxide Kit	5
1.1 General Information	5
1.2 Pro Fogger System Requirements	5
1.3 Kit Components	6
Chapter 2 Kit Installation—Bottle Mounting	9
2.1 Bottle Mounting Instructions	9
2.2 Bottle Orientation	9
2.3 Bottle Installation	10
Chapter 3 Kit Installation (Typical Fogger Kit)	11
3.1 Fogger Nozzle Installation	11
3.2 Fogger Nozzle Feed Tube Mounting	12
3.2.1 Nitrous Feed Tube Installation	12
3.2.2 Fuel Feed Tube Installation	14
3.3 Solenoid Mounting	15
3.3.1 Nitrous Solenoid Installation	15
3.3.2 Fuel Solenoid Installation	15
3.4 Nitrous Solenoid Feed Line Installation	16
3.5 Main Nitrous Feed Line Mounting	16
3.6 Fuel Solenoid Feed Line Installation	16
3.7 Main Fuel Line Installation Tips	16
3.8 Electrical System	16
Chapter 4 “Upgrade” Kit Installation	19
4.1 Injector Plate Mounting	19
4.1.1 Solenoid Mounting (02020NOS and 02022NOS)	20
4.1.1.1 Nitrous Solenoid Installation	21
4.1.1.2 Fuel Solenoid Installation	21
4.1.2 Solenoid Mounting (Kit Numbers 02021NOS and 02023NOS)	21
4.1.2.1 Nitrous Solenoid Installation	21
4.1.2.2 Fuel Solenoid Installation	21
4.2 Electrical System Installation	22
Chapter 5 Baseline Tuning Suggestions	22
Chapter 6 Preparing for Operation	23
Chapter 7 Advanced Tuning for Maximum Power	24
7.1. A Determining Optimum Nitrous/Fuel Ratio	24
A. Correct Timing, Mixture, and Spark Plug Heat Range	24
B. Excessively Rich Mixture	24
C. Detonation	24
D. Excessively Lean Mixture	24
7.1. B Determining Optimum Ignition Timing	24
Chapter 8 Routine Maintenance	27
8.1 Nitrous Solenoid Filter	27
8.2 Nitrous Solenoid Plunger	27
8.2. A General Information	27
8.2. B Nitrous Solenoid Plunger Disassembly and Inspection	27
Appendix A Troubleshooting Guide	28
Nitrous Oxide Accessories	30

WHAT IS NITROUS OXIDE?

NITROUS OXIDE...

...Is a cryogenic gas composed of nitrogen and oxygen molecules

...Is 36% oxygen by weight

...Is non-flammable by itself

...Is stored as a compressed liquid

...Exists in two grades—U.S.P. and Nitrous Plus:

- ❑ U.S.P. is medical grade nitrous oxide; its common use is dental and veterinary anesthesia. It is also commonly used as a propellant in canned whipped cream. U.S.P. is not available to the public.
- ❑ Nitrous Plus differs from U.S.P. in that it contains trace amounts of sulphur dioxide added to prevent substance abuse. Nitrous Plus is intended for automotive applications and is available for sale to the public

In automotive applications, Nitrous Plus and fuel are injected into the engine's intake manifold, which produces the following results:

- ❑ Lowers engine intake air temperature, producing a dense inlet charge.
- ❑ Increases the oxygen content of the inlet charge (air is only 22 percent oxygen by weight).
- ❑ Increases the rate at which combustion occurs in the engine's cylinders.

Do's and Don'ts of Nitrous Oxide

Do's

- ❑ Read all instructions before attempting to install your NOS nitrous system.
- ❑ Make sure your fuel delivery system is adequate for the nitrous jetting you have chosen. Inadequate fuel pressure or flow **will** result in engine damage.
- ❑ Use 14 gauge (minimum) wire when installing electrical system components.
- ❑ Use high-quality connections at all electrical joints.
- ❑ Use Teflon-based **paste** on pipe style fittings.
- ❑ Make sure your engine and related components (ignition, carburetor, and driveline) are in proper working condition.
- ❑ **If nitrous is accidentally injected into the engine when it is not running, remove the engine coil wire, open the throttle, and crank the engine 10 to 15 seconds before starting. Failure to do so can result in an explosive engine failure.**
- ❑ **Use your NOS nitrous system only at wide-open throttle and at engine speeds above 3000 RPM.**
- ❑ **Install a proper engine to chassis ground. Failure to do so may result in an explosive failure of the main nitrous supply line.**
- ❑ Use a high-quality fuel, as suggested in Chapter 3, Baseline Tuning Suggestions.

Don'ts

- ❑ Engage your nitrous system with the engine off. **Severe** engine damage can occur.
- ❑ Modify NOS nitrous systems (if you need a non-stock item, call NOS Technical Service for assistance).
- ❑ Overtighten AN type fittings.
- ❑ Use Teflon Tape on pipe threads. Pieces of Teflon tape can break loose and become lodged in nitrous or fuel solenoids or solenoid filters. Debris lodged in a nitrous or fuel solenoid can cause catastrophic engine failure.



- ❑ Use sealant of any kind on AN type fittings.
- ❑ Allow nitrous pressure to exceed 1100 psi. Excessive pressure can cause swelling or in extreme cases failure of the nitrous solenoid plunger. Solenoid plungers are designed so that pressure-induced failures will prevent the valve from operating. No leakage should occur with this type of failure.
- ❑ **Inhale nitrous oxide. Death due to suffocation can occur.**
- ❑ **Allow nitrous oxide to come in contact with skin. Severe frostbite can occur.**
- ❑ Use octane boosters that contain methanol. Fuel solenoid failure may occur, producing severe engine damage.

Chapter 1 Introduction to your NOS Nitrous Oxide Kit

1.1 General Information

Direct port nitrous oxide injection kits are intended to provide maximum performance and tunability in a nitrous oxide injection system. The Pro Shot and Pro Race Fogger Kits are intended for highly modified domestic V8 engines using carburetors.

Kits 02020NOS, 02021NOS, 02022NOS, and 02023NOS can be used to convert Kits 02462NOS, 02464NOS, 04466NOS, or 04467NOS into a two-stage kit (Cheater plates and direct port injection). These systems are designed to work with highly modified domestic V8 engines of at least 450 cubic-inch displacement.

Horsepower increases from these kits will vary with engine displacement and configuration. However, approximate power increases can be estimated based upon the mass flow of nitrous oxide into the engine. On a typical 450+ C.I. displacement engine, the following power increases approximate what you can expect to see.

Table 1 Pro Fogger Kit Configurations

Configuration	HP	Jetting		Baseline Pressures*		Fuel Quality	Ignition Timing	Spark Plug Heat Range (NGK or Equiv))
		N ₂ O	Fuel	N ₂ O	Fuel			
Fogger Jetting	150	22	18	950	6PSI	100+ Octane	***	-8
	175	24	20	950	6PSI	110+ Octane	***	-9
	250**	28	24	950	6PSI	112+ Octane	***	-10
	300**	32	28	950	6PSI	114+ Octane	***	-10
	350**	36	32	950	6PSI	114+ Octane	***	-11
	400	40	36	950	6PSI	116+ Octane	***	-11
	500	42	38	950	6PSI	116+ Octane	***	-11
Upgrade Cheater Plate Jetting (Single Plate)	100**	47	47	950	6PSI	If adding this kit to a Fogger kit, add the 2 HP levels together and use the Octane rating to the right of the HP as shown above in the Fogger jetting section	***	If adding this kit to a Fogger kit, add the 2 HP levels together and use the Plug Heat Range to the right of the HP as shown above in the Fogger jetting section
	125**	55	55	950	6PSI		***	
	150**	63	63	950	6PSI		***	
	175**	73	73	950	6PSI		***	
	200**	82	82	950	6PSI		***	
	250**	93	93	950	6PSI		***	
Upgrade Cheater Plate Jetting (Dual Plate)	100**	33	33	950	6PSI		***	
	125**	38	38	950	6PSI		***	
	150**	52	52	950	6PSI		***	
	175**	59	59	950	6PSI		***	
	200**	65	65	950	6PSI		***	
	250**	73	73	950	6PSI		***	

* **Baseline Pressures are set as follows:** Fuel is set as a flowing pressure through a .073 jet for the Fogger kits and the actual jet used on the Cheater plates.

** **Jetting included in Kits**

*** **See section 7.1.B for timing recommendations**

For a 4 cyl, divide the HP numbers in half.

1.2 Pro Fogger System Requirements

When used correctly, NOS nitrous oxide injection elevates cylinder pressures and temperatures while increasing the combustion rate. These characteristics make the engine more sensitive to detonation. **To ensure proper performance and engine life, the following is an absolute must:**

NOTE: Most fuel pumps are rated at free-flowing conditions. At 5 psi, their flow rates may be greatly reduced.

☐ Adequate Fuel Pressure and Delivery

Most carburetors are designed to work at 5-10 psi. When designing your fuel system, plan on your pumps and lines flow at least 0.10 gallons of *gasoline* per hour per horsepower at 5 psi.

❑ Forged Pistons

Cast pistons are very prone to failure at elevated cylinder temperatures and pressures.

❑ Connecting Rods

Standard forged connecting rods tend to buckle under the high compressive loads generated with large doses of nitrous oxide. For most applications, an aftermarket steel billet rod is acceptable. For extremely high output applications, aluminum connecting rods are suggested.

❑ Crankshaft

Stock cast crankshafts may break. Stock forgings can bend or twist in high output applications. Aftermarket units are recommended for very high output applications.

❑ Cylinder Block

Four bolt main cap blocks reduce the tendency for the main caps to ~~walk~~ "walk" under high output loading. Cylinder head studs decrease the chance of cylinder heads lifting or moving relative to the deck surface.

❑ High Output Ignition System

Stock ignition systems are prone to producing misfires at high-RPM conditions. A quality aftermarket racing ignition is suggested.

1.3 Kit Components

Before beginning the installation of your NOS kit, compare the components in your kit with those shown in Figure 1 and 2 and listed in Table 2 or 3. If any components are missing, please contact NOS Technical Support at 1-866-GOHOLLEY.

Table 2 Pro Fogger Parts List

Item	Description	Quantity	NOS P/N
(1)	Bottle Valve Adapter	1	16230NOS ¹
(2)	Bottle 10 lb. Washer	1	16210NOS ¹
(3)	Bottle Bracket Set	1	14125NOS ¹
(4)	Nitrous Oxide Bottle 10 lb.	1	14745NOS ¹
(5)	1/16" NPT Tap	1	15990NOS ¹
(6)	Fogger Nozzle	8	***
(7)	3AN x 3/16" B-Nut (Blue)	8	17550NOS
(8)	3AN x 3/16" Sleeve (Blue)	8	17600NOS
(9)	3AN x 3/16" B-Nut (Red)	8	17551NOS
(10)	3AN x 3/16" Sleeve (Red)	8	17601NOS
(11)	# 24, 28, 32, & 36 SS Flare Jets	8 each	***
(12)	3/16" x 12" SS tube	16	16365-SNOS
(13)	1/8" NPT Distribution Block	4	34R12808 / 34R12809
(14)	1/4-28 x 3/16" Compression Fitting	16	16442-RNOS
(15)	Pro Race N ₂ O Solenoid	2	16048RNOS
(16)	1/8" NPT x 1/8" NPT 90° Fitting	2	17530NOS
(17)	N ₂ O Filter	2	15564NOS
(18)	Cheater Fuel Solenoid	2	16050NOS
(19)	1/8" NPT x 6AN Filter Fitting	2	15569NOS
(20)	6AN 1ft Hose, Blue	2	15400NOS
(21)	6AN Y Fitting (Blue)	1	17835NOS
(22)	6AN 14 ft. N ₂ O Hose	1	15475NOS ¹
(23)	Microswitch and Bracket	1	15640NOS ¹
(24)	Arming Switch	1	15602NOS ¹
(25)	Relay—30 amp**	1	15618NOS ¹
(26)	1/8" NPT Male Nipple	2	17500NOS

** Wiring and connectors also supplied.

*** Part number varies with application.

¹ These parts are only included in the 02462NOS kit. This kit also uses a 16045NOS nitrous solenoid in place of the 16048RNOS solenoid

Figure 1 Pro Fogger Kit Components

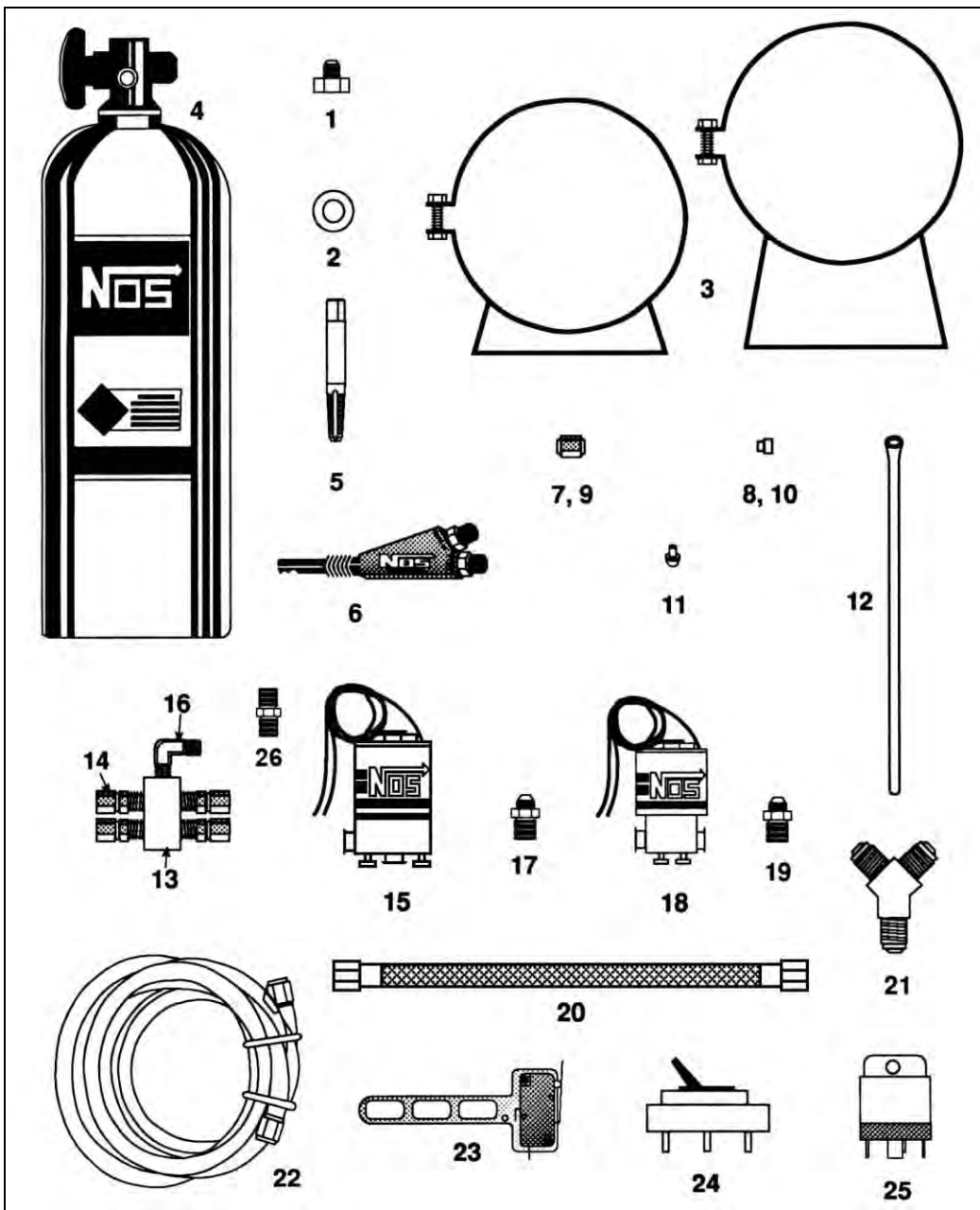
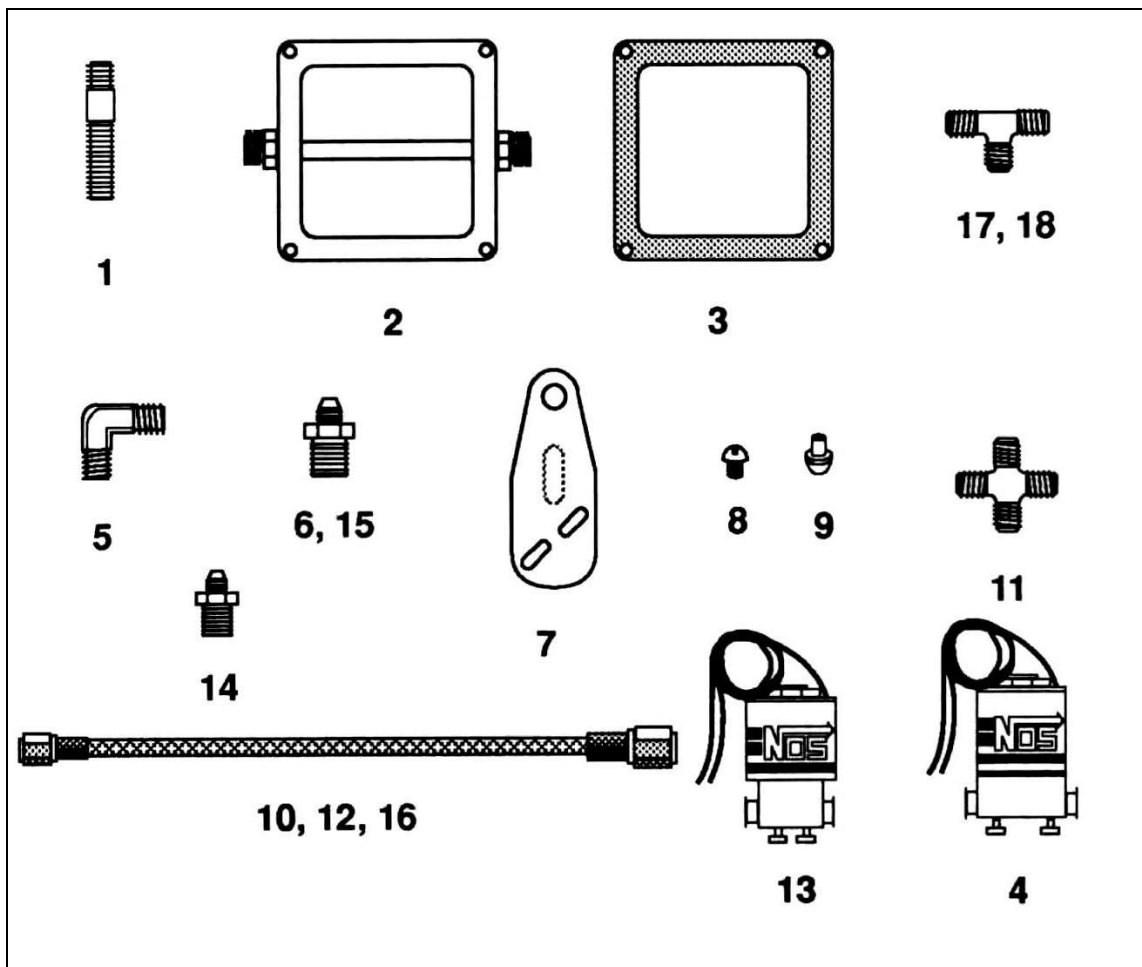

Table 3 Pro Shot Fogger II Upgrade Kit Parts List

Item	Description	Quantity	NOS P/N
(1)	Carburetor Studs	***	***
(2)	Injector Plate	***	***
(3)	Carburetor Gaskets	***	***
(4)	N ₂ O cheater Solenoid	1	16000NOS
(5)	N ₂ O Filter	1	15562NOS
(6)	1/8" NPT x 4AN Fitting (Blue)*	***	17960NOS
(7)	Solenoid Mounting Bracket	2	16500NOS
(8)	Solenoid Mounting Screws	4	16501-SNOS
(9)	Flare Jets	***	***
(10)	4AN x 3AN Hose (Blue)	***	***
(11)	6AN Cross	1	17820NOS
(12)	18" 4AN x 6AN Hose (Blue)	1	15355NOS
(13)	Fuel Cheater Solenoid	1	16050NOS
(14)	1/8" NPT x 6AN Fitting (Red)	1	17986NOS
(15)	1/8" NPT x 4AN Fitting (Red)*	***	17961NOS
(16)	4AN x 3AN Hose (Red)	***	***
(17)	1/8" NPT x 4AN TEE (Blue)**	***	17260NOS
(18)	1/8" NPT x 4AN TEE (Red)**	***	17261NOS

* Only in single plate application
 ** Only in dual plate applications
 *** Part number varies with application.

Figure 2 Pro Shot Fogger II Upgrade Kit components



Chapter 2 Kit Installation—Bottle Mounting

2.1 Bottle Mounting Instructions

NOTE: Disconnect the battery ground before beginning installation.

Before mounting a nitrous bottle in a racing vehicle intended for use in sanctioned events, check with the sanctioning association for any rules regarding this subject. Most associations require the bottle to be mounted within the confines of the safety roll cage with the safety pressure relief cap vented away from the driver's compartment. NOS offer a special safety pressure relief cap (P/N 16169NOS) and an aluminum blow-down tube (P/N 16160NOS) for this purpose.

Figure 3 Nitrous Bottle Siphon Tube Orientation

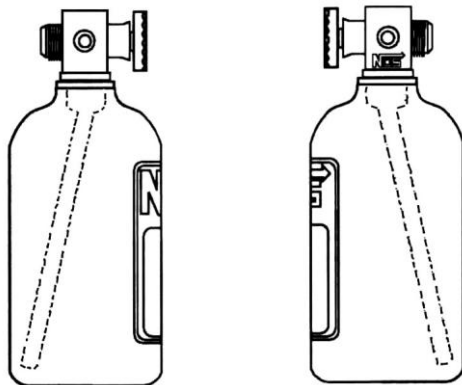
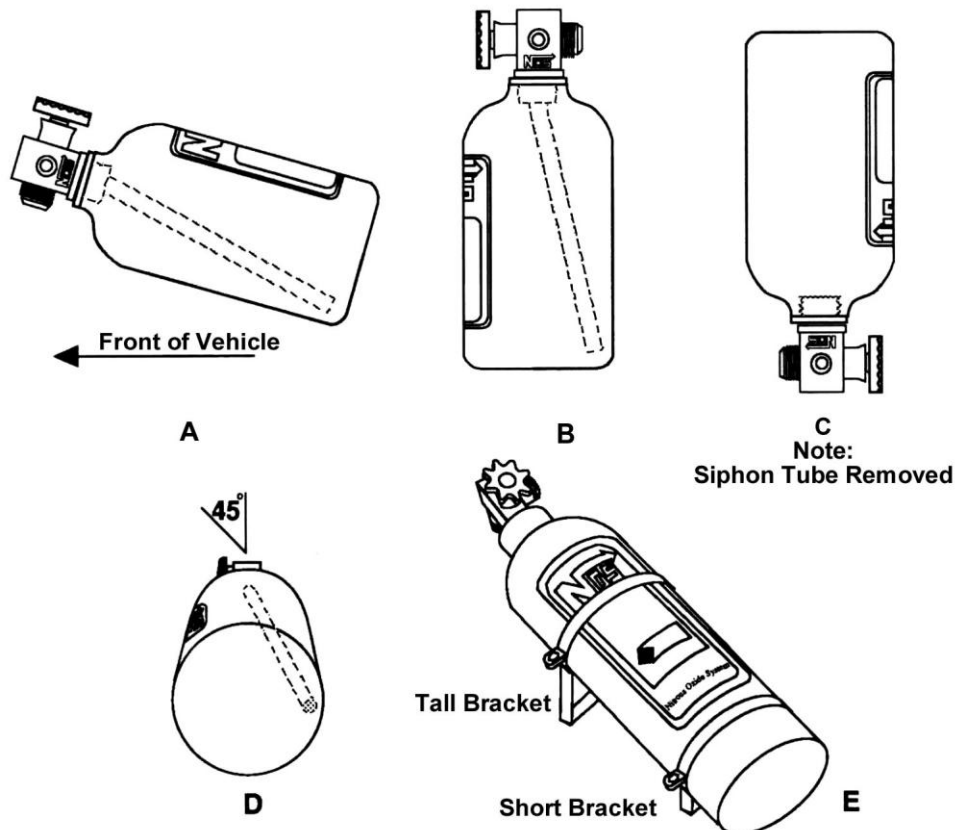

Figure 4 Nitrous Bottle Mounting Orientations



2.2 Bottle Orientation

Bottle placement is critical to the performance of your NOS nitrous system. It is important to understand how the bottle valve and siphon tube are assembled to properly orient the bottle in your vehicle and ensure that it picks up liquid nitrous while undergoing acceleration. All NOS nitrous bottles are assembled so that the bottom of the siphon tube is at the bottom of the bottle and opposite the bottle label (Figure 3).

Whenever the bottle is mounted in a lay-down position, the valve handle must be towards the front of the vehicle with the label facing up (Figure 4A).

If the bottle is mounted vertically, the valve handle and label must face toward the front of the vehicle (Figure 4B). This orientation will position the siphon tube at the back of the bottle where the liquid N₂O will be during acceleration.

WARNING! DO NOT attempt to remove the siphon tube without completely emptying the bottle of all nitrous and pressure. Failure to completely empty the bottle will result in an explosive condition causing injury or death.

A bottle mounted upside-down must have the siphon tube removed before use (Figure 4C). Non-siphon bottles can be specially ordered from NOS.

If the bottle must be mounted parallel to the axles of the vehicle (sideways), the valve handle and label must be angled at approximately 45° toward the front of the vehicle (Figure 4D). This orientation will position the siphon tube toward the rear of the bottle.

NOTE: When using a bottle with a siphon tube, the tall bracket should be at the valve end of the bottle and the short bracket at the bottom (Figure 4E).

The most efficient mounting is the lay-down position (Figure 4A) with the valve handle toward the front of the vehicle. This position allows the greatest amount of liquid to be used before the siphon tube begins to pick up gaseous nitrous oxide.

2.3 Bottle Installation

After you have determined the location and orientation of the nitrous bottle, use the following procedure to install the bottle:

NOTE: Numbers in parentheses () refer to the parts list/assembly drawing number for the component (Included in Kit # 02462NOS only). Figure 5 shows the installation for the Pro Fogger System Kits.

1. Install the bottle nut adapter (1) and washer (2) on the nitrous bottle (4), and tighten securely.
2. Loosely install the bottle mounting brackets (3) on the nitrous bottle.
3. Locate the bottle assembly in the desired mounting location, ensuring that the location will provide easy access to the bottle valve, hose connection, and bracket clamp bolts to facilitate bottle changing.
4. Use the assembled bottle/bracket/blow-down tube unit as a pattern to mark hole drilling. Drill four 5/16" holes for the bottle bracket bolts, a 1/2" hole for the blow-down tube, if used, and a 13/16" hole for the nitrous supply line.
5. Mount the brackets securely to the surface (recommended minimum of 5/16" bolts or No. 12 sheet metal screws).
6. Tighten the bracket clamps on the bottle.

Figure 5 Typical Fogger Exploded View

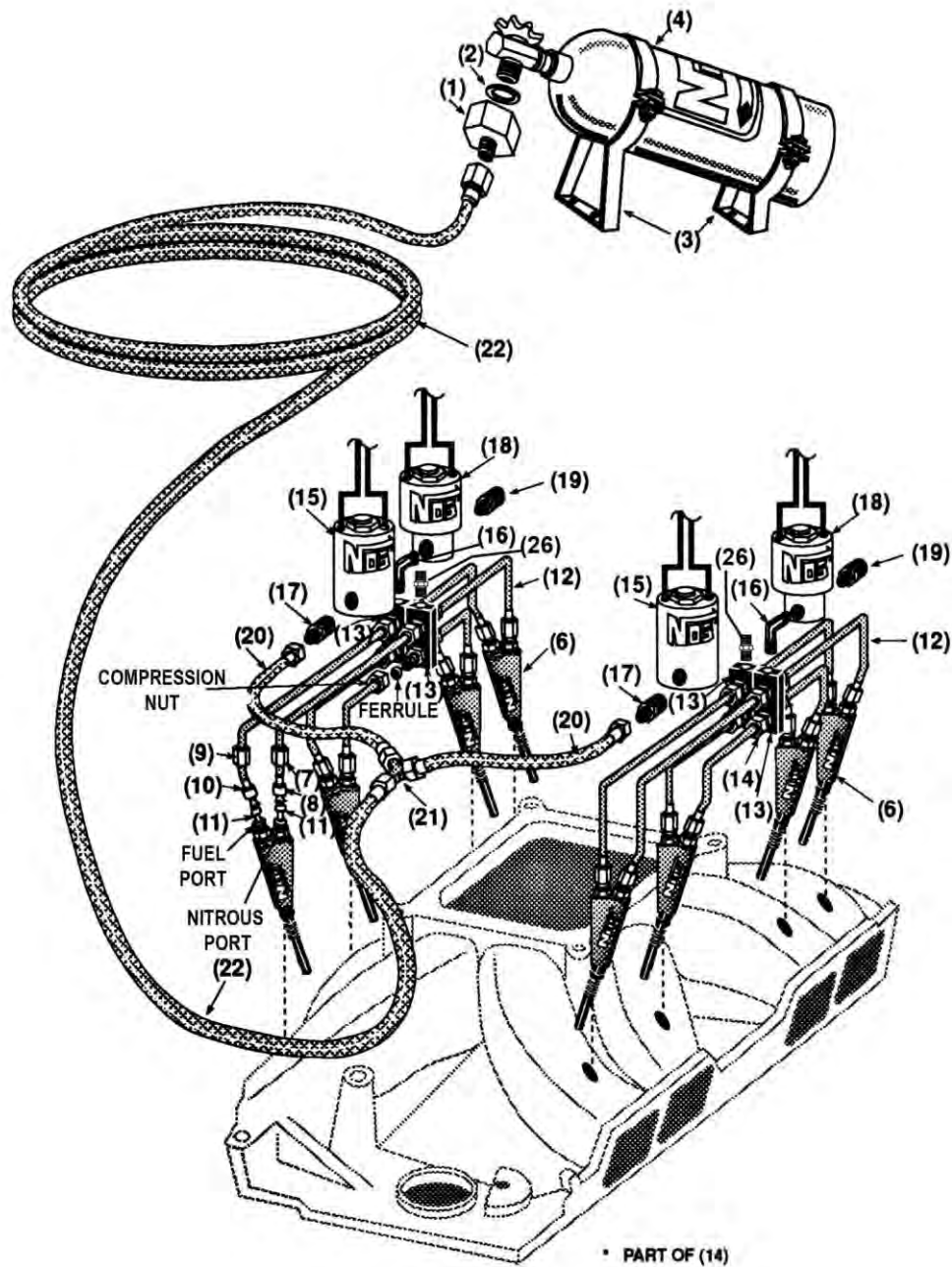

Chapter 3 Kit Installation (Typical Fogger Kit)

NOTE: Numbers in parentheses () refer to the parts list/assembly drawing number for the component. Figure 5 shows the typical installation for a Pro Fogger System.

3.1 Fogger Nozzle Installation

Figure 6 & 7 display a typical Fogger nozzle installation location. Use this figure as a guide for locating your nozzles.

NOTE: When mounting Fogger nozzles, ensure that the nozzles and feed lines do not interfere with engine components.

1. Mark the desired Fogger nozzle mounting locations on the intake manifold.

NOTE: When selecting mounting locations, note the discharge orientation of the nozzle. If possible, mount the nozzle so that the N₂O discharge orifice points down port, aimed at the intake valve head.

2. Remove the intake manifold from the engine.

3. Drill a 1/4" diameter hole into the intake manifold at each Fogger nozzle mounting location. For aesthetic purposes, all holes on each cylinder bank should be drilled to line up straight.

NOTE: Holes should be tapped just deep enough for the discharge orifice of the Fogger nozzle head to protrude through. Be careful not to tap holes too deep, as the Fogger nozzle may not adequately seal.

4. Tap each 1/4" hole with the 1/16" NPT tap (5).
5. Remove all debris from the intake manifold.

HINT: Apply Teflon paste to the threads of each Fogger nozzle before installing them in the manifold. This will help prevent vacuum leaks into the intake manifold.

6. Install a Fogger nozzle (6) into each 1/4" hole, orienting the nozzles so the discharge orifices are pointed down the manifold port toward the intake valve.

NOTE: The intake manifold can be installed on the engine any time after the fogger nozzles are secured in place.

7. Examine Chapter 5, Baseline Tuning Suggestions, for proper nitrous and fuel jet selection for your application. Install the desired flare jets (11) in the Fogger nozzles.

Figure 6 Fogger Nozzle Mounting Position—2x4V Intake

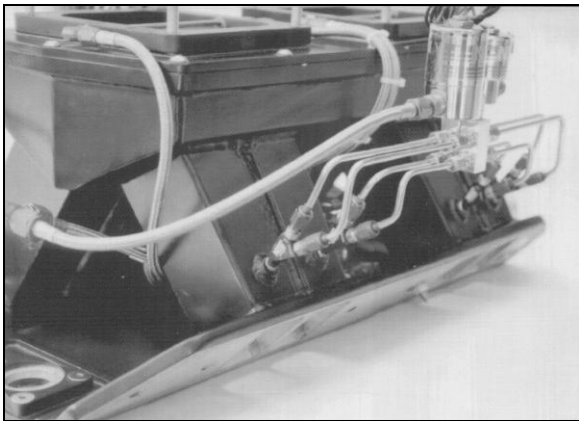
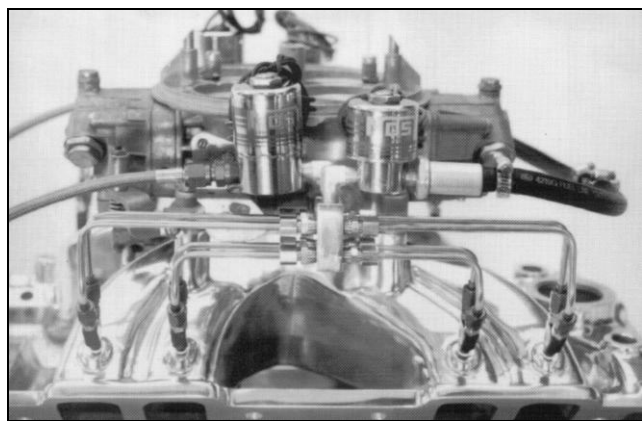

Figure 7 Fogger Nozzle Mounting Position—Single 4V Intake



3.2 Fogger Nozzle Feed Tube Mounting

3.2.1 Nitrous Feed Tube Installation

NOTE: For professional looking results, the following steps need to be performed with a quality tube-bending tool. NOS sells a tool for this purpose under P/N 15991NOS.

NOTE: If you are not experienced in tube bending, it is advisable that before you bend each solenoid extension tube, you make a sample tube using either a piece of brake line or a coat hanger. This "practice" will help you minimize errors and help you to produce an aesthetically pleasing plumbing job.

1. Install the four compression fittings into the blue distribution block (13). Remove the compression nuts and ferrules from the compression fitting bodies. Apply Loctite™ to the 1/4"-24 threads on the distribution block fittings. Install and tighten all the fittings into the distribution block.
2. Select two of the 12" solenoid extension tubes (12), and measure 1" in from the flared end and mark. Install a Blue B-Nut (9) and Blue sleeve (10) on the flared end.
3. Make a 90° bend in the two solenoid extension tubes at the 1" mark. The bend should start at the 1" mark and proceed away from the end of the tube.
4. Install the two bent solenoid extension tubes and B-Nut assemblies on the nitrous inlet ports of the center two Fogger nozzles on one bank of the manifold, with the lone legs of the tube crossing. Measure between the insides of the tubes and place a center mark across both tubes. Refer to Figure 8.

Figure 9 Solenoid Extension Tube Installation

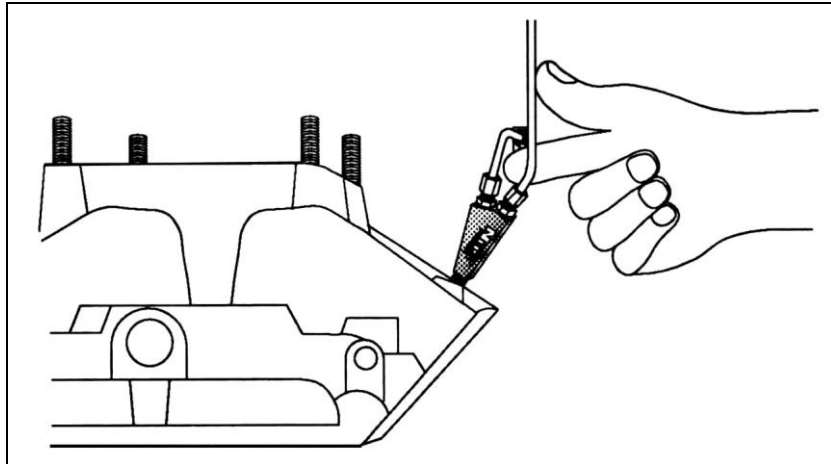
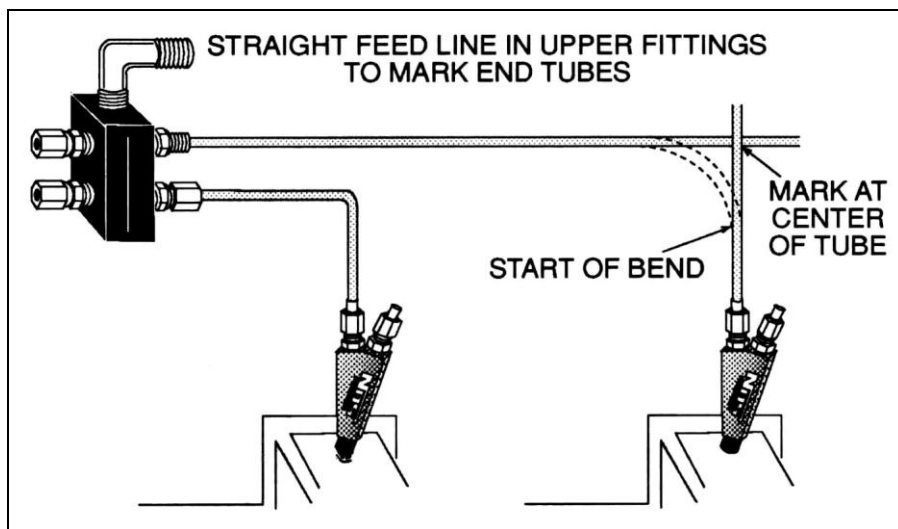

Figure 10 End Fogger Nozzle Feed Tubes



17. Install the compression fitting nuts and ferrules on the "smoothed" ends of the solenoid extension tubes.
18. Insert the solenoid extension tubes into the compression fitting bodies. Lightly tighten the compression nuts.
19. Connect and tighten the solenoid extension tubes to the Fogger nozzles.
20. Tighten all the nitrous tube fittings.
21. Repeat Steps 1-20 for the other side of the manifold.

3.2.2 Fuel Feed Tube Installation

NOTE: For professional looking results, the following steps need to be performed with a quality tube-bending tool. NOS sells a tool for this purpose under P/N 15991NOS.

NOTE: If you are not experienced in tube bending, it is advisable that before you bend each solenoid extension tube, you make a sample tube using either a piece of brake line or a coat hanger. This "practice" will help you minimize errors and help you to produce an aesthetically pleasing plumbing job.

22. Install the four compression fittings into the red distribution block (13). Remove the compression nuts and ferrules from the compression fitting bodies. Apply Loctite™ to the 1/4"-24 threads on the distribution block fittings. Install and tighten all the fittings into the distribution block.
 1. Clamp the distribution block to the outside of the fuel distribution block.
 2. Select four of the 12" solenoid extension tubes (12), and install a red B-Nut (7) and a red sleeve (8) on the flared end.

3. Install the two solenoid extension tubes on the center two nozzles.
4. With your thumb and forefinger, bend the two tubes inwards, so that they are aligned with the compression fittings in the distribution block. Refer to Figure 9.
5. Insert and hold in place an unbent 12" solenoid extension tube in the two lower ports of the distribution block. The extension tubes should be positioned so that they intersect each of the previously bent nitrous solenoid extension tubes at 90° angles. Place a mark on both previously bent fuel solenoid extension tubes at the **center** of the horizontal tubes. Refer to Figure 10.
6. Remove the unbent 12" solenoid extension tubes from the compression fittings.
7. Remove the two center nitrous feed tubes. Bend the tubes 90°. The tube should be placed in the tubing bender, such that the marks on the tubes align with the "finished" bend mark on the tube bender. The bend should proceed away from the flared end.
8. Install and loosely tighten the two bent fuel solenoid extension tubes.
9. Place a mark on the two installed fuel solenoid extension tubes at the inside edge of the two exposed compression fitting body thread sections. Refer to Figure 8.
10. Remove the two fuel solenoid extension tubes. Cut off the tubes at the inside end marks. Deburr and ream the cut ends.

NOTE: Be sure to remove any debris left from cutting and deburring from the inside of the tube before assembly.

11. Install the compression fitting nuts and ferrules on the "smoothed" ends of the solenoid extension tubes.
12. Insert the solenoid extension tubes into the compression fitting bodies. Lightly tighten the compression fittings.
13. Connect and tighten the solenoid extension tubes to the Fogger nozzles.
14. Tighten the compression nuts securely.
15. Repeat Steps 4-15 for outboard Fogger nozzles, using the two upper ports in the distribution block.
16. Repeat Steps 3-16 for the engine's other cylinder bank.

3.3 Solenoid Mounting

Use the following procedures to install the nitrous solenoid (15) and the fuel solenoid (18).

CAUTION: Do not over tighten the vise in the following procedure, or the solenoid will be damaged.

NOTE: Apply Teflon based paste to all pipe fittings before assembling solenoids.

3.3.1 Nitrous Solenoid Installation

1. Clamp the nitrous solenoid (15) in a bench vise.
2. Loosely install the 1/8" male nipple fitting (26) into the outlet port of the nitrous solenoid.
3. Loosely install the nitrous filter fitting (17) into the inlet port of the nitrous solenoid.
4. Trial fit the solenoid, nitrous filter, and fitting in the nitrous distribution block. Note the orientation of the fitting and solenoid. Disassemble the fitting, nitrous filter, solenoid, and distribution block.
5. Reassemble the solenoid, fitting, nitrous filter, and distribution block using the Teflon paste. Tighten the connections to attain the desired mounting orientation.
6. Repeat steps 1-5 for the other cylinder bank.

3.3.2 Fuel Solenoid Installation

1. Clamp the fuel solenoid (18) in a bench vise.
2. Loosely install a 90° fitting (16) into the outlet port of the fuel solenoid.
3. Install the red 1/8" NPT x 6AN fitting and the 90° fitting in the fuel distribution block. Note the orientation of the solenoid and fittings. Disassemble the 90° fitting, solenoid, and distribution block.

4. Trial fit the solenoid, red 1/8" NPT x 6AN fitting, and 90° fitting in the fuel distribution block. Note the orientation of the fittings and solenoid. Disassemble the 90° fitting, solenoid, and distribution block.
5. Reassemble the solenoid, 90° fitting, and distribution block using the Teflon paste. Tighten the connections to attain the desired mounting orientation.
6. Repeat steps 1-5 for the other cylinder bank.

3.4 Nitrous Solenoid Feed Line Installation

1. Install a 12" 6AN Hose (20) on each nitrous solenoid.

NOTE: The —Upgrade" kits use a blue 6AN Y fitting in step 2.

2. Connect each 12" 6AN Hose (20) to the blue 6AN Y fitting (21).

3.5 Main Nitrous Feed Line Mounting

HINT: Most late-model vehicles have access plugs in the trunk floor that are convenient for line routing. Following the fuel lines along the underbody, and entering the engine bay through the front fender well usually works well.

1. Determine the route for your nitrous feed line to follow. Ensure the path is clear of exhaust system, suspension, steering, wheels, electrical lines and components, and tires.
2. Feed the main nitrous supply line (22), (included in kit 02462NOS only) along the proposed route.
3. If it is necessary to support the nitrous supply line under the vehicle, use 1/2" Tinnerman clamps or nylon tie-wraps to support the line securely.
4. Attach the nitrous supply line to the nitrous bottle valve adapter (1).

WARNING: Nitrous oxide is dangerous to humans if inhaled or comes in contact with the skin. Always point the nitrous line opening away from people when purging the line.

5. Purge the nitrous supply line.
 - A. Wrap the end of the nitrous line with a rag and hold securely.
 - B. Point the opening **away** from people.
 - C. Briefly open the bottle valve.
6. Attach the nitrous supply line to the nitrous solenoid inlet port.

3.6 Fuel Solenoid Feed Line Installation

1. Connect the open ends of the red 1/8" NPT x 6AN fittings (19) installed in the inlet ports of the fuel solenoids to a filtered fuel supply.

3.7 Main Fuel Line Installation Tips

CAUTION: The primary fuel line for your nitrous system should be a separate line dedicated to the nitrous system. **Be sure your fuel pump, lines, and regulator are capable of handling the fuel requirements of this system.** Inadequate fuel delivery will result in catastrophic engine failure.

3.8 Electrical System

Refer to Figures 12 & 13 and procedures in this section for electrical system installation.

WARNING! Death or injury may occur from working on a charged electrical system.

1. Disconnect the car battery at the ground cable (if not already done).

WARNING! Binding or dragging of the throttle linkage will create a potentially dangerous stuck-throttle condition. Ensure that the microswitch does not interfere with normal throttle linkage operation.

2. Install the throttle microswitch (23) (included in 02462NOS kit only) as follows:

HINT: The microswitch may be mounted to the bracket in a variety of positions and on either side of the bracket. The bracket may be bent to suit the application.

- A. Mount the throttle microswitch on the carburetor/intake manifold so that the throttle linkage movement triggers the microswitch.

- B. Adjust the microswitch to trigger at wide-open throttle by adjusting the microswitch's position to ensure the actuation arm of the microswitch "clicks" at the same point your throttle linkage reaches wide-open throttle against the throttle stop (Position 11A).
- C. Ensure that the microswitch is activated by the accelerator pedal: Have an assistant slowly press the pedal to the floor while you listen for the "click" of the microswitch (Position 11B).

Figure 11 Throttle Microswitch Installation

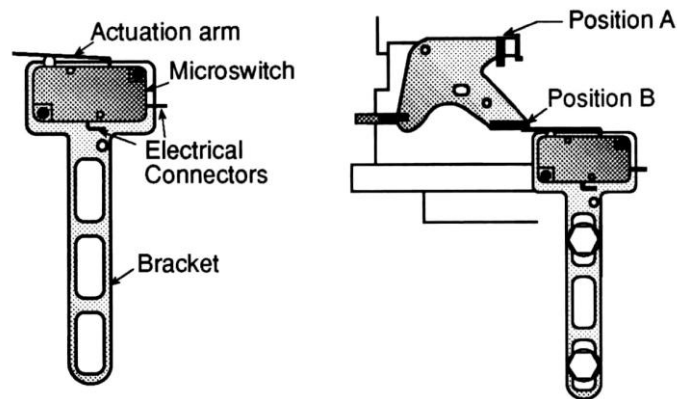

- 3. Install the NOS arming switch (24) (included in 02462NOS kit only) in the vehicle interior, within easy reach of the driver.
- 4. Install the wiring relay (25) (included in 02462NOS kit only) in the engine compartment near the battery. The relay's orange wire should reach the battery (+) terminal.
- 5. Connect the orange relay wire to the battery (+) terminal.
- 6. Connect one wire from each solenoid together. Join the solenoid wires to the blue relay wire.
- 7. Connect the green relay wire to a good chassis ground.
- 8. Connect the red relay wire to either terminal on the microswitch.
- 9. Connect the open terminal on the microswitch to the middle (#2) terminal on the arming switch.
- 10. Connect #1 terminal on the arming switch to the switched +12 volt power source.
- 11. Connect #3 terminal of the arming switch to the ground.
- 12. Reconnect the battery.

CAUTION: Make certain the nitrous bottle is closed and the fuel pump is not running. Failure to comply will result in the intake manifold being filled with nitrous and/or fuel creating a potential engine explosion on start up.

- 13. Temporarily ground the open lead of the nitrous solenoid.
- 14. Turn the arming switch on.
- 15. Hold the throttle wide open. You should hear a clicking noise if the nitrous is cycling correctly. If no noise is heard, check all the wiring connections and the wiring schematic.
- 16. Connect the remaining solenoid wire from each solenoid to the ground.

Figure 12 Kit Typical Fogger Wiring Schematic

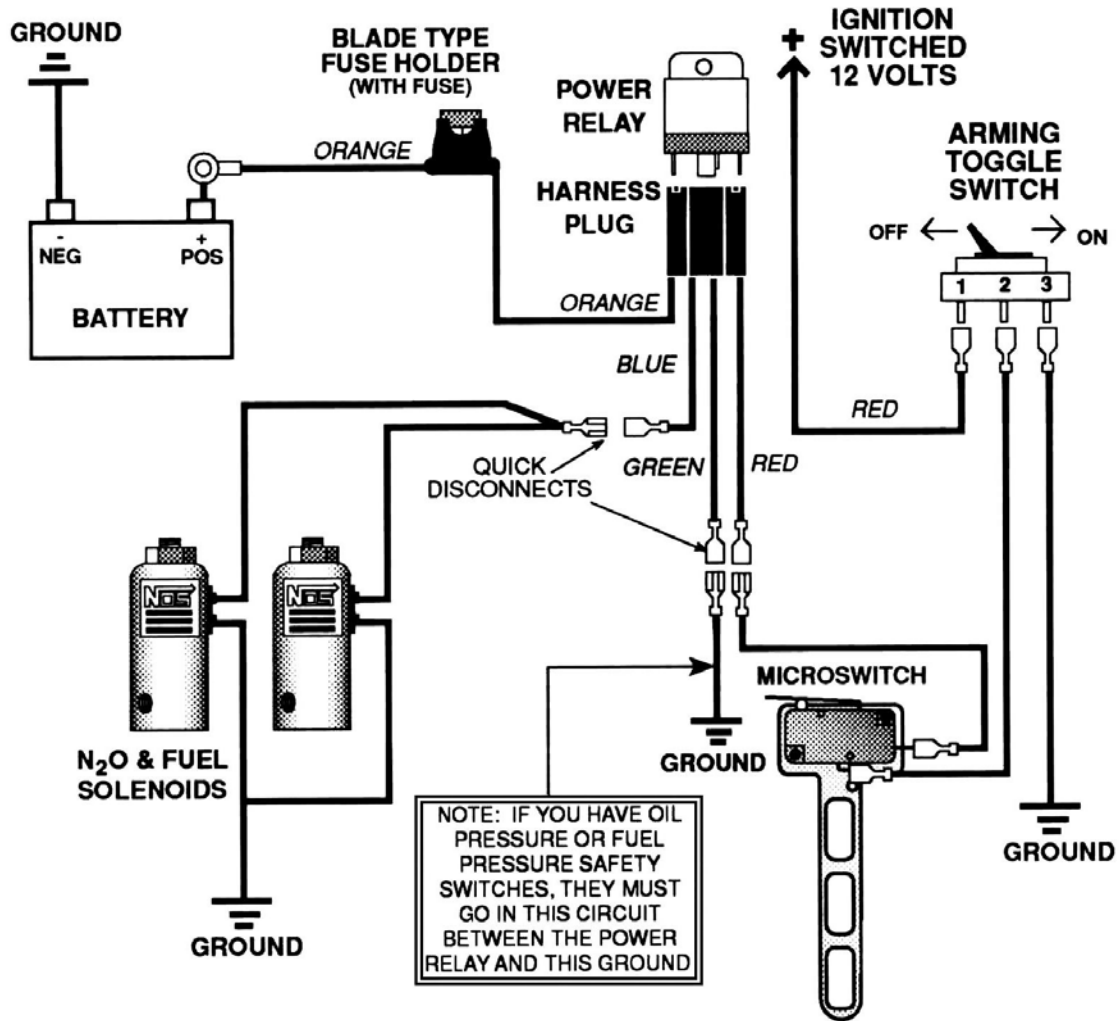

FUZE VALUES	
PRO SHOT SERIES	25 AMP

WIRING COLOR KEY	
ORANGE	TO BATTERY POSITIVE (+) TERMINAL
BLUE	TO ONE WIRE FROM EACH SOLENOID
GREEN	TO GROUND
RED	TO IGNITION SWITCHED +12V THROUGH MICROSWITCH AND ARMING SWITCH

Figure 13 Typical Fogger + Upgrade Plate kit Wiring Schematic

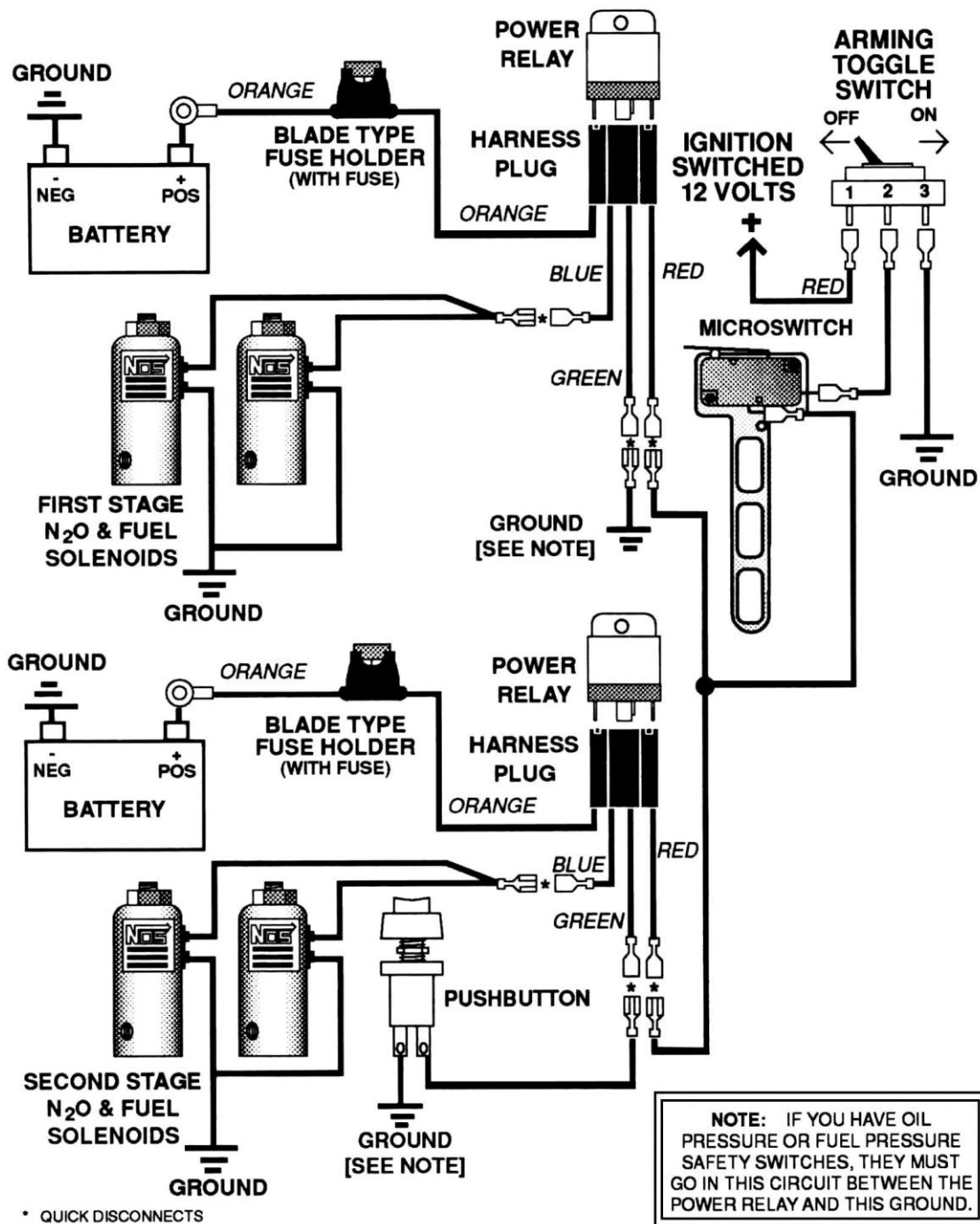

Chapter 4 "Upgrade" Kit Installation

NOTE: Numbers in parentheses () refer to the parts list/assembly drawing number for the component. Figure 14 shows the installation assembly for the Pro Fogger II upgrade kit.

4.1 Injector Plate Mounting

1. Remove the carburetor inlet duct.
2. Disconnect the throttle linkage from the carburetor.
3. Disconnect the fuel lines from the carburetor.
4. Remove the carburetor.

5. Remove the stock carburetor studs.
6. Install the extended carburetor studs (1).
7. Install the Injector Plate (2) and Gaskets (3) on the intake manifold **with the NOS label facing up**.
8. Install the carburetor.
9. Connect the throttle linkage.
10. Repeat Steps 1-9 for an additional carburetor (Kit Numbers 02021NOS and 02023NOS)

4.1.1 Solenoid Mounting (02020NOS and 02022NOS)

Use the following procedures to install the nitrous solenoid and fuel solenoid.

Figure 14 Kit Number 02021NOS and 02023NOS Exploded View

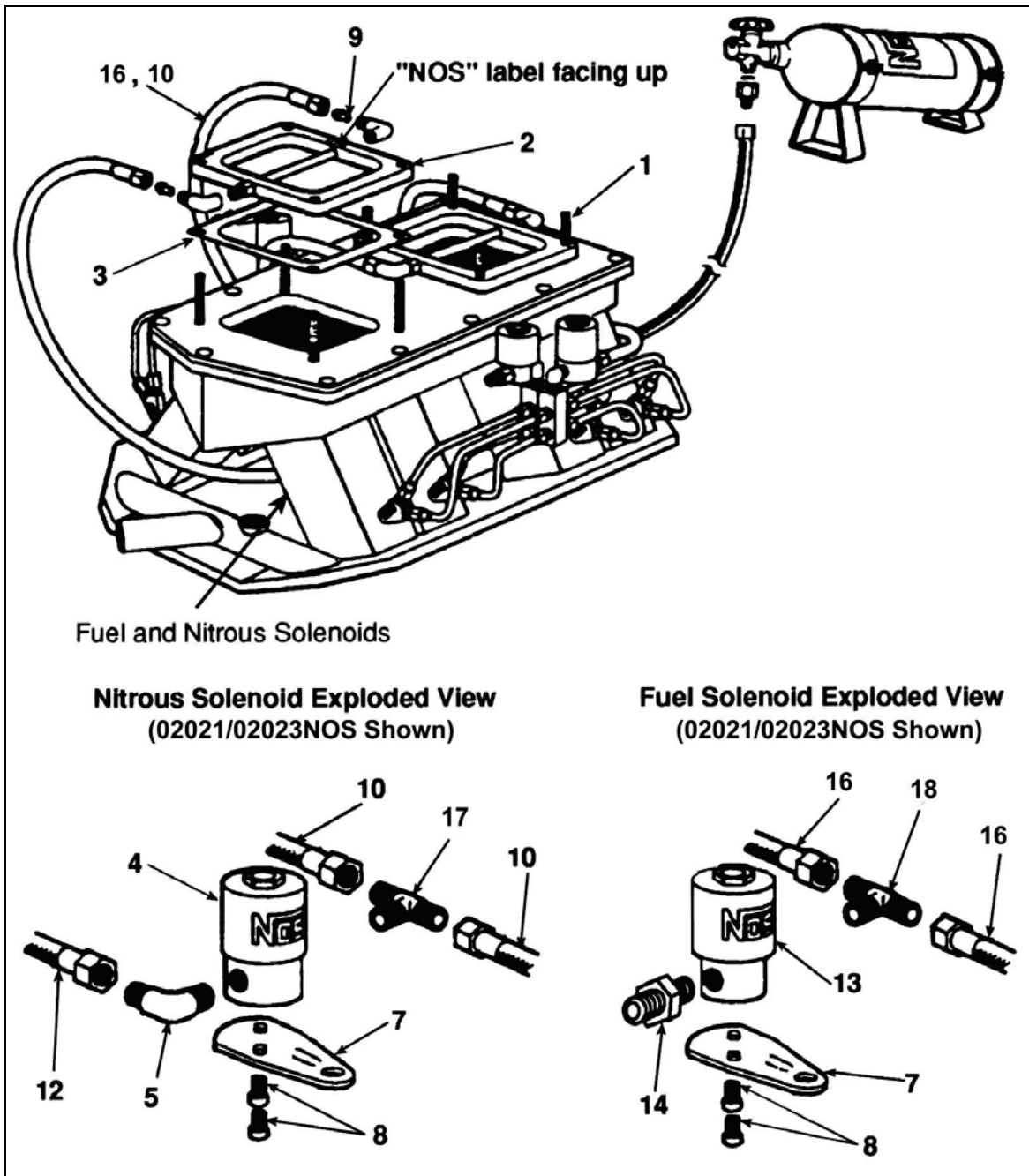

4.1.1.1 Nitrous Solenoid Installation

CAUTION: Do not overtighten the vise in the following procedure or the solenoid will be damaged.

1. Clamp the nitrous solenoid (4) in a bench vise.
2. Install the nitrous filter fitting (5) into the inlet port of the nitrous solenoid.
3. Install the 1/8" NPT x 4AN fitting adapter (6) in the outlet port of the nitrous solenoid.
4. Attach the solenoid mounting bracket (7) to the nitrous solenoid.
5. Loosely mount the nitrous solenoid near the base of the carburetor on the nitrous (blue) end of the injector plate.
6. Install the proper jet (9) in the injector plate (See Table 4), with the beveled edge out.
7. Connect the outlet port of the nitrous solenoid to the injector plate using the blue 4AN x 3AN braided steel line (10).
8. Tighten the solenoid mount.
9. Connect the nitrous solenoid inlet port to the 6AN cross fitting (11) using the 4AN x 6AN hose (12).

4.1.1.2 Fuel Solenoid Installation

CAUTION: Do not overtighten the vise in the following procedure or the solenoid will be damaged.

1. Clamp the fuel solenoid (13) in a bench vise.
2. Install the red 1/8" NPT x 6AN fitting (14) into the inlet port of the fuel solenoid.
3. Install the 1/8" NPT x 4AN fitting adapter (15) in the outlet port of the fuel solenoid.
4. Attach the solenoid mounting bracket (7) to the fuel solenoid.
5. Loosely mount the fuel solenoid near the base of the carburetor on the fuel (red) end of the injector plate.
6. Install the proper jet (9) in the injector plate (See Table 4), with the beveled edge out.
7. Connect the outlet port of the fuel solenoid to the injector plate using the red 4AN x 3AN braided steel line (16).
8. Tighten the solenoid mount.

4.1.2 Solenoid Mounting (Kit Numbers 02021NOS and 02023NOS)

Use the following procedures to install the nitrous solenoid and fuel solenoid.

4.1.2.1 Nitrous Solenoid Installation

CAUTION: Do not overtighten the vise in the following procedure or the solenoid will be damaged.

1. Clamp the nitrous solenoid (4) in a bench vise.
2. Install the nitrous filter fitting (5) into the inlet port of the nitrous solenoid.
3. Install the blue 1/8" NPT x 4AN TEE (17) in the outlet port of the nitrous solenoid.
4. Install the proper jet (9) in the injector plate (See Table 4), with the beveled edge out.
5. Connect the outlet ports of the nitrous solenoid TEE to the injector plate using the blue 4AN x 3AN braided steel line (10).

4.1.2.2 Fuel Solenoid Installation

CAUTION: Do not overtighten the vise in the following procedure or the solenoid will be damaged.

1. Clamp the fuel solenoid (13) in a bench vise.
2. Install the red 1/8" NPT x 6AN fitting (14) into the inlet port of the fuel solenoid.

3. Install the 1/8" NPT x 4AN TEE (18) in the outlet port of the fuel solenoid.
4. Install the proper jet (9) in the injector plate (See Table 4), with the beveled edge out.
5. Connect the outlet ports of the fuel solenoid TEE to the injector plate using the red 4AN x 3AN braided steel line (16).

4.2 Electrical System Installation

NOTE: If you do not already have a electrical pack kit, it is available as NOS part # 15634NOS (Single Stage) 15635NOS (Dual Stage).

Refer to Figure 14 and procedures in this section for electrical system installation.

WARNING! Death or injury may occur from working on a charged electrical system.

1. Disconnect the car battery at the ground cable (if not already done).
2. Install the activation pushbutton (19) in the vehicle's interior within easy reach of the driver.
3. Install the wiring relay (20) in the engine compartment near the battery. The relay's orange wire should reach the battery (+) terminal.
4. Connect the orange relay wire to the battery (+) terminal.
5. Connect one wire from each solenoid together. Join the solenoid wires to the blue relay wire.
6. Connect the green relay wire to either terminal on the pushbutton. Ground the other terminal on the pushbutton.
7. Connect the red relay wire to the microswitch at the post not connected to the arming switch (See Figure 14).
8. Reconnect the battery.
9. Temporarily ground the open lead of the nitrous solenoid.
10. Turn the arming switch ON.
11. Hold the throttle wide open.
12. Depress the activation pushbutton. You should hear a clicking noise if the nitrous solenoid is cycling correctly. If no noise is heard, check all the wiring connections and the wiring schematic.
13. Disconnect the temporary solenoid ground.
14. Temporarily ground the open lead of the fuel solenoid.
15. Turn the arming switch ON.
16. Depress the activation pushbutton. You should hear a clicking noise if the fuel solenoid is cycling correctly. If no noise is heard, check all the connections and the wiring schematic.
17. Connect the remaining wire from each solenoid to the ground.

Chapter 5 Baseline Tuning Suggestions

The Direct Port Injection part of your NOS kit comes standard with 3 levels of jetting. The Injector Plate part of your NOS kit comes standard with 6 levels of jetting. These jetting combinations are conservative. They are calibrated to operate with 900 psi nitrous oxide bottle pressure and 6 psi of flowing fuel pressure.

Using these jetting combinations with lower bottle pressures and/or higher fuel pressure may produce an excessively rich condition. This can result in a loss of power, excessive exhaust smoke (black), or misfiring (backfiring through the exhaust). This condition may also arise if your carburetor is jetted excessively rich.

If you experience any of these conditions, or you desire to maximize the power output from your system, refer to Chapter 7, "Advanced Tuning Suggestions".

CAUTION: Use of excessive bottle pressure and/or inadequate fuel pressure can result in an excessively lean condition. In extreme cases, this will produce catastrophic engine failure.

Table 4 Suggested Baseline Tuning Combinations

Configuration	HP	Jetting		Baseline Pressures*		Fuel Quality	Ignition Timing	Spark Plug Heat Range (NGK or Equiv))
		N ₂ O	Fuel	N ₂ O	Fuel			
Fogger Jetting	150	22	18	950	6PSI	100+ Octane	***	-8
	175	24	20	950	6PSI	110+ Octane	***	-9
	250**	28	24	950	6PSI	112+ Octane	***	-10
	300**	32	28	950	6PSI	114+ Octane	***	-10
	350**	36	32	950	6PSI	114+ Octane	***	-11
	400	40	36	950	6PSI	116+ Octane	***	-11
	500	42	38	950	6PSI	116+ Octane	***	-11
Upgrade Cheater Plate Jetting (Single Plate)	100**	47	47	950	6PSI	If adding this kit to a Fogger kit, add the 2 HP levels together and use the Octane rating to the right of the HP as shown above in the Fogger jetting section	***	If adding this kit to a Fogger kit, add the 2 HP levels together and use the Plug Heat Range to the right of the HP as shown above in the Fogger jetting section
	125**	55	55	950	6PSI		***	
	150**	63	63	950	6PSI		***	
	175**	73	73	950	6PSI		***	
	200**	82	82	950	6PSI		***	
	250**	93	93	950	6PSI		***	
Upgrade Cheater Plate Jetting (Dual Plate)	100**	33	33	950	6PSI		***	
	125**	38	38	950	6PSI		***	
	150**	52	52	950	6PSI		***	
	175**	59	59	950	6PSI		***	
	200**	65	65	950	6PSI		***	
	250**	73	73	950	6PSI		***	

* **Baseline Pressures are set as follows:** Fuel is set as a flowing pressure through a .073 jet for the Fogger kits and the actual jet used on the Cheater plates.

** **Jetting included in Kits**

*** **See section 7.1.B for timing recommendations**

Chapter 6 Preparing for Operation

After you have completed the installation of your NOS Fogger system kit, perform the following checkout procedure before operating your vehicle.

NOTE: Before performing steps 1-4, make sure that the nitrous bottle valve is closed and the main nitrous supply line is empty.

1. Turn on the fuel pump.
2. Check all the fuel lines and fittings for leaks.
3. Start the engine.
4. Turn the arming switch on. Set the engine speed at 2000 RPM. Briefly depress the activation arm on the microswitch. Engine speed should decrease if the fuel delivery system is performing properly; if not, refer to Appendix A, Troubleshooting Guide.
5. Open the nitrous bottle valve.

NOTE: There should be no change in the engine idle speed. If the idle speed changes, refer to Appendix A, Troubleshooting Guide.

6. Inspect the nitrous lines and fittings for leaks.
7. ENJOY!

Chapter 7 Advanced Tuning for Maximum Power

After performing the Baseline Tuning Suggestion—Chapter 3, if you desire to maximize the performance of your system, perform the following:

NOTE: Always perform the nitrous/fuel ratio modifications listed in Section 7.1.A before attempting to optimize the ignition timing (Section 7.1.B). Improper nitrous/fuel ratio combinations can mislead you when attempting to optimize the ignition timing.

7.1. A Determining Optimum Nitrous/Fuel Ratio

The jetting combinations included in your kit are compromises, intended to provide you with a safe starting point. They are intended to be used with 900 psi nitrous bottle pressure and 6 psi flowing fuel pressure. In many instances, installing slightly smaller fuel jets than the units provided in your kit, will provide a more optimum nitrous/fuel ratio and increase power.

Always run the baseline jetting included in your kit before attempting to decrease fuel jet size. Optimum jetting can be determined using the following scheme.

1. Stabilize the nitrous bottle pressure at 900 psi.
2. Perform a dynamometer pull or a full throttle pass down the racetrack. Note the power reading or vehicle mph (not e.t.). Examine the spark plugs for an indication of lean or rich nitrous/fuel conditions (refer to Figure 16 for tips on reading the spark plugs).
 - 2A. If spark plugs appear to be excessively rich, decrease the fuel jet size 2 steps (ex. 32 to 30, 36 to 34, etc.).
 - 2B. If spark plugs appear to be excessively lean, increase the fuel jet size 2 steps.
 - 2C. If spark plugs have a “like new” appearance on the porcelain and electrode, do not make a fuel jetting change.
3. Repeat steps 1 and 2 until the desired mixture is obtained.

Figure 15 Spark Plug Condition

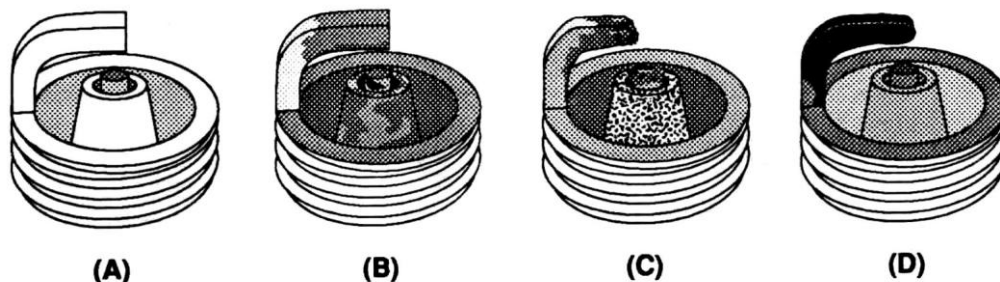

How to Read Spark Plugs from a Nitrous Oxide Injected Engine

A. Correct Timing, Mixture, and Spark Plug Heat Range

The ground strap retains a “like new” appearance. The edges are crisp, with no signs of discoloration. The porcelain retains a clear white appearance with no “peppering” or spotting.

B. Excessively Rich Mixture

The porcelain may be fuel stained, appearing brown or black. In extreme cases, the ground strap, electrode, and porcelain may be damp with gasoline, or smell of fuel.

C. Detonation

The edges of the ground strap may become rounded. The porcelain has the appearance of being sprinkled with pepper, or may have aluminum speckles. During heavy detonation, the ground strap tip may burn off. This phenomena can result from excessive ignition timing, too high a heat range spark plug, or inadequate fuel octane.

D. Excessively Lean Mixture

The edges of the ground strap may become rounded. Under moderate overheating, the tip of the ground strap can discolor, usually turning purple, or the entire ground strap can become discolored.

7.1. B Determining Optimum Ignition Timing

Determining the correct ignition timing for an engine using nitrous oxide is not cut and dry as it is dependent on many variables. Variables such as piston design, combustion chamber size and design, valve angle, fuel type, nitrous system design, and other factors

all play a critical role as to what timing a specific engine/vehicle combination needs. When running larger amounts of nitrous, it is critical that the proper ignition timing be run as well as the proper spark plug heat range.

There is one specific timing that is most ideal for a specific engine and nitrous tune-up. In the end the best and correct method to determine timing in a car is to read the spark plugs.

Due to all these variables, it is difficult to recommend a generic timing for a given amount of nitrous. However the information below is intended to provide a starting point. After this, it is best to use the spark plugs as an indicator as to what timing a specific engine requires. The spark plugs also will help with nitrous and fuel jetting as well as fuel pressure needs.

One large variable that drives the ideal ignition timing is the "combustion efficiency". This is a combination of the cylinder head valve angle, combustion chamber size and burn characteristics, and piston dome design among other things. The more efficient the overall combustion efficiency is, the less timing is needed with nitrous. Note that when running large amount of nitrous, the old school rule of "take out two degrees per 50 HP of nitrous" is not ideal or wise.

The following timing recommendations below are based on nitrous HP amounts and a factor called "Combustion Efficiency". Combustion Efficiency takes into account the piston dome, chamber size, valve angle, and other factors. It is split up into three categories, "High", "Medium", and "Low". The following reviews these:

"High" – An engine with an exceptionally efficient and quick burn rate when running nitrous. Typically this would have a piston with a dish, flattop, or very small, flat dome design. Combustion chambers are small and valve angles are greatly reduced from the "factory" valve angle. Generic examples are engines with current high end race heads that have valve angles reduced 7-11 from stock, very small combustion chambers, and flat top piston that still maintain 13-14:1 compression ratios.

"Medium" – An engine with a small and efficient chamber. An example could be a SBC with an 18 degree head with a moderate piston dome.

"Low" – Older engines with factory valve angles. Pistons may have large domes to maintain high compression ratios. Large, open combustion chambers. An example would be a BBC engine with a 119cc open chamber and large dome piston.

The following are some initial recommendations for timing. Be conservative and read your plugs. Run an 1/8th mile hit rather than a 1/4 mile pass to start to see initial plug strap readings. The "High" recommendation is based on NGK heat ranges. An equivalent Autolite or other brand can be used.

Note: These are for V8's. For a 4 cylinder, cut these numbers in half.

Table 5 Suggested Baseline Timing Combinations

Nitrous HP	Combustion Efficiency	Timing	NGK Spark Plug or Equiv.	Fuel/Octane
100	Low	32	Stock	93+
100	Medium	30	Stock	93+
100	High	28	Stock	93+
125	Low	31	Stock/-7	100+
125	Medium	29	Stock/-7	100+
125	High	27	Stock/-7	100+
150	Low	29	-8	100+
150	Medium	27	-8	100+
150	High	25	-8	100+
175	Low	27	-9	110+
175	Medium	25	-9	110+
175	High	23	-9	110+
200	Low	24	-9	110+
200	Medium	22	-9	110+
200	High	20	-9	110+
250	Low	22	-10	112+
250	Medium	29	-10	112+
250	High	18	-10	112+
300	Low	20	-11	114+
300	Medium	18	-11	114+
300	High	16	-11	114+
350	Low	18	-11	114+
350	Medium	16	-11	114+
350	High	14	-11	114+
400	Low	16	-11	116+
400	Medium	14	-11	116+
400	High	12	-11	116+
500	Low	12	-11	116+
500	Medium	10	-11	116+
500	High	8	-11	116+
600	Low	8	-11	116+
600	Medium	6	-11	116+
600	High	2	-11	116+

Chapter 8 Routine Maintenance

8.1 Nitrous Solenoid Filter

When nitrous bottles are refilled, they can become contaminated with debris, if the refiller does not have an adequate filter in his transfer pump mechanism. Contaminants in the bottle will eventually become lodged in the nitrous solenoid filter fitting.

You should periodically (after every 20-30 pounds of nitrous usage) examine the mesh in the nitrous filter for debris.

To clean the filter, follow the following steps:

1. Close the valve on the nitrous bottle.
2. Empty the main nitrous feed line.
3. Disconnect the main nitrous feed line from the nitrous solenoid.
4. Remove the nitrous filter fitting from the nitrous solenoid.
5. Remove **all** Teflon paste debris from the solenoid inlet port threads and from the nitrous solenoid filter pipe threads.
6. Examine the mesh in the nitrous filter fitting for contaminants. Blow out debris with compressed air, if necessary.
7. Apply fresh Teflon paste to the nitrous filter pipe threads. Reinstall the filter in the nitrous solenoid.
8. Reconnect the main nitrous supply line to the nitrous solenoid.

8.2 Nitrous Solenoid Plunger

8.2. A General Information

The seals used in NOS nitrous solenoid plungers are constructed from materials, which are designed to be used with nitrous oxide. When kept free from fuel contaminants or from overpressurization, they should provide trouble free performance.

You should periodically (after every 20-30 pounds of nitrous usage) examine the seal in the nitrous solenoid plunger.

Due to the Pro Fogger System being a wet manifold style nitrous kit, the nitrous solenoid plunger will get exposed to fuel vapors. This is unavoidable. Fluctuations in the intake manifold pressure due to opening and closing of the throttle induce flow into and out of the NOS injector plate spray bars (nitrous and fuel), when the NOS system is not in use. Long term exposure of the nitrous solenoid plunger seal to the fuel vapors will result in swelling of the plunger seal. This will reduce the nitrous flow (causing an excessively rich nitrous/fuel condition and a loss of power).

The seals used in NOS nitrous solenoid plungers are designed to work at pressures up to 1100 psi. Exposing the plunger to excessive pressure (whether the vehicle is sitting or in-use) can result in the seal in the plunger swelling or in extreme cases disintegrating.

NOTE: The seals are designed so that if they fail due to overpressurization, they will not leak, the valve will just fail to flow nitrous oxide.

Swelling of the nitrous solenoid plunger seal will reduce nitrous flow (causing an excessively rich nitrous/fuel condition and a loss of power).

8.2. B Nitrous Solenoid Plunger Disassembly and Inspection

1. Close the valve on the nitrous bottle.
2. Empty the main nitrous supply line.
3. Remove the retaining nut from the nitrous solenoid.
4. Remove the coil and housing from the nitrous solenoid base.
5. Unscrew the stem from the nitrous solenoid base. Do this by double nutting the stem, or by using a solenoid stem removal tool (NOS P/N 16666-SNOS). **Do not use pliers on the solenoid stem. Damage to the stem will result.**
6. Remove the stem, spring, and plunger from the solenoid base.

7. Examine the plunger seal for swelling. The seal surface should be flat, except for a small circular indentation in the center of the seal;

A fuel-contaminated seal will protrude from the plunger and be dome-shaped. A fuel-contaminated seal may return to its original shape if left out in the fresh air for several days. It may then be returned to service.

A seal, which has been overpressurized, may be dome-shaped, or the sealing surface may be flat with the seal protruding out of the plunger. A dome-shaped seal may return to its original shape if left out in the fresh air for several days. It may then be returned to service. A seal, which is flat, but protrudes from the plunger body has probably failed internally and should be replaced.

Figure 16 Exploded View of a Typical Solenoid

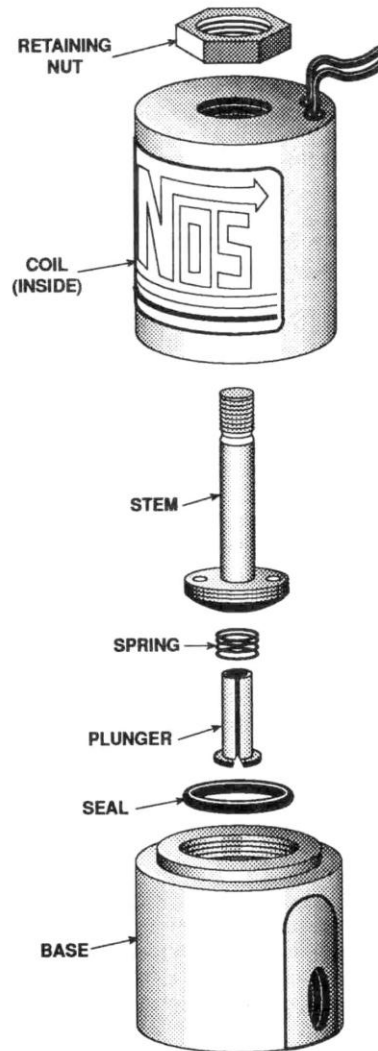

Appendix A Troubleshooting Guide

The troubleshooting chart on the following pages should help determine and rectify most problems with your installed NOS system. If you still need assistance determining or fixing problems, call NOS Technical Support Department at 1-866-GOHOLLEY or fax at 1-270-781-9772.

PROBLEM	POSSIBLE CAUSES	DIAGNOSTIC PROCEDURE	CORRECTIVE ACTION
No change in engine speed when the fuel solenoid is activated (Preparing for Operation—Chapter 6).	System wired incorrectly.	Compare wiring to schematic.	Wire per instructions.
	Restricted fuel line.	Inspect fuel line for restrictions (crimped or plugged).	Remove restrictions.
	Malfunctioning fuel solenoid.	Turn arming switch ON. Activate microswitch. Solenoid should make “ticking” noise.	Repair/replace solenoid.

Change in engine speed when nitrous bottle valve is opened (Preparing for Operation—Chapter 6).	Malfunctioning nitrous solenoid.	Remove and inspect solenoid.	Repair/replace solenoid.
Engine runs rich when system is activated.	Bottle valve not fully opened.	Check bottle valve.	Open valve fully.
	Bottle mounted improperly.	Check bottle orientation.	Mount bottle properly.
	Plugged nitrous filter.	Inspect filter.	Clean/replace filter.
	Low bottle pressure.	Check bottle temperature.	Set bottle temperature to 80° to 85°F.
	Inadequate nitrous supply.	Weigh bottle.	Fill bottle. 1-800-99-REFILL
	Mismatched N ₂ O/fuel jetting.	Compare jetting to recommended values.	Install correct jets.
	Excessive fuel pressure.	Install fuel pressure gauge, such as NOS P/N 15931NOS, in the fuel line. Measure the pressure during acceleration, with the system activated.	Regulate pressure down, or install smaller fuel jetting.
	Loose nitrous solenoid wiring.	Inspect the solenoid wiring.	Repair wiring.
Malfunctioning nitrous solenoid.	WARNING: <i>Solenoid discharges nitrous at a high rate. Don't inhale nitrous; death may occur. Skin contact may cause frostbite.</i> Close bottle valve. Disconnect the solenoid outlet port. Disconnect the solenoid (+) lead. Open the nitrous bottle valve. Briefly connect the +12V to the solenoid. Solenoid should discharge N ₂ O at a high rate.	Rebuild solenoid.	
No change in performance when system is activated.	System wired incorrectly.	Compare nitrous wiring to schematic.	Wire system per instructions.
	Loose ground wire(s).	Connect 12V test light to battery (+) terminal. Check for continuity at grounds noted in schematic.	Tighten/repair loose ground(s).
	Malfunctioning pushbutton.	Turn bottle valve off. Turn arming switch on. Connect 12V test light to battery (-). Turn pushbutton switch ON. Check for continuity at pushbutton output pole.	Replace pushbutton.
	No power to arming switch.	With vehicle ignition on, connect 12V test light to battery (-) terminal. Check for power at pole #1 on arming switch.	Repair wiring.
	Malfunctioning arming switch.	With vehicle ignition on, turn arming switch ON. Connect 12V test light to battery (-) terminal. Check for power at red wire on arming switch.	Replace arming switch.
	Malfunctioning throttle microswitch.	Temporarily disconnect power relay green wire from microswitch. Connect 12V test light to battery (+) terminal. Manually set microswitch ON. Check for continuity at microswitch positive terminal (see wiring schematic).	Replace throttle microswitch.
	Overly rich fuel condition.	Check for black smoke or backfiring through exhaust with system activated.	Install smaller fuel jet or decrease fuel pressure.
Engine detonates mildly when system is activated.	Excessive ignition timing.	Check ignition timing.	Reduce timing in 2° increments, up to 8° from non-nitrous conditions.
	Inadequate octane fuel.		Use higher octane fuel; up to 116VPC-16.
	Spark plug heat range too high.		Reduce spark plug heat range (maximum 2 steps).
	Too much nitrous flow.		Reduce nitrous jetting.
Engine detonates heavily when system is activated.	Inadequate fuel delivery due to: Plugged fuel filter.	Inspect fuel filter.	Clean or replace filter.
	Crimped fuel line.	Inspect fuel line.	Replace crimped line.

	Weak fuel pump.	Install fuel pressure gauge, such as NOS P/N 15931NOS. Run engine under load at wide-open throttle, with system activated.	Repair/replace fuel pump.
High rpm misfire when system is activated.	Excessive spark plug gap.	Inspect spark plugs.	Set spark plug gap at 0.030" to 0.035".
	Weak ignition/ignition component failure.	Inspect components (plug wires, distributor cap, etc.)	Replace worn components.
Surges under acceleration when system is activated.	Inadequate supply of nitrous.	Check bottle weight.	Replace with full bottle.
	Bottle mounted incorrectly.	Compare bottle position and orientation to instructions.	Mount or orient bottle correctly.

Nitrous Oxide Accessories

To maintain optimum system performance on cold days, a **Bottle Heater (P/N 14164NOS)** is a must.

To maximize the efficiency of the system, a **Bottle Blanket (P/N 14165NOS)** is also suggested.

#10 Bottle Heater P/N 14164NOS



#10 Bottle Blanket P/N 14165NOS



2 Stage WOT/RPM-Activated Switch P/N 15982NOS



Remote Bottle Valve P/N 16058NOS



The **Stage WOT/RPM-Activated Switch P/N 15982NOS**, allows hands-free nitrous operation and prevents nitrous from being injected at speeds above or below operator-set levels. Greatly reduces chance of accidental engine damage. ON/OFF levels adjust from 0 to 9999 RPM.

The **Remote Bottle Valve, P/N 16058NOS** is the perfect convenience accessory—electronically turns nitrous bottle on and off with the flick of a switch—no more trips to the trunk. It is also great as a safety shut-off valve. It operates on 12V DC. The complete kit includes hardware and installation instructions.

The **Nitrous Pressure Gauge, P/N 15910NOS (-4AN lines) or P/N 15912NOS (-6AN lines)** [0-1500 PSIG] is designed to provide accurate ($\pm 2\%$ of full scale) readings of fuel pressure in carbureted applications.

The **Fuel Pressure Gauge, P/N 15900NOS** [0-15 PSIG] is engineered to provide accurate ($\pm 2\%$ of full scale) readings of fuel pressure in carbureted applications.

NOS Technical Support
Toll-Free Phone: 1-866-GOHOLLEY
Phone: 1-270-781-9741
Fax: 1-270-781-9772

For online help, please refer to the Tech Service section of our website: www.holley.com