

MSD IGNITION™ INSTALLATION INSTRUCTIONS

MSD Module Selectors Two Step, PN 8739 Three Step, PN 8737

Parts Included:

1 - Module Selector
4 - Mounting Screws

1 - Parts Bag, Wiring Terminals

Note: Do NOT use solid core spark plug wires with any MSD component.

The MSD Module Selectors provide the ability to switch between two or three different rpm or degree modules. The different modules are activated when 12 volts are applied to the corresponding activation wire. The Selectors work with either a Soft Touch Rev Control or any MSD Timing Control that uses plug-in modules.

- The 2-Step Module Selector switches between two modules.
- The 3-Step Module Selector switches between three modules.

ACTIVATION WIRES	
Module 2	This is the default module. It is active when no voltage is present on the other wires.
Module 1	Active when 12 volts are applied to the Red Wire.
Module 3	Active when 12 volts are applied to the Blue Wire. (3-Step Only)
Note: If 12 volts are applied to the Red and Blue wires at the same time, Module 3 will be active.	

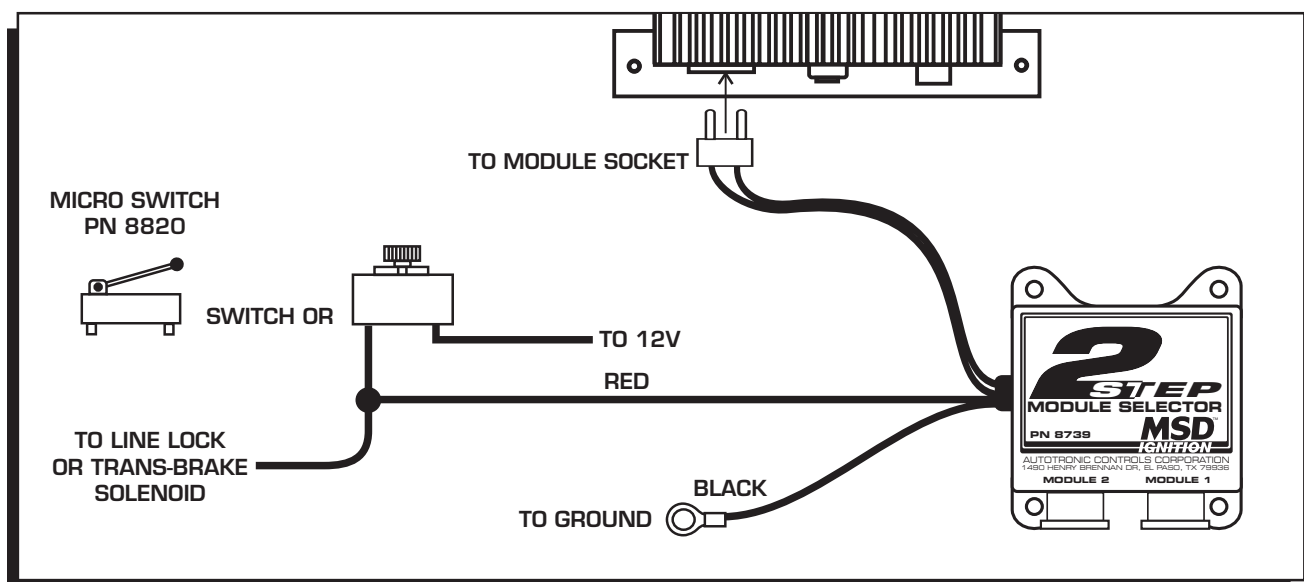

Figure 1 Basic Two Step Module Selector Installation.

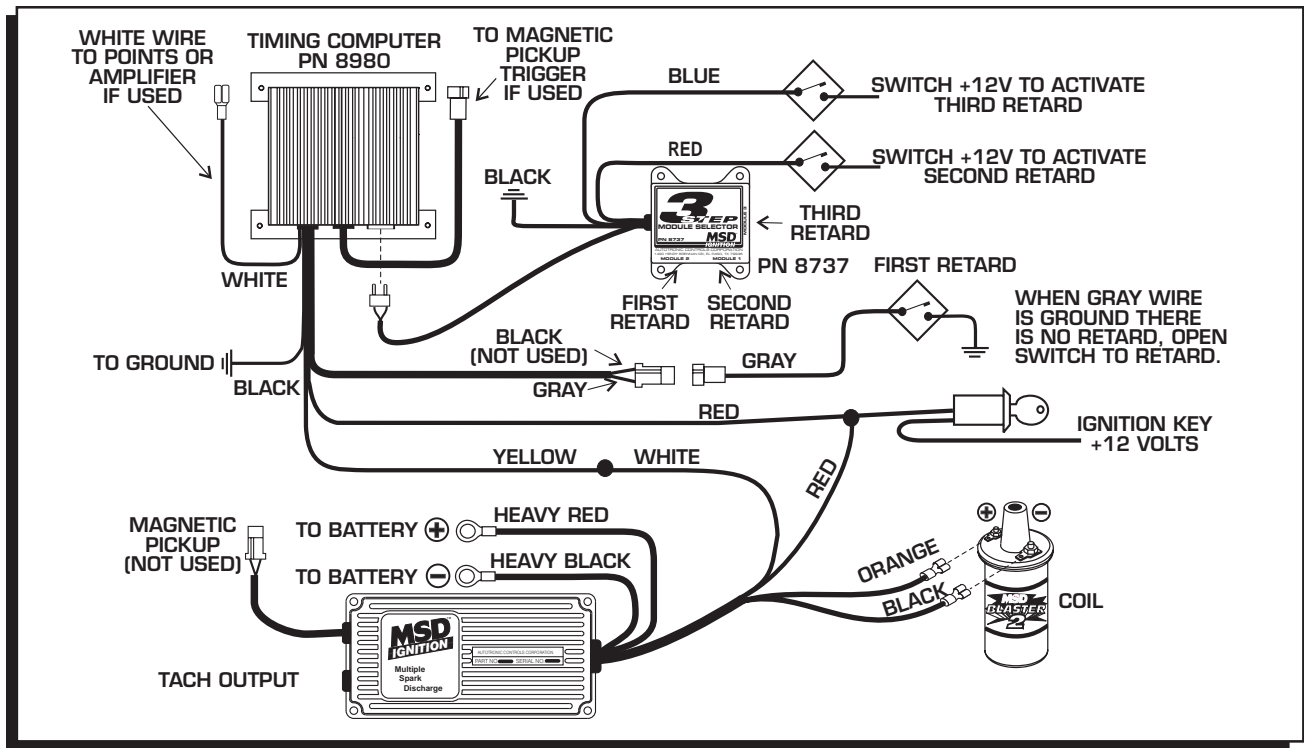

Figure 4 Wiring a Three Step to a Timing Control for Multiple Retards.

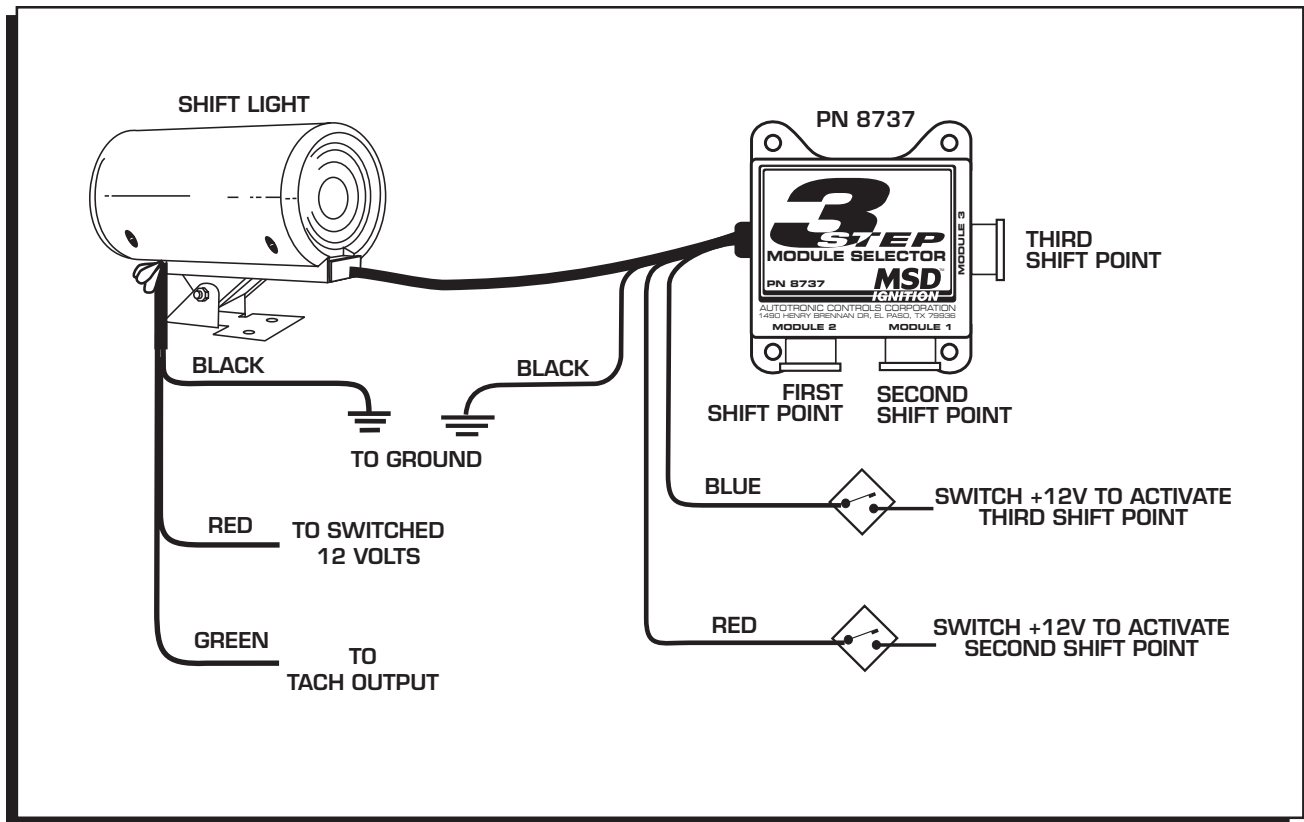

Figure 5 Wiring a Three Step to a Shift Light for Multiple Shift Points.



INSTALLATION INSTRUCTIONS

TECH NOTES

Service

In case of malfunction, this MSD component will be repaired free of charge according to the terms of the warranty. When returning MSD components for service, Proof of Purchase must be supplied for warranty verification. After the warranty period has expired, repair service is charged based on a minimum and maximum charge.

Send the unit prepaid with proof of purchase to the attention of: **Customer Service Department, Autotronic Controls Corporation, 12120 Esther Lama, Suite 114, El Paso, Texas 79936.**

When returning the unit for repair, leave all wires at the length in which you have them installed. Be sure to include a detailed account of any problems experienced, and what components and accessories are installed on the vehicle.

The repaired unit will be returned as soon as possible after receipt, COD for any charges. (Ground shipping is covered by warranty). All units are returned regular UPS unless otherwise noted. For more information, call the MSD Customer Service Line (915) 855-7123. MSD technicians are available from 8:00 a.m. to 5:00 p.m. Monday - Friday (Mountain Time).

Limited Warranty

Autotronic Controls Corporation warrants MSD Ignition products to be free from defects in material and workmanship under normal use and if properly installed for a period of one year from date of purchase. If found to be defective as mentioned above, it will be replaced or repaired if returned prepaid along with proof of date of purchase. This shall constitute the sole remedy of the purchaser and the sole liability of Autotronic Controls Corporation. To the extent permitted by law, the foregoing is exclusive and in lieu of all other warranties or representations whether expressed or implied, including any implied warranty of merchantability or fitness. In no event shall Autotronic Controls Corporation be liable for special or consequential damages.