

MSD INSTALLATION INSTRUCTIONS

MSD Distributor Cap PN 8433 and PN 84333

ONLINE PRODUCT REGISTRATION: Register your MSD product online. Registering your product will help if there is ever a warranty issue with your product and helps the MSD R&D team create new products that you ask for! Go to www.msperformance.com/registration.

Parts Included:

1 - Cap
2 - 10-32 x 1.25" Hex Screws

1 - Wire Retainer
2 - 1.5" Phillips Head Screws

Note: If you need to adapt your spark plug wire boots and terminals to fit the towers of the PN 8433 Cap, MSD offers a kit of nine boots and terminals, PN 8849.

The PN 8433 Cap fits all of the MSD Distributors that use the GM Socket style cap (MSD PN 8437). It will also fit GM Distributors that use a "window" style cap.

Before installing the new cap, note the location of the spark plug wires. It is a good idea to mark the location of one wire before removing it while leaving the other wires connected to the old cap. Then, with the new cap installed, you can install each wire individually avoiding any confusion.

After installing the spark plug wires, position the retainer over the boots. Align the mounting bosses and use the supplied 1.5" self-tapping Phillips head screws to hold the retainer in place. It may be necessary to apply a slight amount of lubricant to the boots to help them seat into the retainer properly.

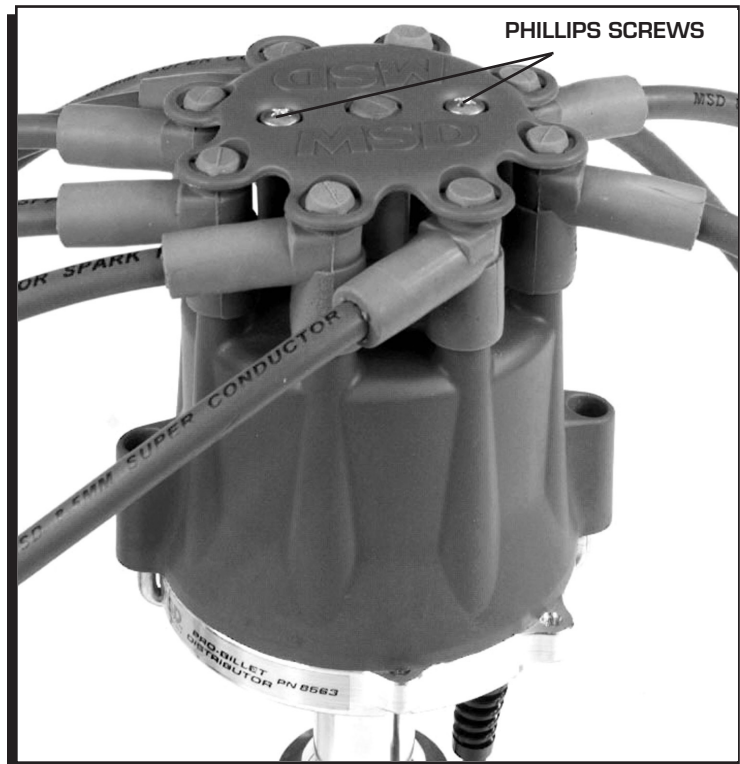

Figure 1 Installing the Wire Retainer.

MSD INSTALLATION INSTRUCTIONS

Installation Option: This Cap can also be bolted down to an MSD Pro-Billet or Billet Distributor base with the supplied hardware. To accomplish this, the spring clips must be cut off (Figure 2).

Note: When the cap is bolted down, the location of the spark plug wires must be changed.

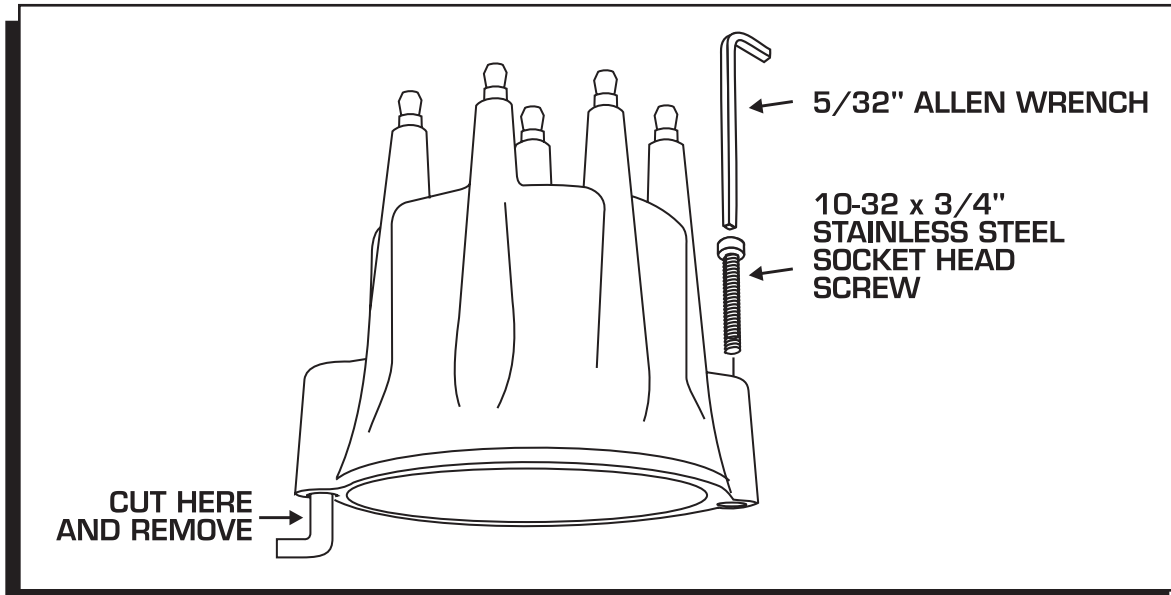

Figure 2 Optional Installation by Bolting the Cap Down.

Service

In case of malfunction, this MSD component will be repaired free of charge according to the terms of the warranty. When returning MSD components for warranty service, **Proof of Purchase** must be supplied for verification. After the warranty period has expired, repair service is based on a minimum and maximum fee.

All returns must have a Return Material Authorization (RMA) number issued to them before being returned. To obtain an RMA number please contact MSD Customer Service at 1 (888) MSD-7859 or visit our website at www.msdpower.com/rma to automatically obtain a number and shipping information.

When returning the unit for repair, leave all wires at the length in which you have them installed. Be sure to include a detailed account of any problems experienced, and what components and accessories are installed on the vehicle. The repaired unit will be returned as soon as possible using Ground shipping methods (ground shipping is covered by warranty). For more information, call MSD at (915) 855-7123. MSD technicians are available from 7:00 a.m. to 5:00 p.m. Monday - Friday (mountain time).

Limited Warranty

MSD warrants this product to be free from defects in material and workmanship under its intended normal use*, when properly installed and purchased from an authorized MSD dealer, for a period of one year from the date of the original purchase. This warranty is void for any products purchased through auction websites. If found to be defective as mentioned above, it will be repaired or replaced at the option of MSD. Any item that is covered under this warranty will be returned free of charge using Ground shipping methods.

This shall constitute the sole remedy of the purchaser and the sole liability of MSD. To the extent permitted by law, the foregoing is exclusive and in lieu of all other warranties or representation whether expressed or implied, including any implied warranty of merchantability or fitness. In no event shall MSD or its suppliers be liable for special or consequential damages.

*Intended normal use means that this item is being used as was originally intended and for the original application as sold by MSD. Any modifications to this item or if it is used on an application other than what MSD markets the product, the warranty will be void. It is the sole responsibility of the customer to determine that this item will work for the application they are intending. MSD will accept no liability for custom applications.